

- NOTES:
1. INTERPRET DRAWING PER ASME Y14.5M-1994.
 2. IF APPLICABLE, CRITICAL DIMENSIONS LABELED.
 3. ALL HARDWARE IS KITTED PER 3700-0262.
 4. ALL UPHOLSTERY IS KITTED PER 3700-0233.
- EST. GROSS WT. 835 LBS.
 ▲ KNEE PAD ASSY SETUP HEIGHT.

REVISION HISTORY			
REV	DATE	DESCRIPTION	ECO
A	7/14/2008	PRODUCTION RELEASE	100444
B	9/25/2008	HARDWARE EXCHANGED OUT RIVET NUTS MOVED TO THIS LEVEL	100315
C	10/7/2008	REPLACED 4900-0086 WITH 4900-0088	100329
D	12/8/08	CHANGE SETUP HEIGHT, REPLACE 3011-0113 WITH 3211-0230	100406
E	1/22/2009	REPLACE 4900-0086 WITH 4900-0087	100409
F	1/22/2009	CHANGE TO 1" FOOT PLATE AND PAD	100430

ITEM NO.	PART NUMBER	DESCRIPTION	QTY.
14	3311-0049	ASSY. W. STK. 15LB/330LBS. 60 LB CB	1

ITEM NO.	PART NUMBER	DESCRIPTION	QTY.
15	8500-0057	ASSY. UPHOLSTERY, 15 X 12, F-622-C	1
16	4900-UPHX	UPHOLSTERY, TBD	50 LIN. YDS.

ITEM NO.	PART NUMBER	DESCRIPTION	QTY.
17	1600-0001	TUBE, ROUND, 1", RUBBER, BLK	41 N
18	2120-0292	Guide, Bearing, 10", 12-20	2
19	2120-0379	STANDOFF, 2", ALUMINUM	6
20	2120-3347	CLAMP BELT BARREL, 1" X 30, KNURLED	1
21	2120-3866	SPACER, PULLEY COVERS	1
22	2120-3909	SHAFT, KNEE PIVOT, CHIN DIP	1
23	2120-4013	STOP, 1.0 SHAFT	2
24	2120-4014	CAP. BEARING TUBE STOP	2
25	2140-0273	SHEET, BENT, 16 GA X 60, GUARD	2
26	2210-0001	SHROUD, UPPER, PRO	2
27	2210-0004	SHROUD, LOWER, LONG, OUTSIDE, PRO	1
28	2210-0006	SHROUD, LOWER, MINI, INSIDE, IMPACT	1
29	3211-0136	ASSY. WELD, ROM, KNEE PIVOT	1
30	4161-0074	SCREW, #8-18x1-1/2, PHT-AB, PHCS	14
31	4210-0029	PHCS 3/8-16 X 1.00	10
32	4230-0048	BHSCS, 3/8-16 X 1.0, BRIGHT, Z	1
33	4230-0053	BHSCS, 3/8-16 X 1.4, BRIGHT, Z	3
34	4230-0056	BHSCS, 3/8 X 3, BRIGHT, Z	2
35	4230-0057	BHSCS, 3/8 X 2 1/4, BRIGHT, Z	2
36	4230-0059	BHSCS, 3/8-16 X 4 1/4, BRIGHT, Z	1
37	4230-0060	BHSCS, 3/8-16 X 4 1/2, BRIGHT, Z	1
38	4230-0065	BHSCS, 3/8-16 X 3/4, BRIGHT, Z	2
39	4230-0068	BHSCS, 3/8-16 X 3/4, BRIGHT, Z	4
40	4230-0071	BHSCS, 1/2-13 X 3, BRIGHT, Z	4
41	4230-0075	BHSCS, 1/2-13 X 1, BRIGHT, Z	2
42	4230-0080	BHSCS, 5/16-18 X 2 3/4, BRIGHT, Z	4
43	4230-0083	BHSCS, 1/4-20 X 3/4, BRIGHT, Z	2
44	4900-0001	SSS, 10-30 X 18, BLK	8
45	4900-0002	NUT, NYLOC, 5/16-18	1
46	4900-0029	NUT, NYLOC, JAM, 3/8-16 Z	18
47	4900-0044	NUT, WELD, 5/16-18, SLAB BASE	1
48	4900-0046	U-NUT, #8, PANEL, 025-125	14
49	4900-0048	U-NUT, 1/4-20, EDGE, S31, 025-150	2
50	4900-0071	NUT, NYLOC, 1/2-13	4
51	4900-0005	WASHER, 1/2, Z	2
52	4900-0007	WASHER, SAE, 5/16, Z	5
53	4900-0008	WASHER, SAE, 1/2, Z	8
54	4900-0009	WASHER, SAE, 3/8-16, Z	40
55	4900-0005	MACHINE BUSHING, 1", B GAGE	4
56	4900-0001	BELT, MCTROL, SPOOL	99 N
57	4900-0005	CAP. HANDLE, 1", CHROME	4
58	4900-0037	BEARING, FLANGE, 1.008 X 1.00H	1
59	4900-0118	BEARING, ROLLER, 1", 1.16 OPEN	4
60	4900-0129	LINEAR SHAFT, 1" X 60	2
61	4900-0138	CAP. WEIGHT, NO INDICATOR, BLK	2
62	4900-0139	BEARING, 1 ID X 2 OD, NR16 Z	4
63	4900-0167	STOP, 1R X 1.38, F, DAS	4
64	4900-0183	SHOCK, 30 lbs, 9.50C X 5.50S	1
65	4900-0440	PULLEY BELT, A 750, 388, 1 SW, MOLDED	2
66	4900-0448	RIVET, 3/16, 125-250 GRIP, BLK, ALUM	4
67	4900-0522	COVER, SHROUD BRACKET	2
68	4900-0540	BALL STUD, 10 mm X .75" LG, THD	2
69	4900-0576	PULL PIN, 1/2", K-620PR	1
70	3210-0143	PLAC, IMPACT, HORIZ, S630, CHINDIP ASSIST	2
71	3220-0002	LABEL, SAFETY, KEEP HANDS, SMALL	2
72	3220-0004	LABEL, SAFETY, DO NOT ALTER, SMALL	1
73	3220-0005	LABEL, SAFETY, SECURE TO FLOOR	1
74	3230-0008	LOGO, STAR TRAC, IMPACT, TOP SHROUD	2
75	3230-0009	LOGO, IMPACT, LOWER SHROUD	1
76	3230-0038	LABEL, NAME, CHINDIP ASSIST	2
77	3230-0001	SERIAL NUMBER	1
78	4220-0000	SCREW, BHCS, 3/8-16 X 4.25 Z	6
79	4900-0074	Roller Nut, 3/8-16	1
80	4900-0058	CAP, 2.0 X 2.0, BLACK, TEXTURED	8
81	4230-0050	BHSCS, 3/8-16 X 1, BRIGHT, Z	2
82	4900-0008	PIN, PULL OUT, OD .371 X 4	1
83	4900-0008	PIN, SPRING, 1/8 X 3/4	4
84	2120-0157	PLATE, FOOT, PAD, MED, 11" WID x 16"	4
85	2600-0000	PAD, FOOT, RUBBER, MED	4

ITEM NO.	PART NUMBER	DESCRIPTION	QTY.
1	3211-0129	ASSY. WELD, MAIN FRAME, CHIN DIP	1
2	3211-0137	ASSY. WELD, WGT FRAME, CHIN DIP	1
3	3211-0130	ASSY. WELD, CHIN GRIP, LH	1
4	3211-0131	ASSY. WELD, CHIN UP, RH	1
5	3211-0132	ASSY. WELD, ADJUSTABLE GRIP	2
6	3211-0133	ASSY. WELD, KNEE PIVOT, CHIN DIP	1
7	3211-0134	ASSY. WELD, W. STK. CHIN	1
8	3211-0250	ASSY. WELD, W. STK. CHIN	1
9	2161-0025	PULLEY COVER, OUTER	1
10	2161-0028	PULLEY COVER, INNER	1
11	2140-0386	BKT, EXTRA TALL, KICK PLATE, O.S.	2
12	2130-0088	MODIFIED KICK PLATE, CHIN DIP	1
13	4900-PNTX	POWDER COAT, TBD	2.0 LBS.

DOCUMENT STATUS:
RELEASED

MATERIAL: SEE BOM

FINISH: N/A

DESIGNER: N/A

DATE: N/A

UNISEN, INC. DBA
 4410 Myford Road
 Irvine CA 92606

9MS-S6302AXXXXX F

CHIN DIP ASSIST, MS

SCALE: 1/2" = 1'-0" SHEET 1 OF 2

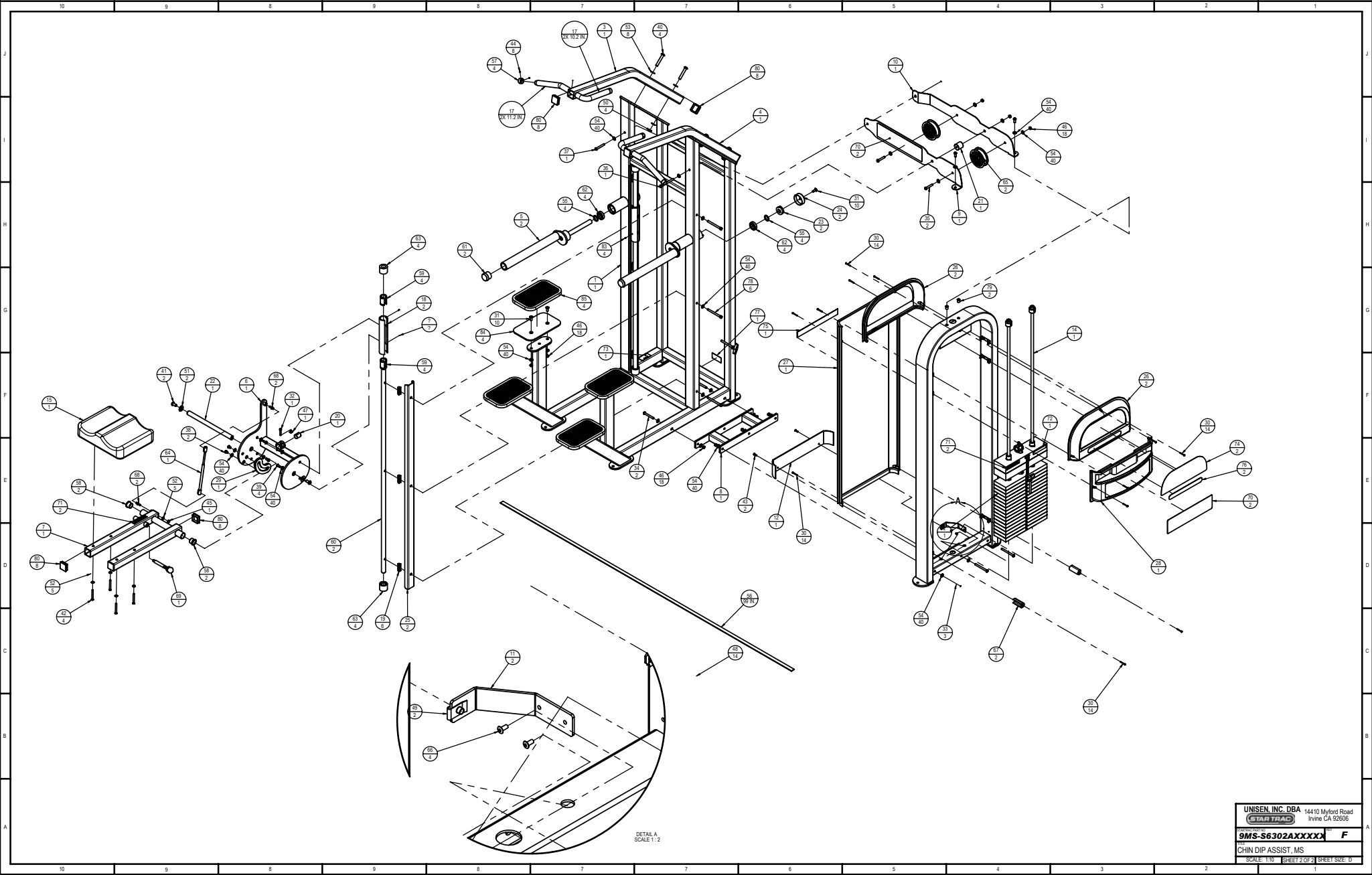

DETAIL A
SCALE 1:2

UNISEN, INC. DBA **STAR TRAC** 14410 Myford Road
Irvine CA 92606

9MS-S6302AXXXX F

CHIN DIP ASSIST, MS

SCALE: 1/16 SHEET 2 OF 2 SHEET SIZE: D