

REVISIONS			
REV.	DATE	DESCRIPTION	ECO
A	11/11/2009	PRODUCTION RELEASE	100596

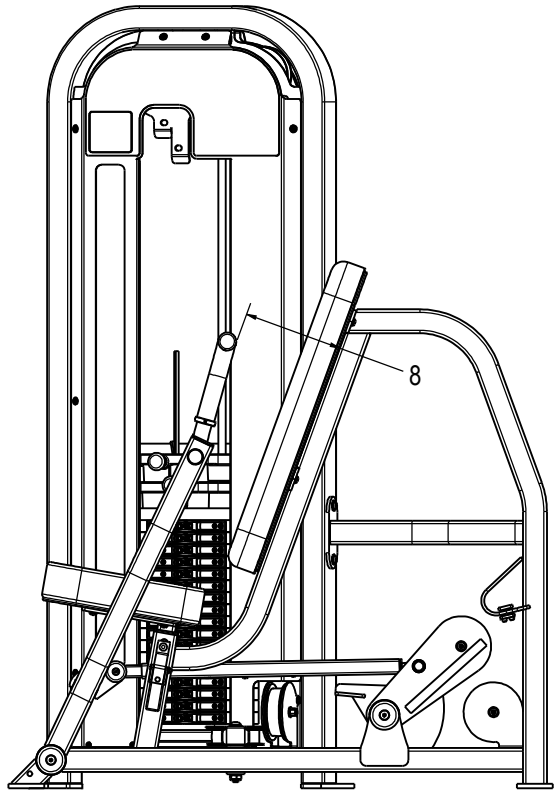
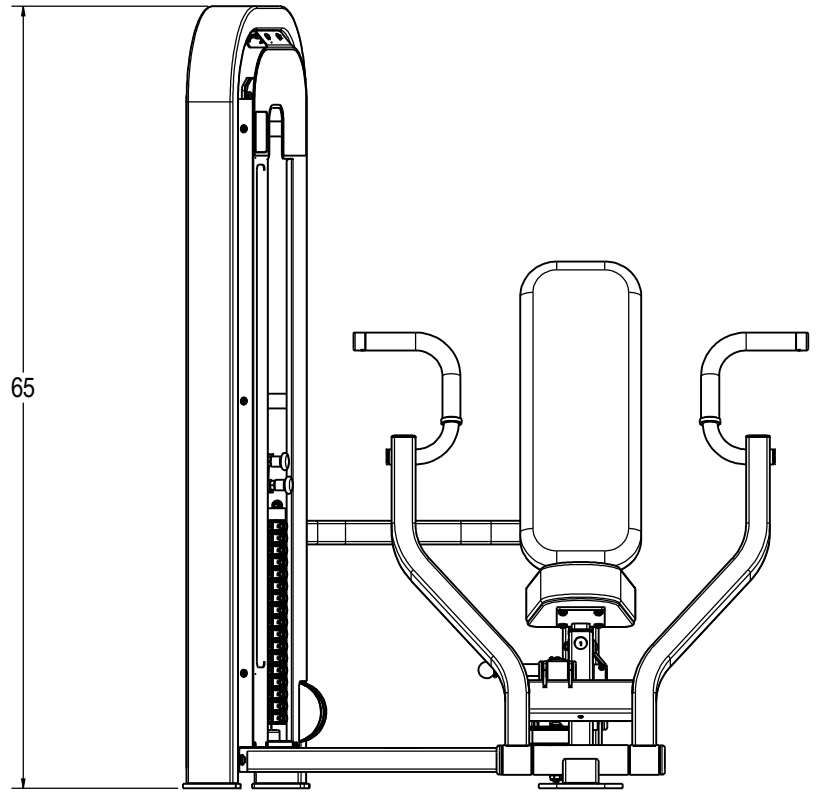
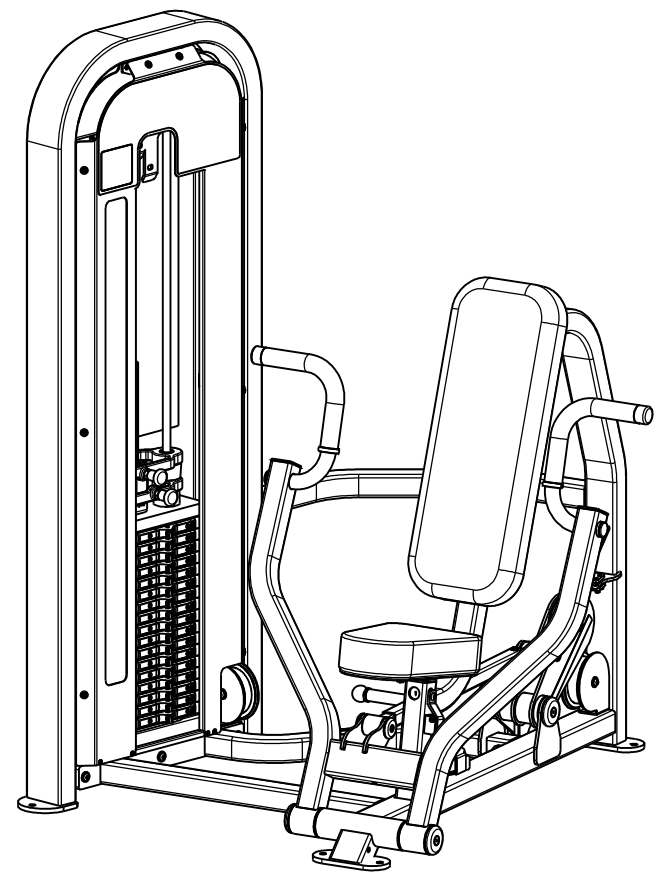
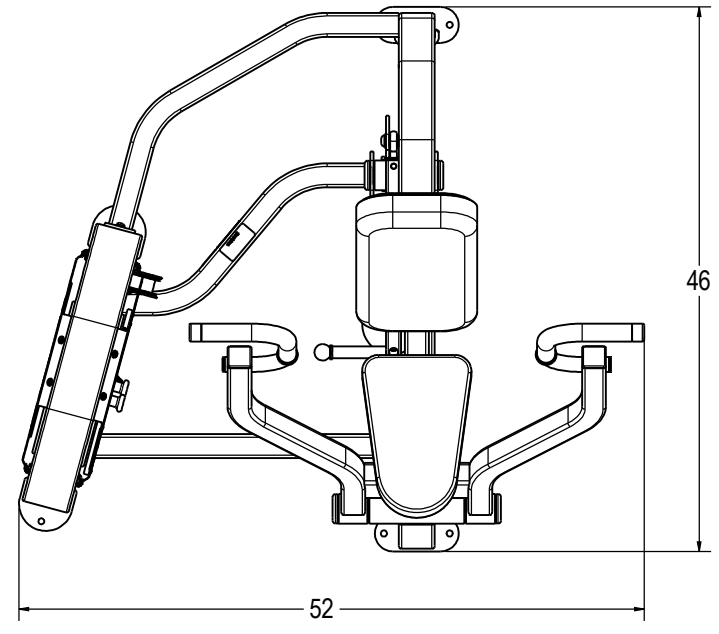

ITEM NO.	PART NUMBER	DESCRIPTION	QTY.
1	3211-0138	ASSY, WELD, MAIN FR., VERT. PRESS	1
2	3211-0139	ASSY, WELD, HANDLES, VERT PRESS	1
3	3211-0127	ASSY, WELD, LEVER ARM	1
4	3211-0336	ASSY, WELD, ROM ARM, VERT. PRESS	1
5	3210-0157	ASSY, WELD, SEAT POST	1
6	4900-PNTX	POWDER COAT, TBD	2.0 LBS.
7	3311-0392	ASSY, MECH, WT FRAME, S4301E LL	1
8	3500-0026	ASSY, BACKREST, 27X10, FC-203-A	1
9	3500-0025	ASSY, UPHOLSTERY, 13 7/8 X 8 7/8, FC-202-C	1
10	4900-UPHX	UPHOLSTERY, TBD	1.25 LIN. YDS.
11	1400-0008	TUBE, 1.50 OD, 1.25 ID, RUBBER, BLK	26.5 IN.
12	2120-0154	PLATE, BELT CLAMP, 1/4, BC-002	1
13	2120-0502	PLATE, BELT CLAMP, 1/4, BC-003	1
14	2120-3826	CAP, BEARING 2 1/2 RND ALUM	4
15	2120-3869	SHAFT, ROM PIVOT ARM	1
16	2120-3871	SHAFT, PIVOT ARM	1
17	2120-3876	CAP, HANDLE, 1 1/4	2
18	2120-3877	RING, HANDLE, 1 1/4	2
19	2120-3887	CAP, BEARING 1 3/4 RND ALUM	2
20	2120-3984	SHAFT, HANDLE PIVOT, SH. PRESS	1
21	2130-0066	COVER, PULLEY, 5"	1
22	2210-0009	BUSHING, SEAT POST	1
23	3211-0335	ASSY, WELD, ROM ADJ., INNER	1
24	3290-0001	ASSY, WELDMENT, HANDLE	1
25	4210-0030	FHSCS, 3/8-16 X .875, BRIGHT Z	4
26	4210-0031	FHSCS, 1/4-20 X .75, BRIGHT Z	2
27	4220-0005	SHCS, 1/4-20 X 1.0	4
28	4230-0048	BHSCS, 5/16-18 X 1, BRIGHT, Z	8
29	4230-0051	BHSCS, 3/8-16 X 2 1/2, BRIGHT, Z	2
30	4230-0059	BHSCS, 3/8-16 X 4 1/4, BRIGHT, Z	3
31	4230-0060	BHSCS, 3/8-16 X 2 3/4, BRIGHT, Z	2
32	4230-0069	BHSCS, 1/4-20 X 1 3/4, BRIGHT, Z	1
33	4230-0076	BHSCS, 1/2-13 X 4 3/4, BRIGHT, Z	1
34	4230-0093	BHSCS, 1/4-20 X 3/4, BRIGHT, Z	2
35	4230-0106	BHC, 5/8-11, 2.0, SHC, AS, BZ	1
36	4250-0001	SSS, 10-32 X 1/8, BLK	8
37	4250-0015	SSSCP, 1/4-20 X 1/2, BLK	2
38	4500-0004	NUT, NYLOC, 1/2-20	1
39	4500-0008	Nut, JAM, 1/4-20, Z	1
40	4500-0029	NUT, NYLOC, JAM, 3/8-16, Z	7
41	4600-0007	WASHER, SAE, 5/16, Z	8
42	4600-0008	WASHER, SAE, 1/2, Z	2
43	4600-0009	WASHER, SAE, 3/8-16, Z	14
44	4600-0017	WASHER, SAE, FLAT, 5/8, Z	1
45	4600-0023	WASHER, FLAT, 3/4, PLN	2
46	4600-0025	MACHINE BUSHING, 1", 18 GAGE	2
47	4800-0001	BELT, MECTROL, SPOOL	182 IN.
48	4900-0004	ROD END, 5/8-18	1
49	4900-0052	SPRING, O.D. 5.115, CENTURY 921	1
50	4900-0108	SLEEVE, HANDLE, RED	1
51	4900-0139	BEARING, 1 ID X 2 OD, NR16-Z	4
52	4900-0440	PULLEY, BELT, 4.75D, 3/8B, 1.5W, MOLDED	2
53	4900-0441	PULLEY, BELT, 4.75D, 1/2B, 1.5W, MOLDED	1
54	4900-0545	BEARING, 5" ID X 1.375 OD, MESA 1621DC+	2
55	4900-0554	RET. RING, 1 3/8 INT., SPIRAL	2
56	4900-0576	PULL PIN, 1/2", K-520PR	1
57	4900-0588	CAP, 2.0 X 2.0, BLACK, TEXTURED	2
58	4900-0591	CAP, Ø1.25, BLACK, TEXTURED	2
59	5220-0001	LABEL, SAFETY, KEEP HANDS, LARGE	2
60	5220-0005	LABEL, SAFETY, SECURE TO FLOOR	1
61	5220-0028	LABEL, SAFETY, PINCH POINTS	1
62	5290-0001	SERIAL NUMBER	1
63	050-2190	LABEL, PATENTS, LNL	1
64	730-0913	BUMPER	2

- NOTES:
1. INTERPRET DRAWING PER ASME Y14.5M-1994.
 2. REMOVE ALL BURRS AND SHARP EDGES .015/.030.
 3. IF APPLICABLE, CRITICAL DIMENSIONS LABELED.
 4. ALL HARDWARE KITTED PER 3700-0501.
 5. ALL UPHOLSTERY KITTED PER 3700-0083.
 6. EST. GROSS WT. 550 LBS.

DOCUMENT STATUS:
RELEASED

DRAWN	SLS	10/23/2009
CHECKED	N/A	
APPROVED		

MATERIAL
SEE BOM

FINISH
N/A

VENDOR: N/A

UNISEN, INC. DBA
STARTRAC
14410 Myford Road
Irvine CA 92606

SCALE: 1:8

14410 Myford Road
Irvine CA 92606

STARTRAC PART NO
9LL-S4301EXXXXX

REV
A

VERTICAL PRESS, LL

SHEET 1 OF 2 SHEET SIZE: D

