

| REVISION HISTORY | | | | |
|------------------|------------|--------------------|--------|-----|
| REV | DATE | DESCRIPTION | ECO | BY |
| A | 11/11/2009 | PRODUCTION RELEASE | 100596 | SLS |

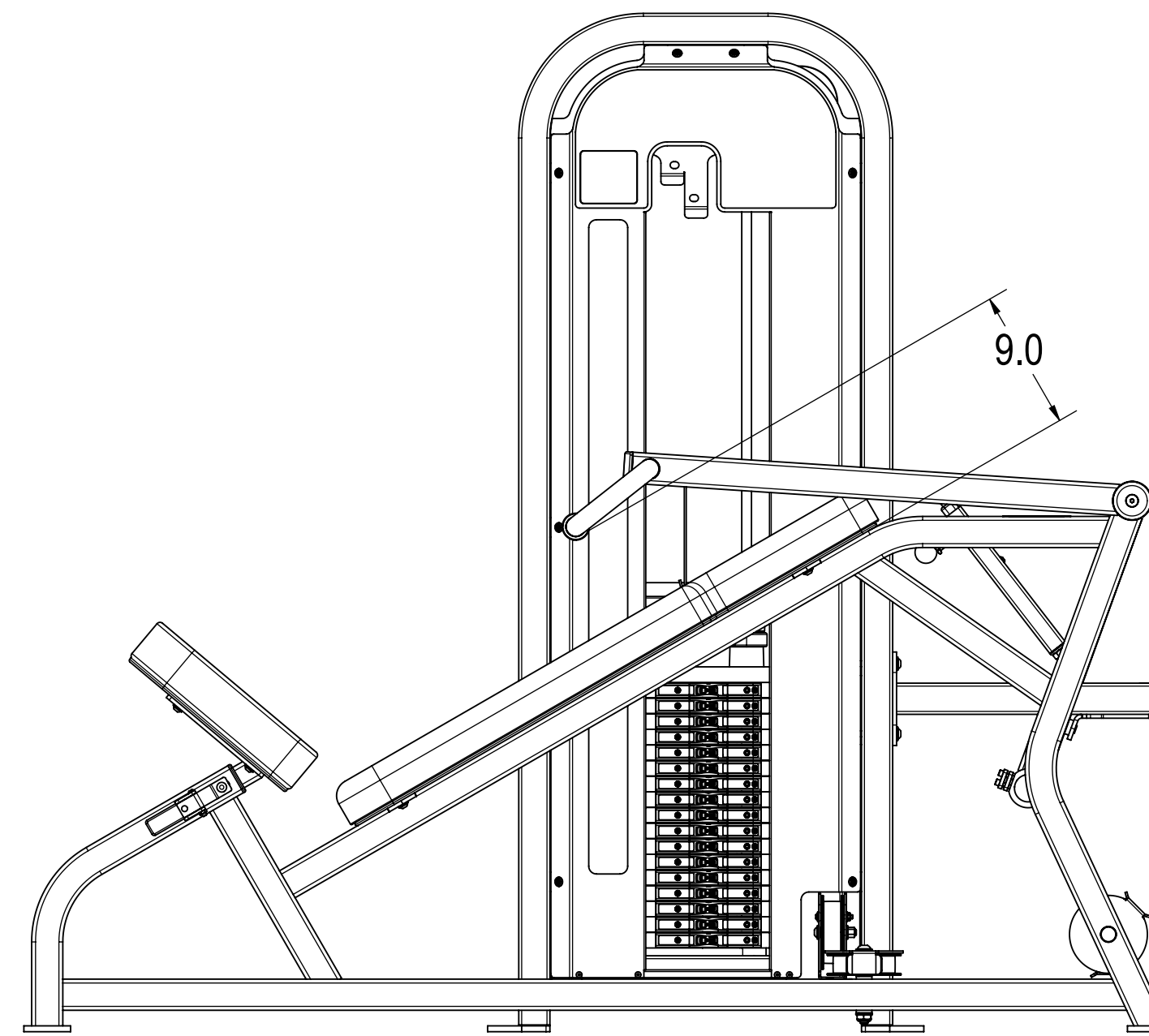
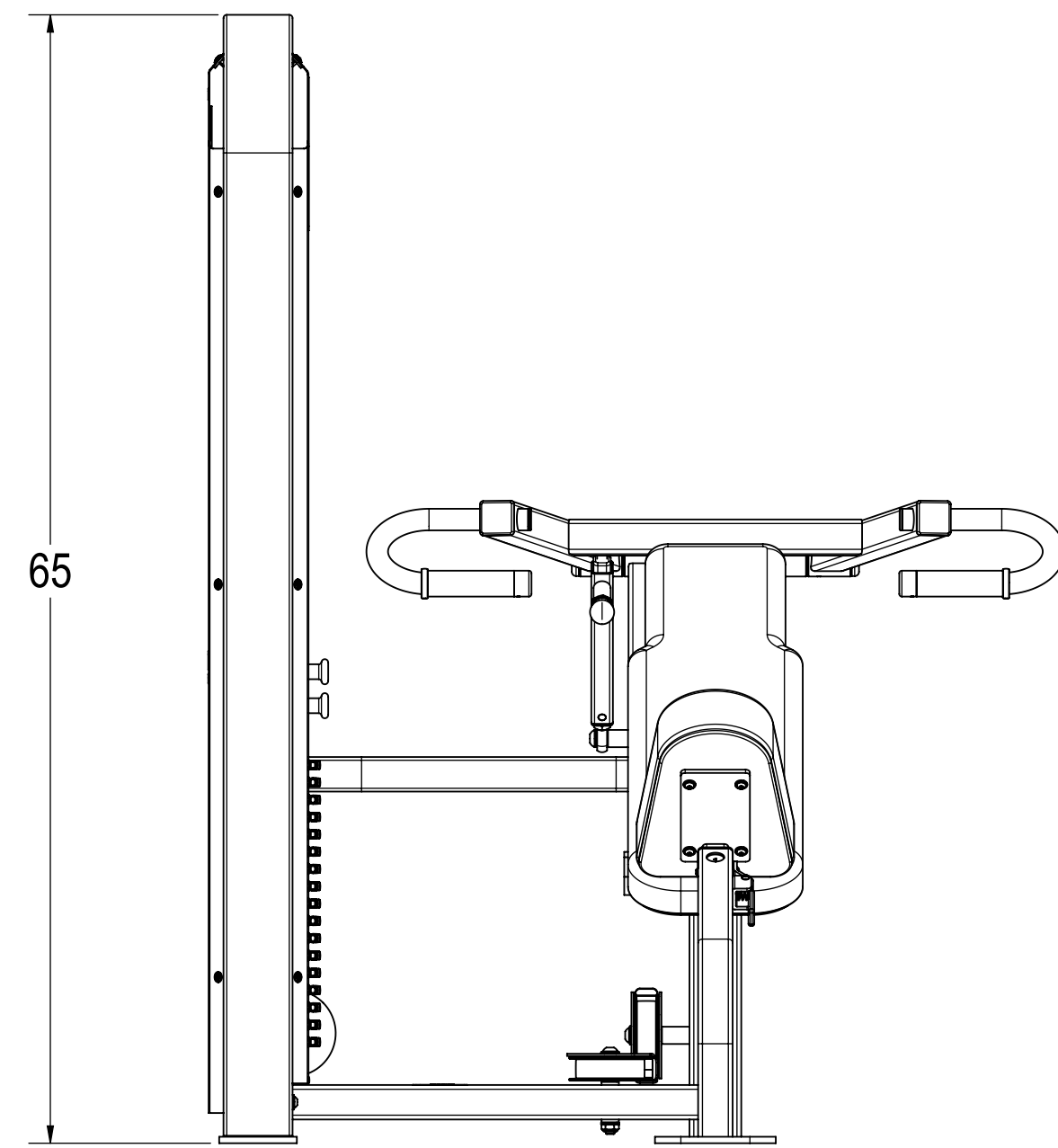
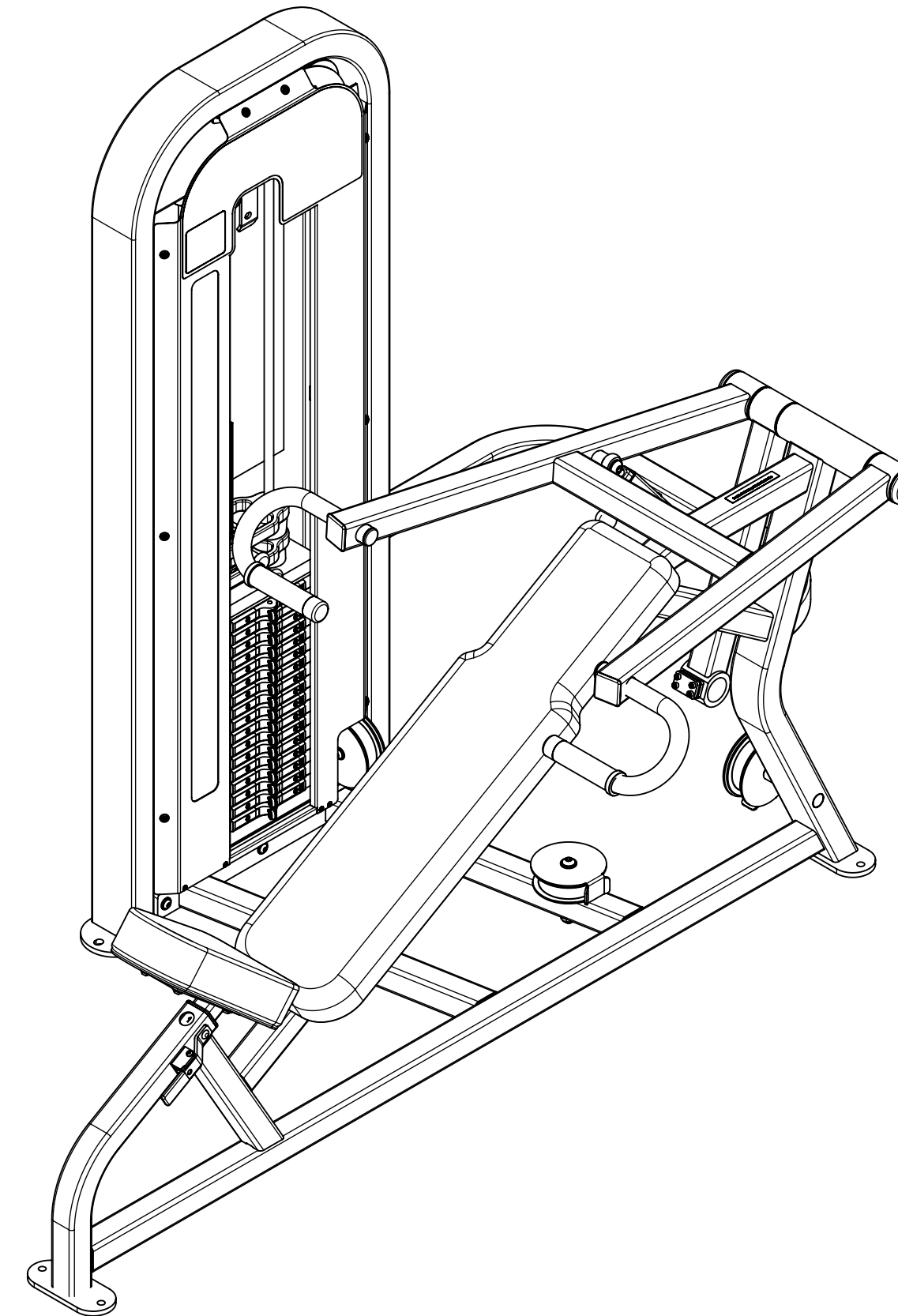
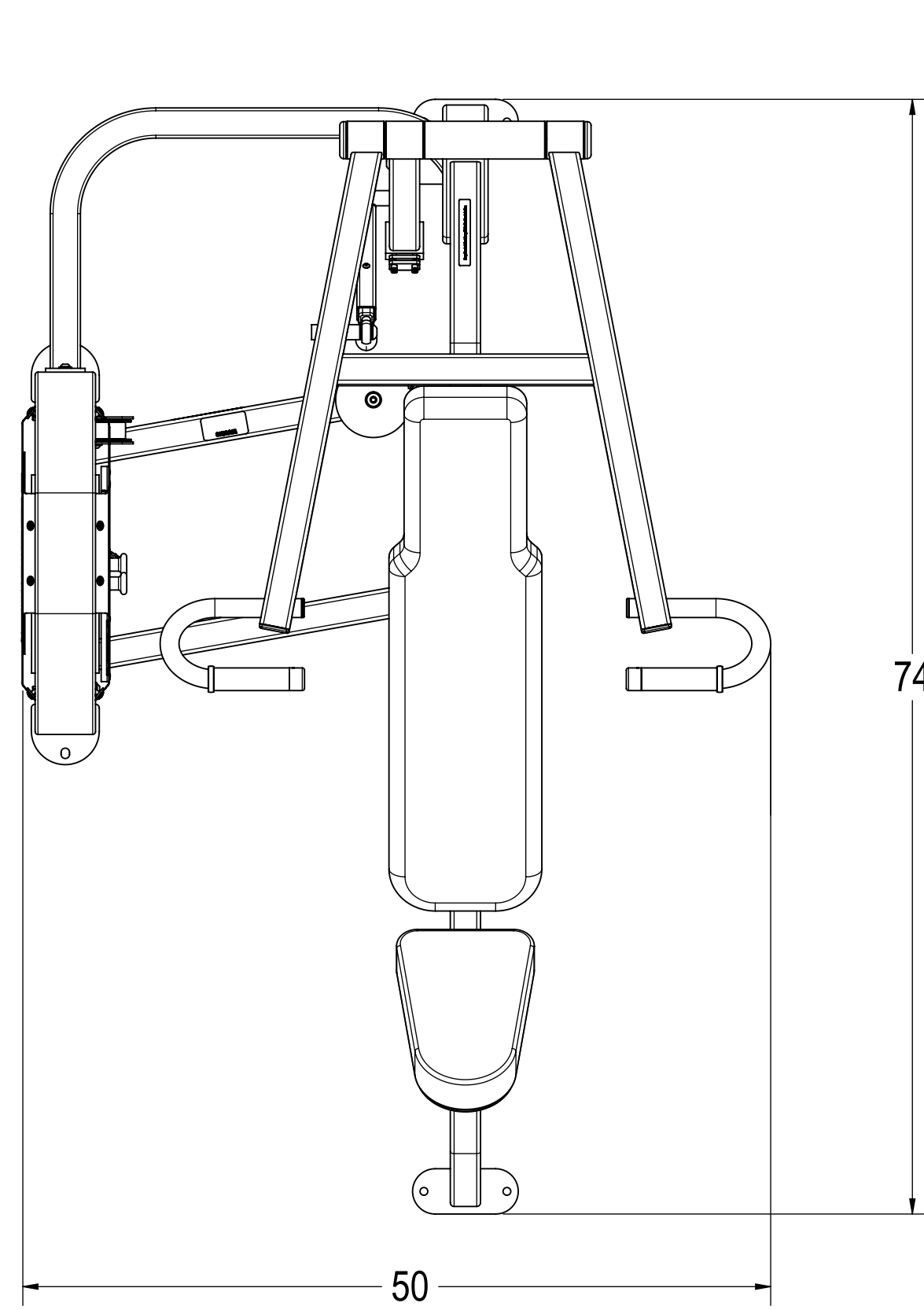

| ITEM NO. | PART NUMBER | DESCRIPTION | Default QTY. |
|----------|-------------|--|---------------|
| 1 | 3211-0163 | ASSY,WELD.MAIN FRAME,PR-S2301 | 1 |
| 2 | 3211-0161 | ASSY, WELD, HANDLES, S2301 | 1 |
| 3 | 3211-0162 | ASSY, WELD, LEVERAGE ARM, S2301 | 1 |
| 4 | 3211-0228 | ASSY, WELD, LINEAR ROM ADJ., OUTER | 1 |
| 5 | 3210-0348 | ASSY, WELD, SEAT POST, 20° | 1 |
| 6 | 4900-PNTX | POWDER COAT, TBD | 2.00 LBS. |
| 7 | 3311-0383 | ASSY.MECH.WT FRAME,S2301E LL | 1 |
| 8 | 3500-0025 | ASSY.UPHOLSTRY,13 7/8 X 8 7/8,FC-202-C | 1 |
| 9 | 3500-0069 | ASSY, UPHOLSTRY, 10x34, FS-403-A | 1 |
| 10 | 4900-UPHX | UPHOLSTRY, TBD | 1.5 LIN. YDS. |
| 11 | 1400-0008 | TUBE, 1.50 OD, 1.25 ID, RUBBER, BLK | 10 IN. |
| 12 | 2120-0154 | PLATE, BELT CLAMP, 1/4, BC-002 | 2 |
| 13 | 2120-3826 | CAP, BEARING 2 1/2 RND ALUM | 2 |
| 14 | 2120-3876 | CAP, HANDLE, 1 1/4 | 2 |
| 15 | 2120-3877 | RING, HANDLE, 1 1/4 | 2 |
| 16 | 2120-4021 | SHAFT, INC. PRESS ARM | 1 |
| 17 | 2130-0066 | COVER,PULLEY,5" | 3 |
| 18 | 2210-0009 | BUSHING, SEAT POST | 1 |
| 19 | 3211-0229 | ASSY, WELD, LINEAR ROM ADJ., INNER | 1 |
| 20 | 3290-0001 | ASSY, WELDMENT, HANDLE | 1 |
| 21 | 4210-0030 | FHSCS, 3/8-16 X .875, BRIGHT Z | 2 |
| 22 | 4220-0005 | SHCS, 1/4-20 X 1.0 | 4 |
| 23 | 4230-0059 | BHSCS, 3/8-16 X 4 1/4, BRIGHT, Z | 3 |
| 24 | 4230-0060 | BHSCS, 3/8-16 X 2 3/4, BRIGHT, Z | 2 |
| 25 | 4230-0069 | BHSCS, 1/4-20 X 1 3/4, BRIGHT, Z | 1 |
| 26 | 4230-0071 | BHSCS, 1/2-13 X 3, BRIGHT, Z | 1 |
| 27 | 4230-0076 | BHSCS, 1/2-13 X 4 3/4, BRIGHT, Z | 1 |
| 28 | 4230-0107 | BHC, 5/8-11, 2.25, SHC, AS, BZ | 2 |
| 29 | 4230-0083 | BHSCS, 5/16-18 X 1 1/4, BRIGHT, Z | 8 |
| 30 | 4230-0093 | BHSCS, 1/4-20 X 3/4, BRIGHT, Z | 2 |
| 31 | 4250-0001 | SSS, 10-32 X 1/8, BLK | 8 |
| 32 | 4250-0015 | SSSCP, 1/4-20 X 1/2, BLK | 2 |
| 33 | 4500-0001 | NUT, HEX, JAM, 5/8-18, ZINC | 1 |
| 34 | 4500-0008 | Nut, JAM, 1/4-20, Z | 1 |
| 35 | 4500-0029 | NUT,NYLOC,JAM,3/8-16,Z | 5 |
| 36 | 4500-0004 | NUT,NYLOC,1/2-20 | 1 |
| 37 | 4600-0007 | WASHER, SAE, 5/16, Z | 8 |
| 38 | 4600-0008 | WASHER, SAE, 1/2, Z | 3 |
| 39 | 4600-0009 | WASHER, SAE, 3/8-16, Z | 10 |
| 40 | 4600-0025 | MACHINE BUSHING, 1", 18 GAGE | 1 |
| 41 | 4800-0001 | BELT, MECTROL, SPOOL | 166 |
| 42 | 4900-0004 | ROD END, 5/8-18 | 2 |
| 43 | 4900-0052 | SPRING,O.D. 5.1 L.5, CENTURY 921 | 1 |
| 44 | 4900-0108 | SLEEVE, HANDLE, RED | 1 |
| 45 | 4900-0139 | BEARING, 1 ID X 2 OD, NR16-Z | 4 |
| 46 | 4900-0241 | Pull Pin, 3/8, K-100PR | 1 |
| 47 | 4900-0441 | PULLEY,BELT,4.75D,1/2B,1.5W,MOLDED | 2 |
| 48 | 4900-0588 | CAP, 2.0 X 2.0, BLACK, TEXTURED | 2 |
| 49 | 4900-0591 | CAP, Ø1.25, BLACK, TEXTURED | 2 |
| 50 | 5220-0002 | LABEL, SAFETY, KEEP HANDS, SMALL | 1 |
| 51 | 5220-0005 | LABEL, SAFETY, SECURE TO FLOOR | 1 |
| 52 | 5220-0028 | LABEL, SAFETY, PINCH POINTS | 1 |
| 53 | 5290-0001 | SERIAL NUMBER | 1 |
| 54 | 050-2190 | LABEL,PATENTS,LNL | 1 |
| 55 | 730-0913 | BUMPER | 1 |

NOTES:

1. INTERPRET DRAWING PER ASME Y14.5M-1994.
2. IF APPLICABLE, CRITICAL DIMENSIONS LABELED.
3. ALL HARDWARE IS KITTED PER 3700-0474.
4. ALL UPHOLSTERY IS KITTED PER 3700-0094.
5. EST. GROSS WT. 585 LBS.

DOCUMENT STATUS:

RELEASED

NOTICE OF PROPRIETARY INFORMATION
THIS DOCUMENT SHALL NOT BE REPRODUCED NOR SHALL THE INFORMATION CONTAINED HEREIN BE USED BY OR DISCLOSED TO OTHERS EXCEPT AS EXPRESSLY AUTHORIZED BY INISEN INC. USA, STAR TRAC.

THIRD ANGLE PROJECTION



MATERIAL
SEE BOM

FINISH
N/A

VENDOR N/A

UNLESS OTHERWISE SPECIFIED DIMENSIONS ARE IN INCHES. TOLERANCES ARE:
DECIMALS .005
FRACTIONS 1/32
ANGLES ±.5°
HOLE DIA. ±.010

INITIAL DATE
SLS 10/22/2009

CHECKED
APPROVED

U.O.M. INCH

INISEN, INC. DBA 14410 Myford Road
Irvine CA 92606

STAR TRAC
91L-S2301EXXXXX

SCALE: 1:10 SHEET 1 OF 2 SHEET SIZE: D

REV A

