

| REVISION HISTORY | | | | |
|------------------|-----------|--|-------|----|
| REV | DATE | DESCRIPTION | ECO | BY |
| A | 12/1/2011 | RELEASED @ LAND AMERICA | ---- | LA |
| B | 5/1/2012 | UPDATED THE DESIGN: WITH UPDATED WELD ASSEMBLY 731-4549. | 13691 | PG |

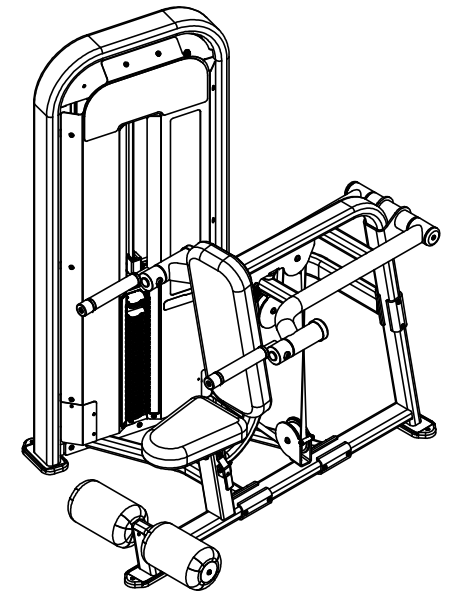
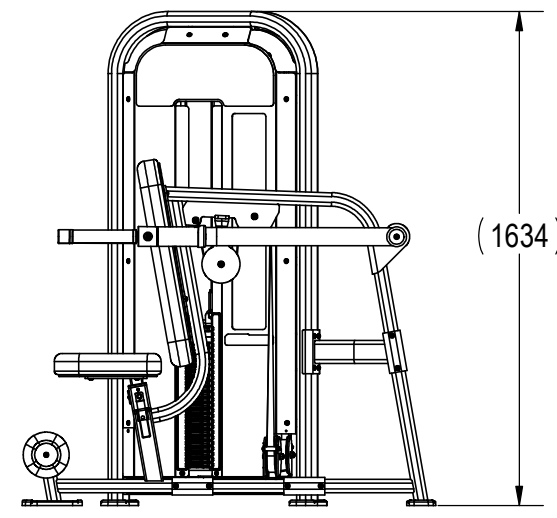
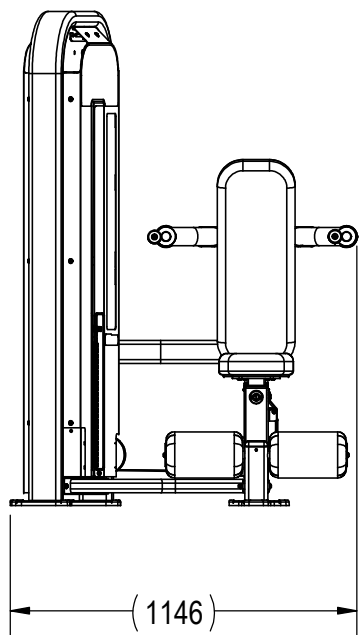
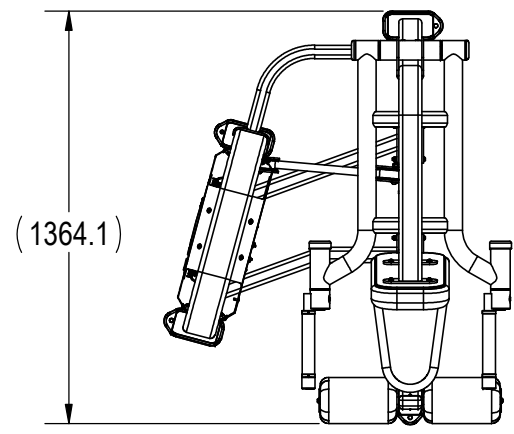

DOCUMENT STATUS:

NOTICE OF PROPRIETARY INFORMATION
 THIS DOCUMENT SHALL NOT BE REPRODUCED NOR SHALL THE INFORMATION CONTAINED HEREIN BE USED BY OR DISCLOSED TO OTHER EXCEPT AS EXPRESSLY AUTHORIZED BY CORE INDUSTRIES, INC., D.B.A. STAR TRAC.

NOTES:
 1. ASSEMBLE AND INSPECT PER SOP 620-7918.

| CLASS OF WORK | UNLESS OTHERWISE SPECIFIED DIMS ARE IN mm. TOLERANCES FOR MEASURE OF LENGTH ARE: | | | | | | | ANGLES = ±2° |
|-----------------|--|---------|----------|------------|-------------|--------------|---------------|--------------|
| | 0.5 to 3 | >3 to 6 | >6 to 30 | >30 to 120 | >120 to 400 | >400 to 1000 | >1000 to 2000 | |
| FINE | ±0.05 | ±0.05 | ±0.1 | ±0.15 | ±0.2 | ±0.3 | ±0.5 | ---- |
| MEDIUM X | ±0.1 | ±0.1 | ±0.2 | ±0.3 | ±0.5 | ±0.8 | ±1.2 | ±2 |
| COARSE | ±0.2 | ±0.3 | ±0.5 | ±0.8 | ±1.2 | ±2 | ±3 | ±4 |
| VERY COARSE | ---- | ±0.5 | ±1 | ±1.5 | ±2.5 | ±4 | ±6 | ±8 |

| | | |
|----------------------------|-----------------------------------|------------------|
| MATERIAL SEE BOM | THIRD ANGLE PROJECTION | |
| FINISH N/A | DRAWN | INITIAL PG |
| VENDOR: N/A | CHECKED | DATE 10/23/12 |
| P/N: N/A | APPROVED | |
| | U.O.M. | MM |

| | | | |
|--------------------------------------|-----------------------|--------------------------------------|----------|
| CORE INDUSTRIES, INC. DBA | | 14410 Myford Road Irvine CA 92606 | |
| STARTRAC PART NO | LA-S5303-XXXXS | REV | B |
| TITLE LA,SSS,DIP MACHINE | | | |
| SCALE: 1:25 | SHEET 1 OF 9 | SHEET SIZE: B | |

SHEET
4

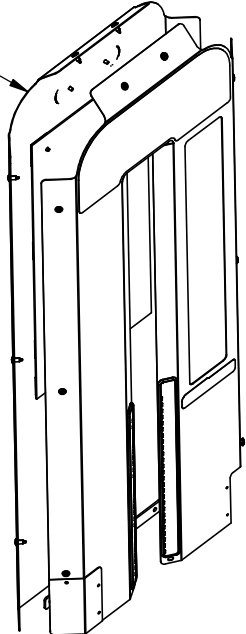

SHEET
5

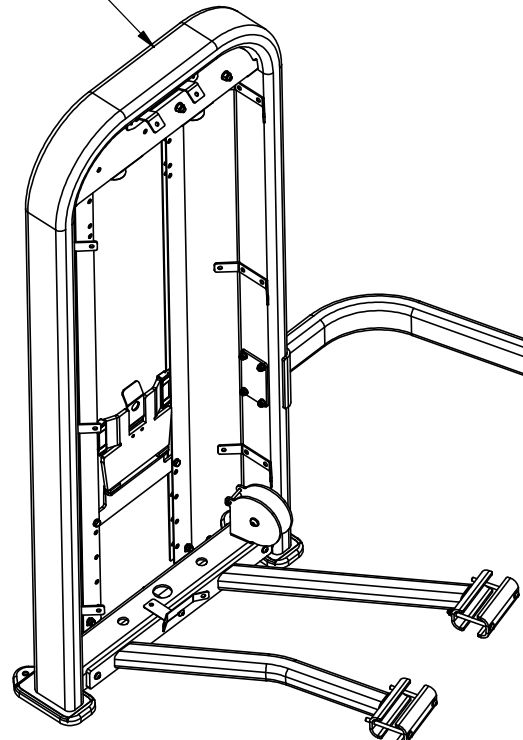

SHEET
6

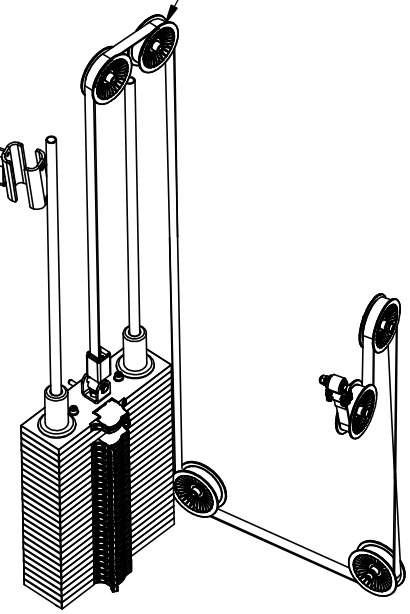

SHEET
7

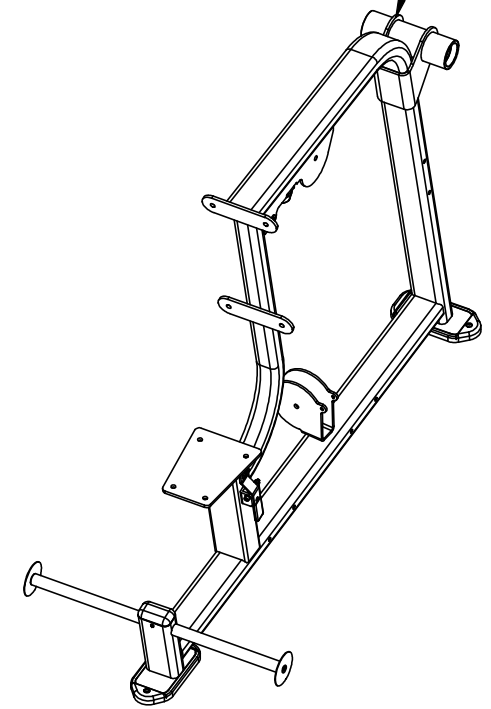

SHEET
9

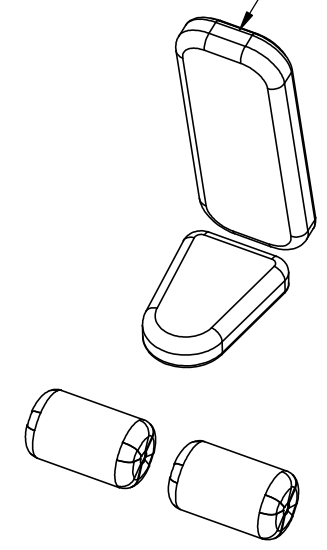

SHEET
8

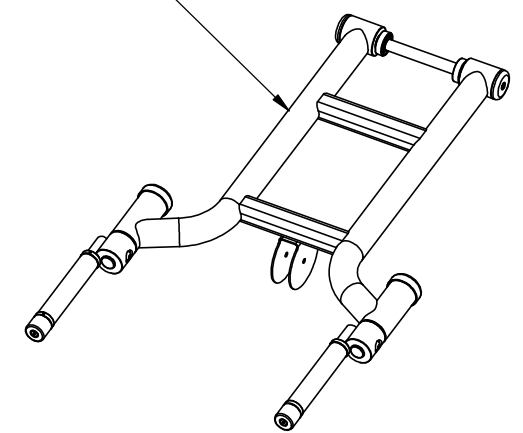

| | | |
|-----------------------------|-----------------------|-------------------|
| CORE INDUSTRIES, INC. DBA | | 14410 Myford Road |
| | | Irvine CA 92606 |
| STARTRAC PART NO | LA-S5303-XXXXS | REV B |
| TITLE LA,SSS,DIP MACHINE | | |
| SCALE: 1:25 | SHEET 3 OF 9 | SHEET SIZE: B |

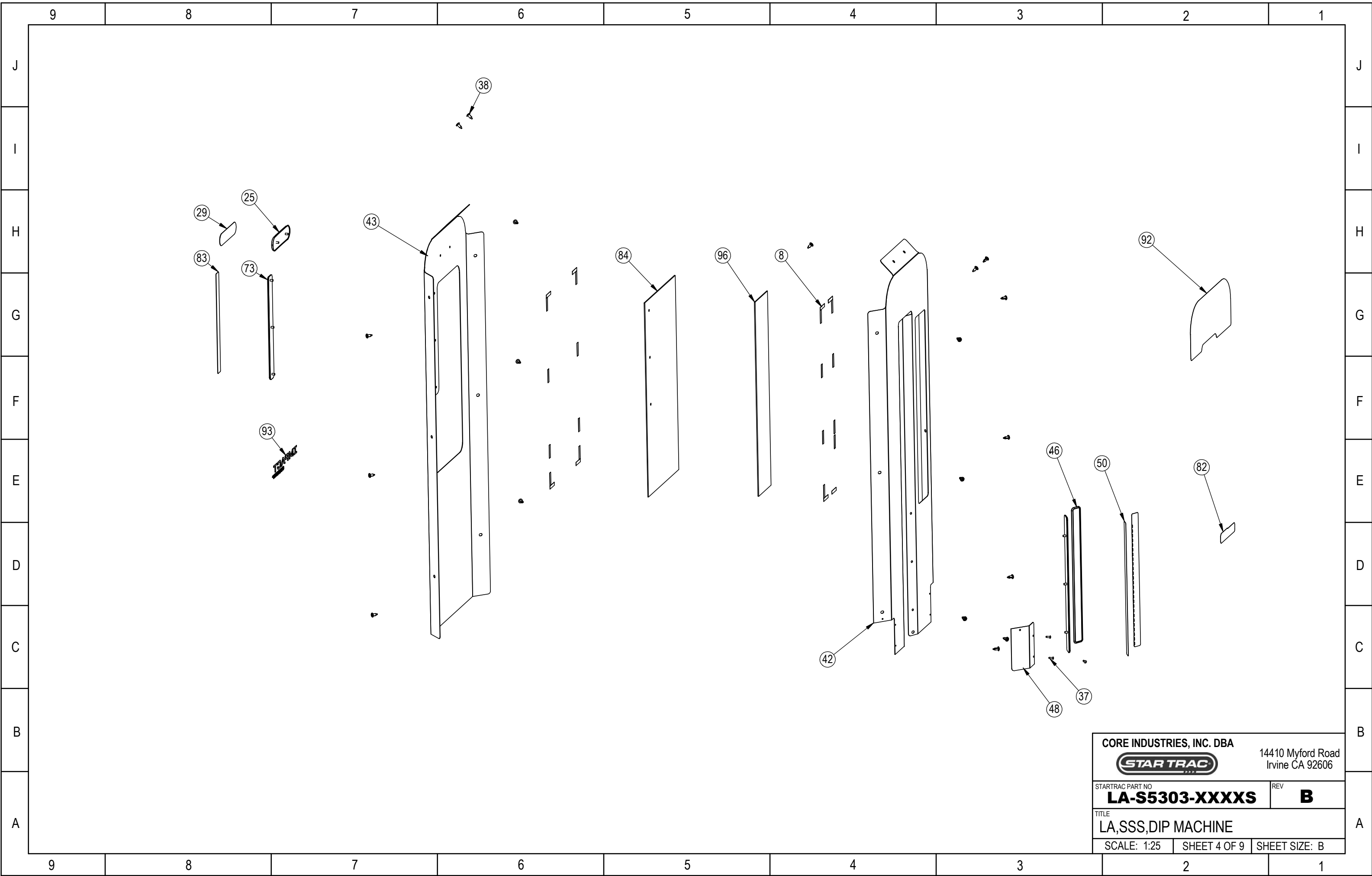

CORE INDUSTRIES, INC. DBA
STAR TRAC
 14410 Myford Road
 Irvine CA 92606

STARTRAC PART NO
LA-S5303-XXXXS
 TITLE
LA,SSS,DIP MACHINE

REV
B

SCALE: 1:25 SHEET 4 OF 9 SHEET SIZE: B

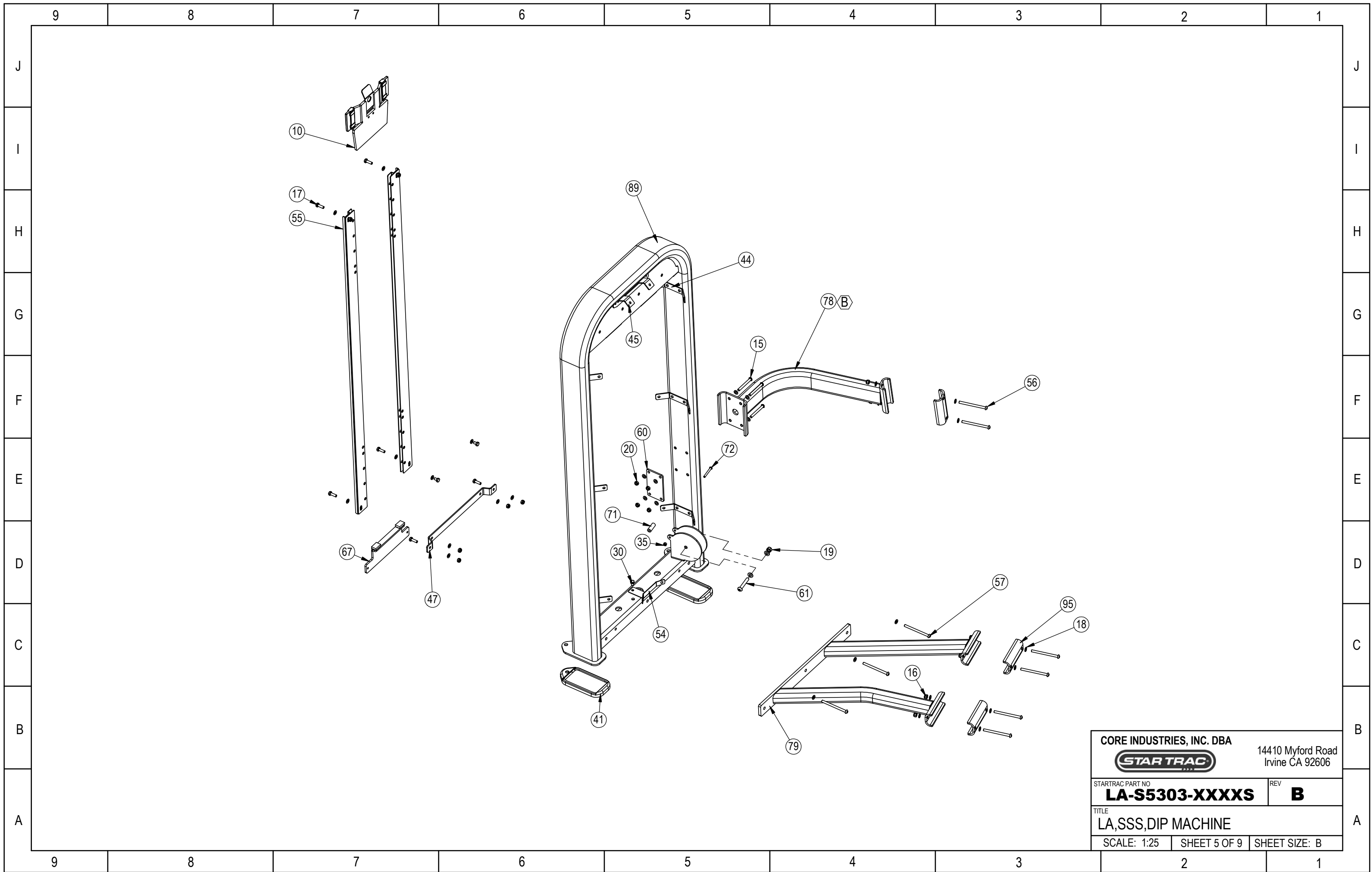

| | | |
|-----------------------------|-----------------------|-------------------|
| CORE INDUSTRIES, INC. DBA | | 14410 Myford Road |
| STAR TRAC | | Irvine CA 92606 |
| STARTRAC PART NO | LA-S5303-XXXXS | REV B |
| TITLE LA,SSS,DIP MACHINE | | |
| SCALE: 1:25 | SHEET 5 OF 9 | SHEET SIZE: B |

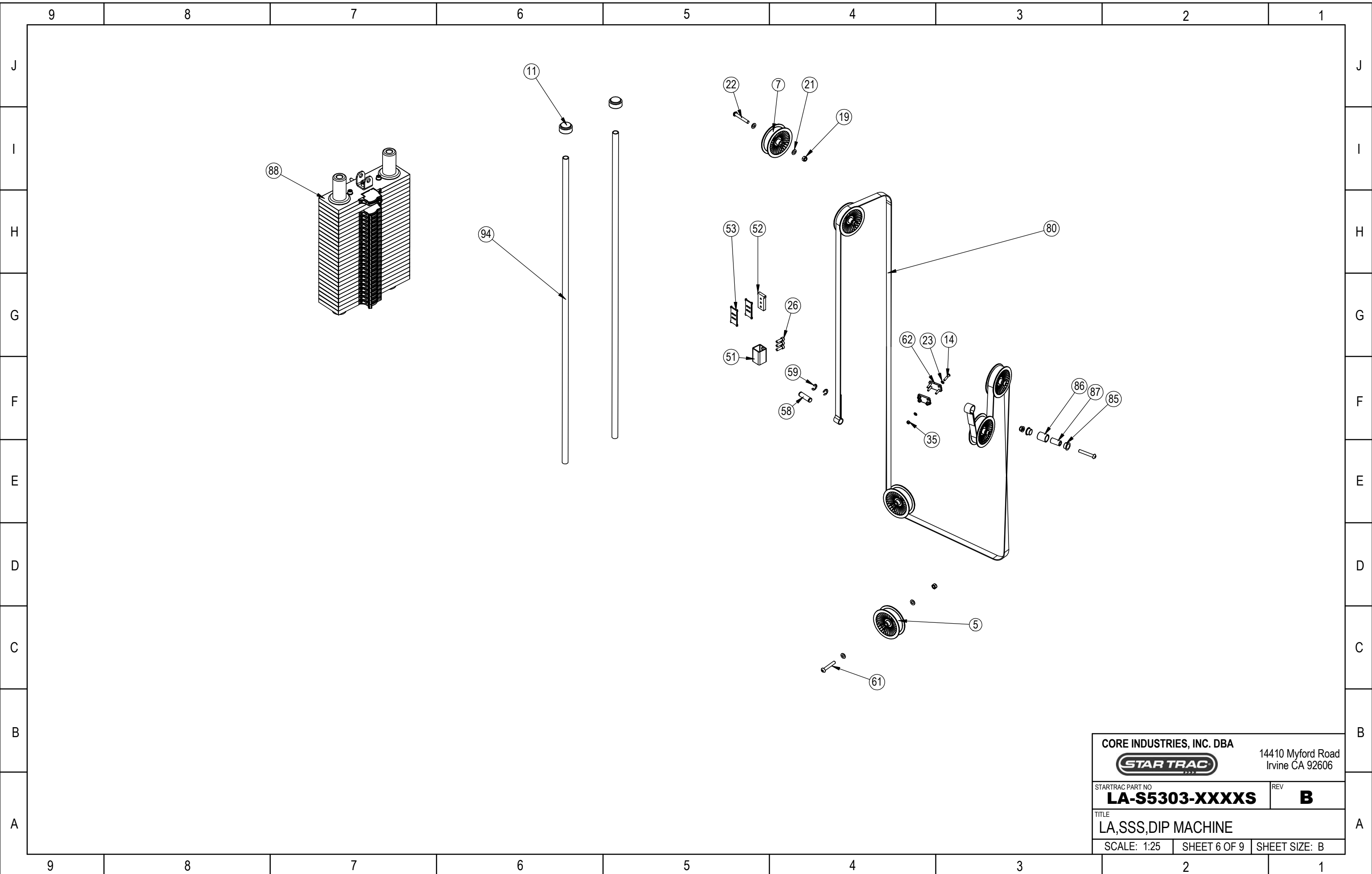

CORE INDUSTRIES, INC. DBA
STAR TRAC
 14410 Myford Road
 Irvine CA 92606

STARTRAC PART NO
LA-S5303-XXXXS
 TITLE
LA,SSS,DIP MACHINE

REV
B
 SCALE: 1:25 SHEET 6 OF 9 SHEET SIZE: B

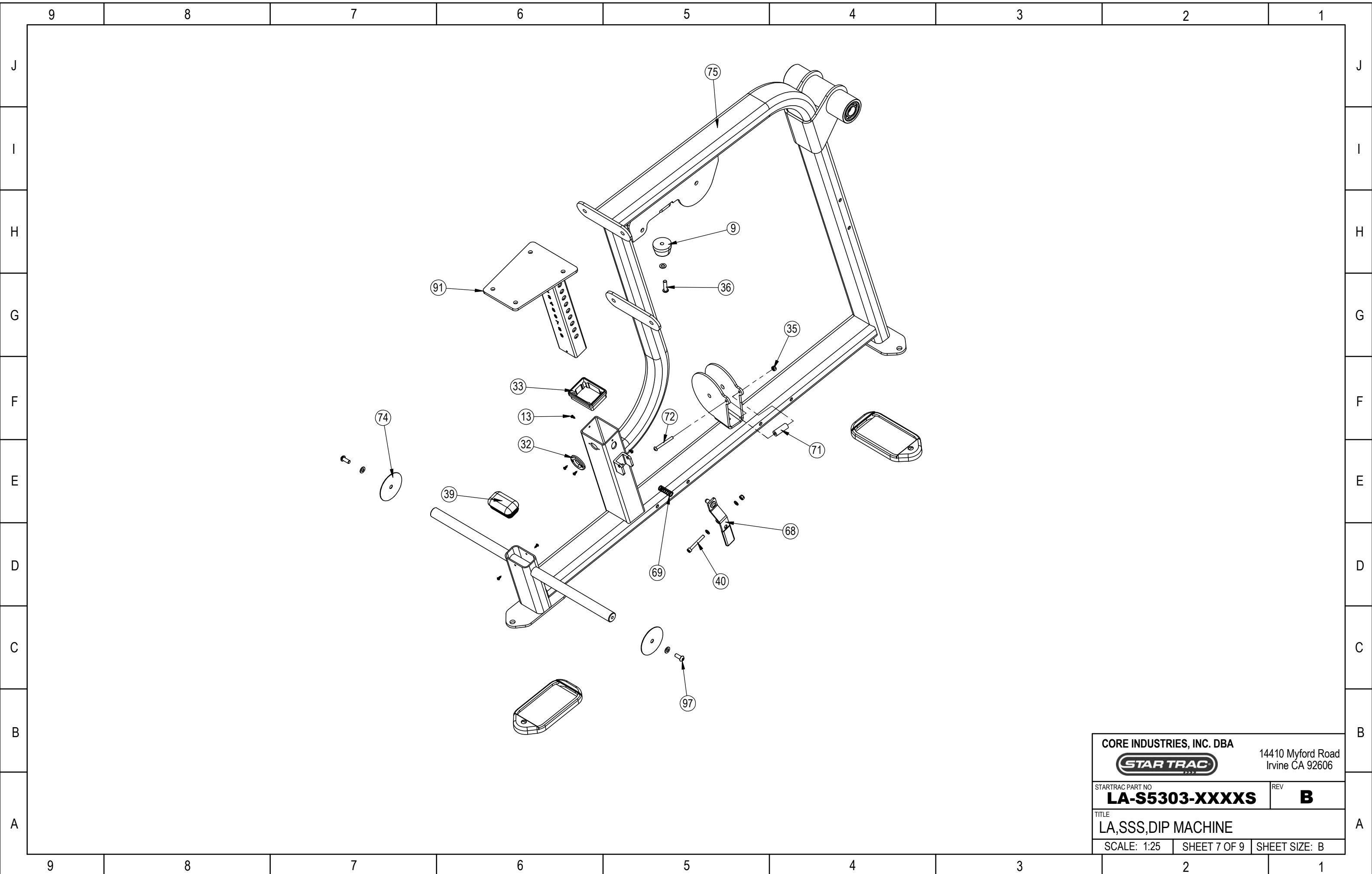

| | | | |
|-----------------------------|-----------------------|--------------------------------------|----------|
| CORE INDUSTRIES, INC. DBA | | 14410 Myford Road Irvine CA 92606 | |
| | | | |
| STARTRAC PART NO | LA-S5303-XXXXS | REV | B |
| TITLE LA,SSS,DIP MACHINE | | | |
| SCALE: 1:25 | SHEET 7 OF 9 | SHEET SIZE: B | |

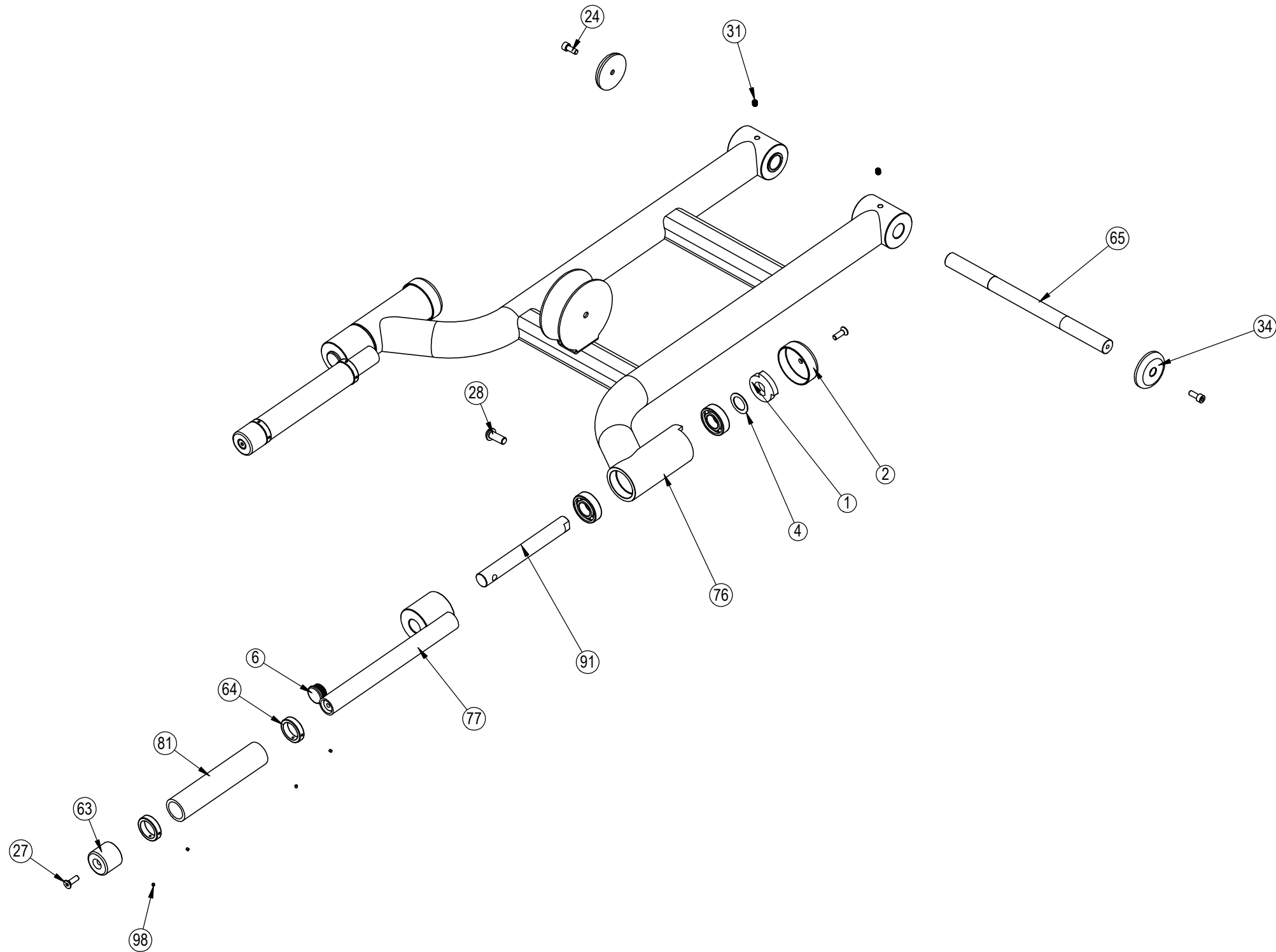

| | | | |
|-----------------------------|-----------------------|--------------------------------------|----------|
| CORE INDUSTRIES, INC. DBA | | 14410 Myford Road Irvine CA 92606 | |
| | | | |
| STARTRAC PART NO | LA-S5303-XXXXS | REV | B |
| TITLE LA,SSS,DIP MACHINE | | | |
| SCALE: 1:25 | SHEET 8 OF 9 | SHEET SIZE: B | |

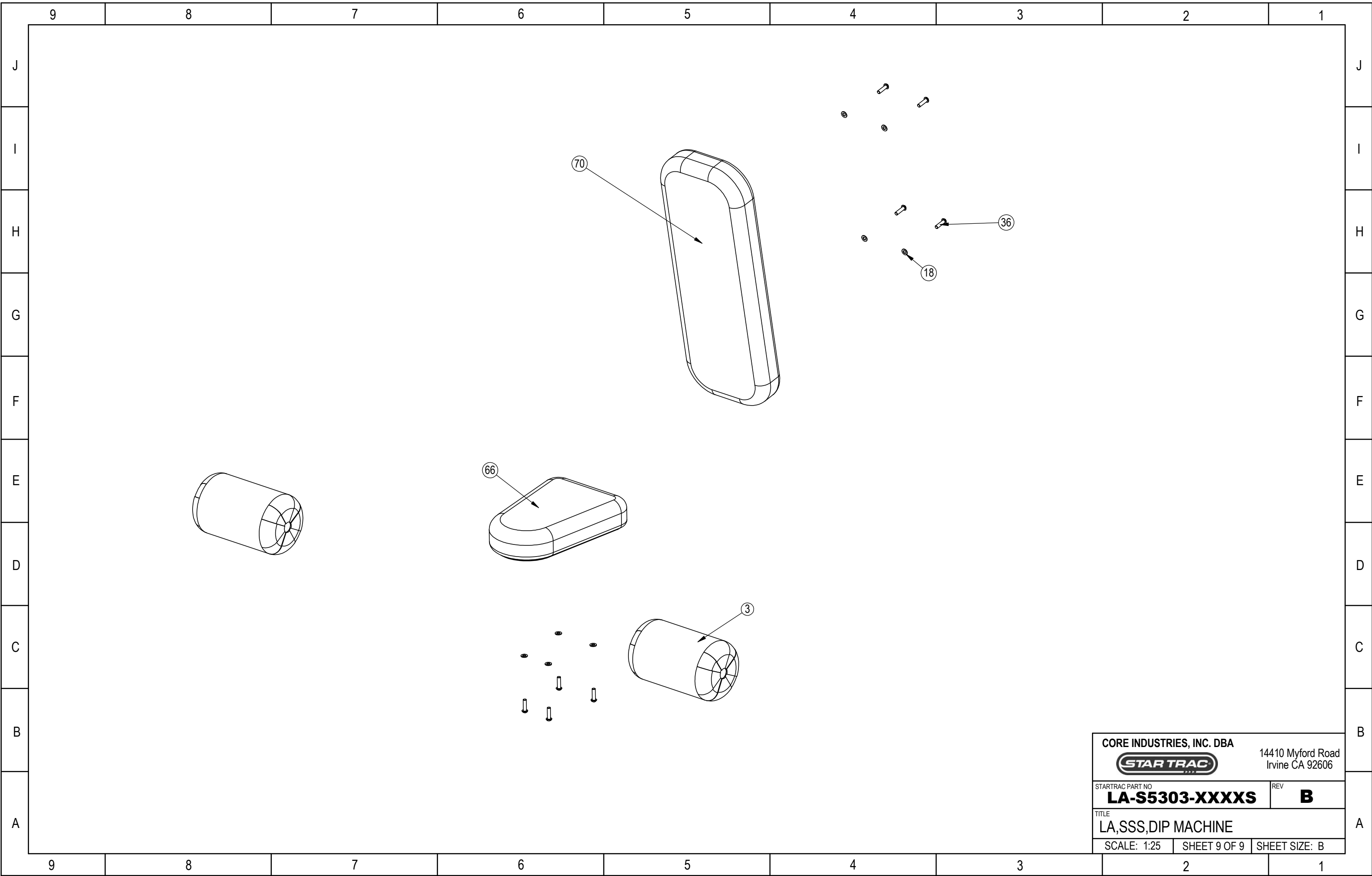

| | | |
|-----------------------------|-----------------------|-------------------|
| CORE INDUSTRIES, INC. DBA | | 14410 Myford Road |
| | | Irvine CA 92606 |
| STARTRAC PART NO | LA-S5303-XXXXS | REV B |
| TITLE LA,SSS,DIP MACHINE | | |
| SCALE: 1:25 | SHEET 9 OF 9 | SHEET SIZE: B |