

9 8 7 6 5 4 3 2 1

REVISION HISTORY				
REV	DATE	DESCRIPTION	ECO	BY
A	8/1/12	RELEASED FOR PRODUCTION	13682	KEY

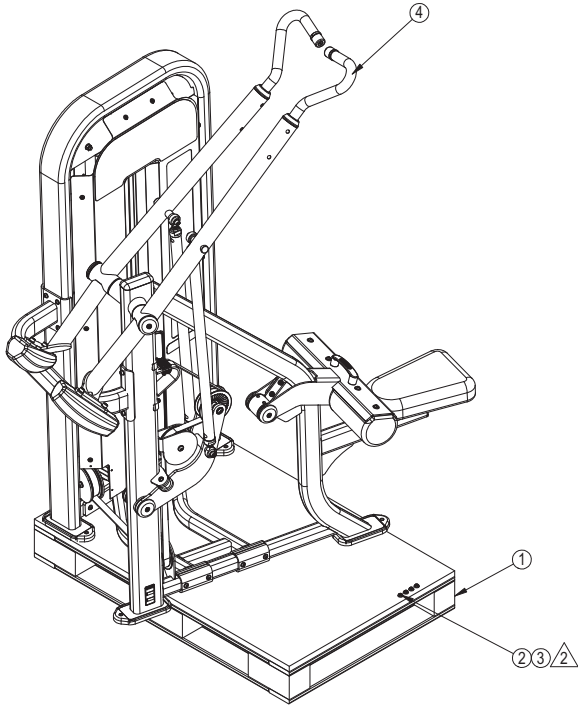

NOTICE OF PROPRIETARY INFORMATION
 THIS DOCUMENT SHALL NOT BE REPRODUCED NOR SHALL THE INFORMATION CONTAINED HEREIN BE USED BY OR DISCLOSED TO OTHER EXCEPT AS EXPRESSLY AUTHORIZED BY CORE INDUSTRIES, INC. D.B.A. STAR TRAC.

DOCUMENT STATUS:

ITEM NO.	PART NUMBER	DESCRIPTION	QTY.
1	731-0178	PALLET,765 x 1180 x 152	1
2	731-0256	SCREW,M6,25mm,W,HE,ZP	4
3	731-0294	WASHER,M8,NYLON	4
4	LA-S3303-XXXXS	LA, SSS, FIXED LAT PULL DOWN	1

- NOTES:**
- PLACE SHIPPING LABELS ON PACKAGED UNIT BEFORE SHRINK WRAPPING.
 - USE ITEMS 2,3 TO SECURE ITEM 4 TO PALLET (ITEM 1), PLACING ITEM 3 AGAINST POWDERCOAT OF ITEM 4.
 - ITEM 4 NOT SHOWN IN PACKAGED CONFIGURATION.

CLASS OF WORK	UNLESS OTHERWISE SPECIFIED DIMS ARE IN mm. TOLERANCES FOR MEASURE OF LENGTH ARE:							ANGLES = ±2°		MATERIAL SEE BOM
	0.5 to 3	> 3 to 6	> 6 to 30	> 30 to 120	> 120 to 400	> 400 to 1000	> 1000 to 2000	> 2000		
FINE	±0.05	±0.05	±0.1	±0.15	±0.2	±0.3	±0.5	----		
MEDIUM X	±0.1	±0.1	±0.2	±0.3	±0.5	±0.8	±1.2	±2	FINISH N/A	
COARSE	±0.2	±0.3	±0.5	±0.8	±1.2	±2	±3	±4		
VERY COARSE	----	±0.5	±1	±1.5	±2.5	±4	±6	±8	VENDOR: N/A P/N: N/A	

THIRD ANGLE PROJECTION

DRAWN: KEY INITIAL: KEY DATE: 8/27/12

CHECKED: APPROVED:

CORE INDUSTRIES, INC. DBA

 14410 Myford Road
 Irvine CA 92606

STARTRAC PART NO: **9LA-S3303-XXXXS** REV: **A**

TITLE: **LA, SSS, FIXED LAT PULL DOWN**

SCALE: 1:50 SHEET 1 OF 1 SHEET SIZE: B

9 8 7 6 5 4 3 2 1