

REVISION HISTORY				
REV	DATE	DESCRIPTION	ECO	BY
A	12/1/2011	RELEASED @ LAND AMERICA		LA
B	7/20/2012	UPDATE DESIGN	13680	KEY

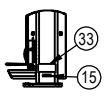
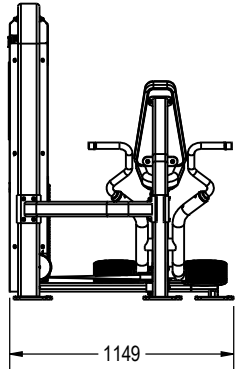
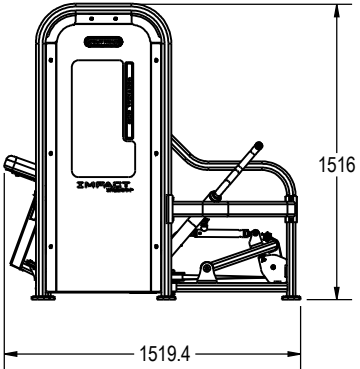
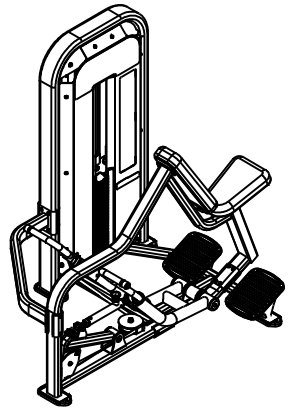
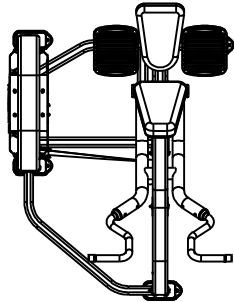

SECTION D-D

NOTICE OF PROPRIETARY INFORMATION  
 THIS DOCUMENT SHALL NOT BE REPRODUCED NOR SHALL THE INFORMATION CONTAINED HEREIN BE USED BY OR DISCLOSED TO OTHER EXCEPT AS EXPRESSLY AUTHORIZED BY CORE INDUSTRIES, INC., D.B.A. STAR TRAC.

**DOCUMENT STATUS:  
DEVELOPMENT**

- NOTES:
- ASSEMBLE AND INSPECT PER SOP 620-7918.
  - INSTALL Kg STICKER AND AFFIX Lb STICKER TO INSIDE OF SHROUD WITH TAPE.

CLASS OF WORK	UNLESS OTHERWISE SPECIFIED DIMS ARE IN mm. TOLERANCES FOR MEASURE OF LENGTH ARE:							ANGLES = ±2°		
	0.5 to 3	> 3 to 6	> 6 to 30	> 30 to 120	> 120 to 400	> 400 to 1000	> 1000 to 2000	> 2000		
FINE	±0.05	±0.05	±0.1	±0.15	±0.2	±0.3	±0.5	----		
MEDIUM	±0.1	±0.1	±0.2	±0.3	±0.5	±0.8	±1.2	±2		
COARSE	±0.2	±0.3	±0.5	±0.8	±1.2	±2	±3	±4		
VERY COARSE	----	±0.5	±1	±1.5	±2.5	±4	±6	±8		

<b>MATERIAL</b> SEE BOM	<b>FINISH</b> N/A	<b>VENDOR:</b> N/A	<b>P/N:</b> N/A
----------------------------	----------------------	--------------------	-----------------

THIRD ANGLE PROJECTION		
	INITIAL	DATE
	KEY	7/20/12
CHECKED		
APPROVED		
U.O.M.	MM	

CORE INDUSTRIES, INC. DBA		14410 Myford Road Irvine CA 92606	
		STARTRAC PART NO	REV
		<b>LA-S3301-XXXXS</b>	<b>007</b>
TITLE <b>VERTICAL ROW</b>			
SCALE: 1:25	SHEET 1 OF 9	SHEET SIZE: B	

	9				8				7				6				5				4				3				2				1			
	ITEM NO.	PART NUMBER	DESCRIPTION	Default/ QTY.	ITEM NO.	PART NUMBER	DESCRIPTION	Default/ QTY.	ITEM NO.	PART NUMBER	DESCRIPTION	Default/ QTY.	ITEM NO.	PART NUMBER	DESCRIPTION	Default/ QTY.	ITEM NO.	PART NUMBER	DESCRIPTION	Default/ QTY.	ITEM NO.	PART NUMBER	DESCRIPTION	Default/ QTY.	ITEM NO.	PART NUMBER	DESCRIPTION	Default/ QTY.	ITEM NO.	PART NUMBER	DESCRIPTION	Default/ QTY.				
J	1	4900-0440	PULLEY,BELT,4.75D,3/8B,1.5W,MOLDED	2	46	731-2079	SCREW,M4 X .7,8MM,SHC,HK,NP	2	91	731-4039	SCREW,M6,35MM,SHCS,HK,CS,BZ	4	92	731-4040	ASSY,WGT FRAME,3301	1	93	731-4042-00XX	ASSY,UPHOLSTERY,265 x 480	1	94	731-4043	SHAFT, Ø20mm X 78.75mm, D CUT	1	95	731-4045	SHAFT, 25MM X 266.5	1	96	731-4046	BELT,3301	1				
I	2	4900-0441	PULLEY,BELT,4.75D,1/2B,1.5W,MOLDED	1	47	731-2080	BUMPER,ADJ,HYPER	1	97	731-4047	STICKER,NAME,VERTICAL ROW	1	98	731-4052	CLAMSHELL,76.2X105 HS NO BREATHER	1	99	731-4053	GRIP,3301	2	100	731-4636	SCREW,M8 X 1.25,10X50MM,SHSS,HK,NP	2	101	731-4780	STICKER,LOCK N LOAD,IMPACT	1	102	731-4882	WINDOW,IMP,SHORT	1				
H	3	4900-0620	PULLEY,BELT,4.75D,3/8B,1.74W,MOLDED	2	48	731-2523	SCREW,M6,50MM,SHCS,HK,CS,BZ	1	99	731-4053	GRIP,3301	2	100	731-4636	SCREW,M8 X 1.25,10X50MM,SHSS,HK,NP	2	101	731-4780	STICKER,LOCK N LOAD,IMPACT	1	102	731-4882	WINDOW,IMP,SHORT	1	103	731-4953	PLACARD,IMPACT,VERTICAL ROW	1	104	731-5161	STICKER, IMPACT STRENGTH	1				
G	4	4900-0626	TAPE, 3M VHB 5925	1000	49	731-2622	BAR,BUSHING,MISS-ALIGNMENT	4	101	731-4780	STICKER,LOCK N LOAD,IMPACT	1	102	731-4882	WINDOW,IMP,SHORT	1	103	731-4953	PLACARD,IMPACT,VERTICAL ROW	1	104	731-5161	STICKER, IMPACT STRENGTH	1	105	731-5184	PLATE,FOOT PAD, 8MM	2	106	731-5186	SCREW,M8 X 1.25, 12MM, SHC, HK, CS, NP	8				
F	5	730-0913	BUMPER,DIA 25MM	1	50	731-2647	FOOT,LONG,LEVERAGE	4	103	731-4882	WINDOW,IMP,SHORT	1	104	731-5161	STICKER, IMPACT STRENGTH	1	105	731-5184	PLATE,FOOT PAD, 8MM	2	106	731-5186	SCREW,M8 X 1.25, 12MM, SHC, HK, CS, NP	8	107	731-5217	WINDOW,INSIDE,IMPACT,IMP,SHORT	1	108	731-5217	WINDOW,INSIDE,IMPACT,IMP,SHORT	1				
E	6	731-0033	NUT, RIVET,M8 X 1.25	1	51	731-3109	SHROUD,INSIDE,TALL,IMP	1	105	731-5184	PLATE,FOOT PAD, 8MM	2	106	731-5186	SCREW,M8 X 1.25, 12MM, SHC, HK, CS, NP	8	107	731-5217	WINDOW,INSIDE,IMPACT,IMP,SHORT	1	108	731-5217	WINDOW,INSIDE,IMPACT,IMP,SHORT	1	109	731-5217	WINDOW,INSIDE,IMPACT,IMP,SHORT	1	110	731-5217	WINDOW,INSIDE,IMPACT,IMP,SHORT	1				
D	7	731-0034	WASHER,M8,34MM OD,1.5MM THK	2	52	731-3111	SHROUD,OUTSIDE,SHORT,IMP	1	106	731-5186	SCREW,M8 X 1.25, 12MM, SHC, HK, CS, NP	8	107	731-5217	WINDOW,INSIDE,IMPACT,IMP,SHORT	1	108	731-5217	WINDOW,INSIDE,IMPACT,IMP,SHORT	1	109	731-5217	WINDOW,INSIDE,IMPACT,IMP,SHORT	1	110	731-5217	WINDOW,INSIDE,IMPACT,IMP,SHORT	1	111	731-5217	WINDOW,INSIDE,IMPACT,IMP,SHORT	1				
C	8	731-0113	ASSY,2.5Kg,ADD ON	1	53	731-3113	BRKT,SHROUD,IMP	6	107	731-5217	WINDOW,INSIDE,IMPACT,IMP,SHORT	1	108	731-5217	WINDOW,INSIDE,IMPACT,IMP,SHORT	1	109	731-5217	WINDOW,INSIDE,IMPACT,IMP,SHORT	1	110	731-5217	WINDOW,INSIDE,IMPACT,IMP,SHORT	1	111	731-5217	WINDOW,INSIDE,IMPACT,IMP,SHORT	1	112	731-5217	WINDOW,INSIDE,IMPACT,IMP,SHORT	1				
B	9	731-0119	NUT,M12X1.75, NYLOC	1	54	731-3114	BRKT, SHROUD, UPPER,IMP	2	108	731-5217	WINDOW,INSIDE,IMPACT,IMP,SHORT	1	109	731-5217	WINDOW,INSIDE,IMPACT,IMP,SHORT	1	110	731-5217	WINDOW,INSIDE,IMPACT,IMP,SHORT	1	111	731-5217	WINDOW,INSIDE,IMPACT,IMP,SHORT	1	112	731-5217	WINDOW,INSIDE,IMPACT,IMP,SHORT	1	113	731-5217	WINDOW,INSIDE,IMPACT,IMP,SHORT	1				
A	10	731-0124	CAP,GUIDE ROD,RUBBER	2	55	731-3115	HOUSING,PLASTIC,WGT STACK,IMP	2	109	731-5217	WINDOW,INSIDE,IMPACT,IMP,SHORT	1	110	731-5217	WINDOW,INSIDE,IMPACT,IMP,SHORT	1	111	731-5217	WINDOW,INSIDE,IMPACT,IMP,SHORT	1	112	731-5217	WINDOW,INSIDE,IMPACT,IMP,SHORT	1	113	731-5217	WINDOW,INSIDE,IMPACT,IMP,SHORT	1	114	731-5217	WINDOW,INSIDE,IMPACT,IMP,SHORT	1				
	11	731-0137	BEARING,52 OD,25 ID,X 15MM	4	56	731-3116	BRKT,MOUNT,LOWER,INCR CHNL,IMP	1	110	731-5217	WINDOW,INSIDE,IMPACT,IMP,SHORT	1	111	731-5217	WINDOW,INSIDE,IMPACT,IMP,SHORT	1	112	731-5217	WINDOW,INSIDE,IMPACT,IMP,SHORT	1	113	731-5217	WINDOW,INSIDE,IMPACT,IMP,SHORT	1	114	731-5217	WINDOW,INSIDE,IMPACT,IMP,SHORT	1	115	731-5217	WINDOW,INSIDE,IMPACT,IMP,SHORT	1				
	12	731-0225	SCREW,M3.5 X 9.5,SELF TAPPING	4	57	731-3122	BRKT,MOUNT,UPPER,INCR.CHAN,IMP.	1	111	731-5217	WINDOW,INSIDE,IMPACT,IMP,SHORT	1	112	731-5217	WINDOW,INSIDE,IMPACT,IMP,SHORT	1	113	731-5217	WINDOW,INSIDE,IMPACT,IMP,SHORT	1	114	731-5217	WINDOW,INSIDE,IMPACT,IMP,SHORT	1	115	731-5217	WINDOW,INSIDE,IMPACT,IMP,SHORT	1	116	731-5217	WINDOW,INSIDE,IMPACT,IMP,SHORT	1				
	13	731-0235	SCREW,M8 X 1.25,75mm,BHC,HK	4	58	731-3323	STICKER,IMP,130 KG	1	112	731-5217	WINDOW,INSIDE,IMPACT,IMP,SHORT	1	113	731-5217	WINDOW,INSIDE,IMPACT,IMP,SHORT	1	114	731-5217	WINDOW,INSIDE,IMPACT,IMP,SHORT	1	115	731-5217	WINDOW,INSIDE,IMPACT,IMP,SHORT	1	116	731-5217	WINDOW,INSIDE,IMPACT,IMP,SHORT	1	117	731-5217	WINDOW,INSIDE,IMPACT,IMP,SHORT	1				
	14	731-0287	NUT,M8x1.25,NYLOCK	1	59	731-3324	WELD,ADD ON,SHORT,IMP	2	113	731-5217	WINDOW,INSIDE,IMPACT,IMP,SHORT	1	114	731-5217	WINDOW,INSIDE,IMPACT,IMP,SHORT	1	115	731-5217	WINDOW,INSIDE,IMPACT,IMP,SHORT	1	116	731-5217	WINDOW,INSIDE,IMPACT,IMP,SHORT	1	117	731-5217	WINDOW,INSIDE,IMPACT,IMP,SHORT	1	118	731-5217	WINDOW,INSIDE,IMPACT,IMP,SHORT	1				
	15	731-0335	STICKER, MADE IN CHINA, IP	1	60	731-3387	BELT GUIDE,63MM	1	114	731-5217	WINDOW,INSIDE,IMPACT,IMP,SHORT	1	115	731-5217	WINDOW,INSIDE,IMPACT,IMP,SHORT	1	116	731-5217	WINDOW,INSIDE,IMPACT,IMP,SHORT	1	117	731-5217	WINDOW,INSIDE,IMPACT,IMP,SHORT	1	118	731-5217	WINDOW,INSIDE,IMPACT,IMP,SHORT	1	119	731-5217	WINDOW,INSIDE,IMPACT,IMP,SHORT	1				
	16	731-0354	SCREW,M8 X 1.25,25MM,HHM,HE	6	61	731-3391	BELT CLAMP BODY	1	115	731-5217	WINDOW,INSIDE,IMPACT,IMP,SHORT	1	116	731-5217	WINDOW,INSIDE,IMPACT,IMP,SHORT	1	117	731-5217	WINDOW,INSIDE,IMPACT,IMP,SHORT	1	118	731-5217	WINDOW,INSIDE,IMPACT,IMP,SHORT	1	119	731-5217	WINDOW,INSIDE,IMPACT,IMP,SHORT	1	120	731-5217	WINDOW,INSIDE,IMPACT,IMP,SHORT	1				
	17	731-0355	WASHER,PLAIN,M8,NARROW	60	62	731-3392	PLATE,THREADED,BELT CLAMP	1	116	731-5217	WINDOW,INSIDE,IMPACT,IMP,SHORT	1	117	731-5217	WINDOW,INSIDE,IMPACT,IMP,SHORT	1	118	731-5217	WINDOW,INSIDE,IMPACT,IMP,SHORT	1	119	731-5217	WINDOW,INSIDE,IMPACT,IMP,SHORT	1	120	731-5217	WINDOW,INSIDE,IMPACT,IMP,SHORT	1	121	731-5217	WINDOW,INSIDE,IMPACT,IMP,SHORT	1				
	18	731-0357	WASHER,PLAIN,M12	2	63	731-3393	BELT CLAMP PLATE	2	117	731-5217	WINDOW,INSIDE,IMPACT,IMP,SHORT	1	118	731-5217	WINDOW,INSIDE,IMPACT,IMP,SHORT	1	119	731-5217	WINDOW,INSIDE,IMPACT,IMP,SHORT	1	120	731-5217	WINDOW,INSIDE,IMPACT,IMP,SHORT	1	121	731-5217	WINDOW,INSIDE,IMPACT,IMP,SHORT	1	122	731-5217	WINDOW,INSIDE,IMPACT,IMP,SHORT	1				
	19	731-0363	NUT,M10X1.5,NYLOC	4	64	731-3396	SHROUD CENTER SUPPORT	1	118	731-5217	WINDOW,INSIDE,IMPACT,IMP,SHORT	1	119	731-5217	WINDOW,INSIDE,IMPACT,IMP,SHORT	1	120	731-5217	WINDOW,INSIDE,IMPACT,IMP,SHORT	1	121	731-5217	WINDOW,INSIDE,IMPACT,IMP,SHORT	1	122	731-5217	WINDOW,INSIDE,IMPACT,IMP,SHORT	1	123	731-5217	WINDOW,INSIDE,IMPACT,IMP,SHORT	1				
	20	731-0365	NUT,M8 X 1.25,NYLOC JAM	23	65	731-3417	ASSY,WGT STK,130KG	1	119	731-5217	WINDOW,INSIDE,IMPACT,IMP,SHORT	1	120	731-5217	WINDOW,INSIDE,IMPACT,IMP,SHORT	1	121	731-5217	WINDOW,INSIDE,IMPACT,IMP,SHORT	1	122	731-5217	WINDOW,INSIDE,IMPACT,IMP,SHORT	1	123	731-5217	WINDOW,INSIDE,IMPACT,IMP,SHORT	1	124	731-5217	WINDOW,INSIDE,IMPACT,IMP,SHORT	1				
	21	731-0367	WASHER,PLAIN,M10	12	66	731-3521	SCREW,M8 X 1.25,105mm,BHC,HK,NP	4	120	731-5217	WINDOW,INSIDE,IMPACT,IMP,SHORT	1	121	731-5217	WINDOW,INSIDE,IMPACT,IMP,SHORT	1	122	731-5217	WINDOW,INSIDE,IMPACT,IMP,SHORT	1	123	731-5217	WINDOW,INSIDE,IMPACT,IMP,SHORT	1	124	731-5217	WINDOW,INSIDE,IMPACT,IMP,SHORT	1	125	731-5217	WINDOW,INSIDE,IMPACT,IMP,SHORT	1				
	22	731-0371	SCREW,M10 X 1.5,70MM,BHC,HK	2	67	731-3522	SCREW,M8 X 1.25,110mm,BHC,HK,NP	3	121	731-5217	WINDOW,INSIDE,IMPACT,IMP,SHORT	1	122	731-5217	WINDOW,INSIDE,IMPACT,IMP,SHORT	1	123	731-5217	WINDOW,INSIDE,IMPACT,IMP,SHORT	1	124	731-5217	WINDOW,INSIDE,IMPACT,IMP,SHORT	1	125	731-5217	WINDOW,INSIDE,IMPACT,IMP,SHORT	1	126	731-5217	WINDOW,INSIDE,IMPACT,IMP,SHORT	1				
	23	731-0373	WASHER,PLAIN,M6	10	68	731-3526	CLAMSHELL,44.5X 110 HS NO BREATHER	2	122	731-5217	WINDOW,INSIDE,IMPACT,IMP,SHORT	1	123	731-5217	WINDOW,INSIDE,IMPACT,IMP,SHORT	1	124	731-5217	WINDOW,INSIDE,IMPACT,IMP,SHORT	1	125	731-5217	WINDOW,INSIDE,IMPACT,IMP,SHORT	1	126	731-5217	WINDOW,INSIDE,IMPACT,IMP,SHORT	1	127	731-5217	WINDOW,INSIDE,IMPACT,IMP,SHORT	1				
	24	731-0379	SCREW,M8 X1.25,20mm,SHC,HK	2	69	731-3537	GUIDE RODE,Ø22MM X 1248MM	2	123	731-5217	WINDOW,INSIDE,IMPACT,IMP,SHORT	1	124	731-5217	WINDOW,INSIDE,IMPACT,IMP,SHORT	1	125	731-5217	WINDOW,INSIDE,IMPACT,IMP,SHORT	1	126	731-5217	WINDOW,INSIDE,IMPACT,IMP,SHORT	1	127	731-5217	WINDOW,INSIDE,IMPACT,IMP,SHORT	1	128	731-5217	WINDOW,INSIDE,IMPACT,IMP,SHORT	1				
	25	731-0381	HOUSING,LOGO,STARTRAC	1	70	731-3540	PIN,BELT CLAMP	1	124	731-5217	WINDOW,INSIDE,IMPACT,IMP,SHORT	1	125	731-5217	WINDOW,INSIDE,IMPACT,IMP,SHORT	1	126	731-5217	WINDOW,INSIDE,IMPACT,IMP,SHORT	1	127	731-5217	WINDOW,INSIDE,IMPACT,IMP,SHORT	1	128	731-5217	WINDOW,INSIDE,IMPACT,IMP,SHORT	1	129	731-5217	WINDOW,INSIDE,IMPACT,IMP,SHORT	1				
	26	731-0390	SCREW,M8 X 1.25,25mm,SHC,HK	3	71	731-3541	CLIP,BELT CLAMP PIN	2	125	731-5217	WINDOW,INSIDE,IMPACT,IMP,SHORT	1	126	731-5217	WINDOW,INSIDE,IMPACT,IMP,SHORT	1	127	731-5217	WINDOW,INSIDE,IMPACT,IMP,SHORT	1	128	731-5217	WINDOW,INSIDE,IMPACT,IMP,SHORT	1	129	731-5217	WINDOW,INSIDE,IMPACT,IMP,SHORT	1	130	731-5217	WINDOW,INSIDE,IMPACT,IMP,SHORT	1				
	27	731-0397	SCREW,M8 X 1.25,25mm,FHM,HK	2	72	731-3557	BOLT PLATE,FLAT,52X105 HS	1	126	731-5217	WINDOW,INSIDE,IMPACT,IMP,SHORT	1	127	731-5217	WINDOW,INSIDE,IMPACT,IMP,SHORT	1	128	731-5217	WINDOW,INSIDE,IMPACT,IMP,SHORT	1	129	731-5217	WINDOW,INSIDE,IMPACT,IMP,SHORT	1	130	731-5217	WINDOW,INSIDE,IMPACT,IMP,SHORT	1	131	731-5217	WINDOW,INSIDE,IMPACT,IMP,SHORT	1				
	28	731-0398	SCREW,M8 X 1.25,70mm,BHC,HK	4	73	731-3559	SCREW,M10 X 1.5,65MM,BHC,HK, NP	2	127	731-5217	WINDOW,INSIDE,IMPACT,IMP,SHORT	1	128	731-5217	WINDOW,INSIDE,IMPACT,IMP,SHORT	1	129	731-5217	WINDOW,INSIDE,IMPACT,IMP,SHORT	1	130	731-5217	WINDOW,INSIDE,IMPACT,IMP,SHORT	1	131	731-5217	WINDOW,INSIDE,IMPACT,IMP,SHORT	1	132	731-5217	WINDOW,INSIDE,IMPACT,IMP,SHORT	1				
	29	731-0512	STICKER,WARNING,PINCH	4	74	731-3773	PLATE, BELT CLAMP, IMP	2	128	731-5217	WINDOW,INSIDE,IMPACT,IMP,SHORT	1	129	731-5217	WINDOW,INSIDE,IMPACT,IMP,SHORT	1	130	731-5217	WINDOW,INSIDE,IMPACT,IMP,SHORT	1	131	731-5217	WINDOW,INSIDE,IMPACT,IMP,SHORT	1	132	731-5217	WINDOW,INSIDE,IMPACT,IMP,SHORT	1	133	731-5217	WINDOW,INSIDE,IMPACT,IMP,SHORT	1				
	30	731-0513	STICKER,STAR TRAC,DECO.45MMX191MM	1	75	731-3792-00XX	ASSY,UPHOLSTERY,SEAT	1	129	731-5217	WINDOW,INSIDE,IMPACT,IMP,SHORT	1	130	731-5217	WINDOW,INSIDE,IMPACT,IMP,SHORT	1	131	731-5217	WINDOW,INSIDE,IMPACT,IMP,SHORT	1	132	731-5217	WINDOW,INSIDE,IMPACT,IMP,SHORT	1	133	731-5217	WINDOW,INSIDE,IMPACT,IMP,SHORT	1	134	731-5217	WINDOW,INSIDE,IMPACT,IMP,SHORT	1				
	31	731-0532	SCREW,M8 X 1.25,12MM,HHM,HE	3	76	731-3796	ASSY,STOP,MOUNT,ADD ON,IMP	1	130	731-5217	WINDOW,INSIDE,IMPACT,IMP,SHORT	1	131	731-5217	WINDOW,INSIDE,IMPACT,IMP,SHORT	1	132	731-5217	WINDOW,INSIDE,IMPACT,IMP,SHORT	1	133	731-5217	WINDOW,INSIDE,IMPACT,IMP,SHORT	1	134	731-5217	WINDOW,INSIDE,IMPACT,IMP,SHORT	1	135	731-5217	WINDOW,INSIDE,IMPACT,IMP,SHORT	1				
	32	731-0582	SETSCREW, M8 X 1.25, 10mm, CUP	2	77	731-3802	HANDLE ASSY,SEAT ADJUST,RATCHET	1	131	731-5217	WINDOW,INSIDE,IMPACT,IMP,SHORT	1	132	731-5217	WINDOW,INSIDE,IMPACT,IMP,SHORT	1	133	731-5217	WINDOW,INSIDE,IMPACT,IMP,SHORT	1	134	731-5217	WINDOW,INSIDE,IMPACT,IMP,SHORT	1	135	731-5217	WINDOW,INSIDE,IMPACT,IMP,SHORT	1	136	731-5217	WINDOW,INSIDE,IMPACT,IMP,SHORT	1				
	33	731-0583	STICKER, SERIAL NUMBER, IP	1	78	731-3805	SPRING,O.D 12mm,L 38MM, 1N/MM RATE	1	132	731-5217	WINDOW,INSIDE,IMPACT,IMP,SHORT	1	133	731-5217	WINDOW,INSIDE,IMPACT,IMP,SHORT	1	134	731-5217	WINDOW,INSIDE,IMPACT,IMP,SHORT	1	135	731-5217	WINDOW,INSIDE,IMPACT,IMP,SHORT	1	136	731-5217	WINDOW,INSIDE,IMPACT,IMP,SHORT	1	137	731-5217	WINDOW,INSIDE,IMPACT,IMP,SHORT	1				
	34	731-0637	RING,BEAUTY,ADJ,PAD	1	79	731-3833	TUBE,BELT GUIDE	1	133	731-5217	WINDOW,INSIDE,IMPACT,IMP,SHORT	1	134	731-5217	WINDOW,INSIDE,IMPACT,IMP,SHORT	1	135	731																		

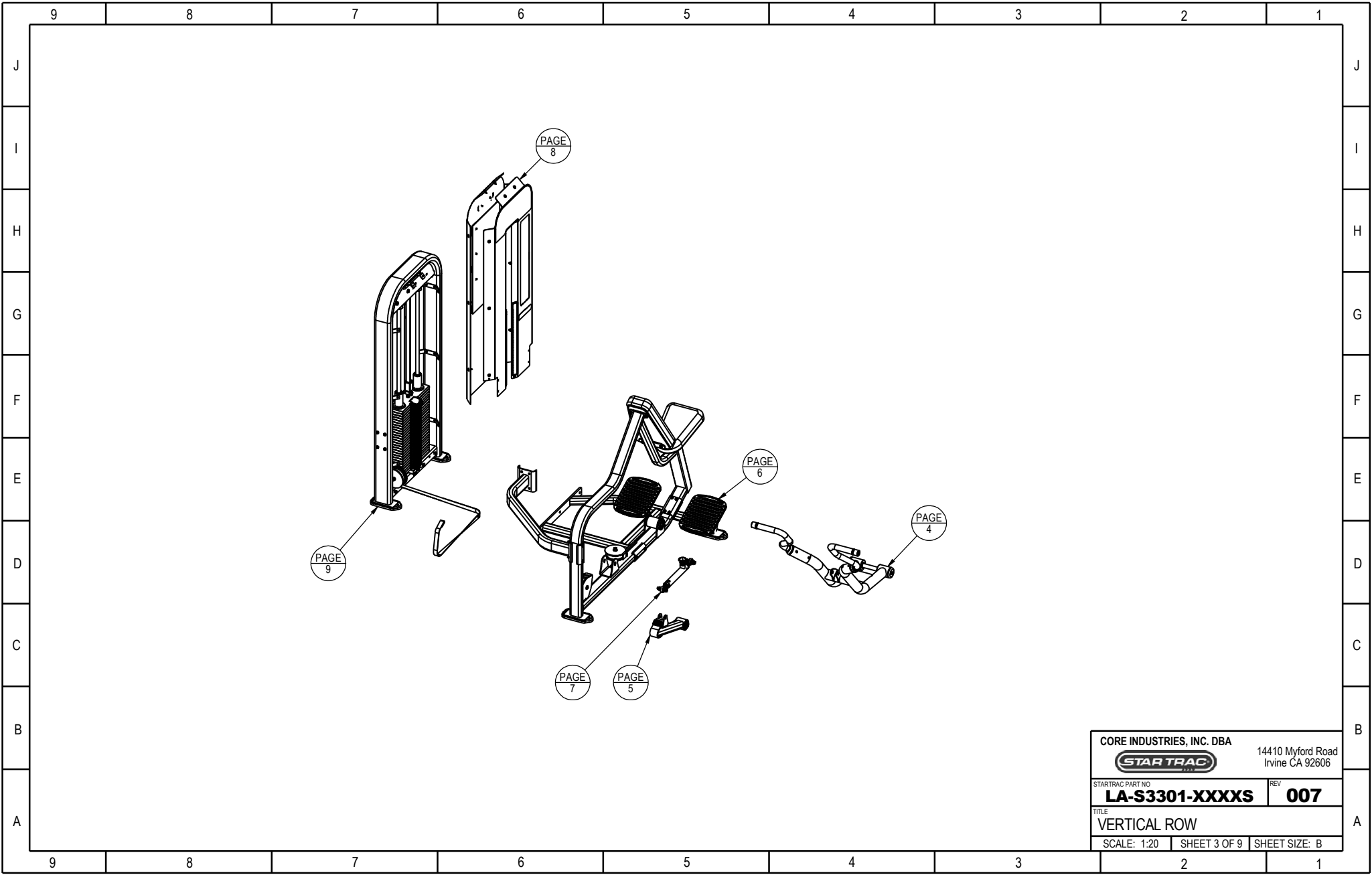

CORE INDUSTRIES, INC. DBA		14410 Myford Road
		Irvine CA 92606
STARTRAC PART NO	REV	
<b>LA-S3301-XXXXS</b>	<b>007</b>	
TITLE		
VERTICAL ROW		
SCALE: 1:20	SHEET 3 OF 9	SHEET SIZE: B

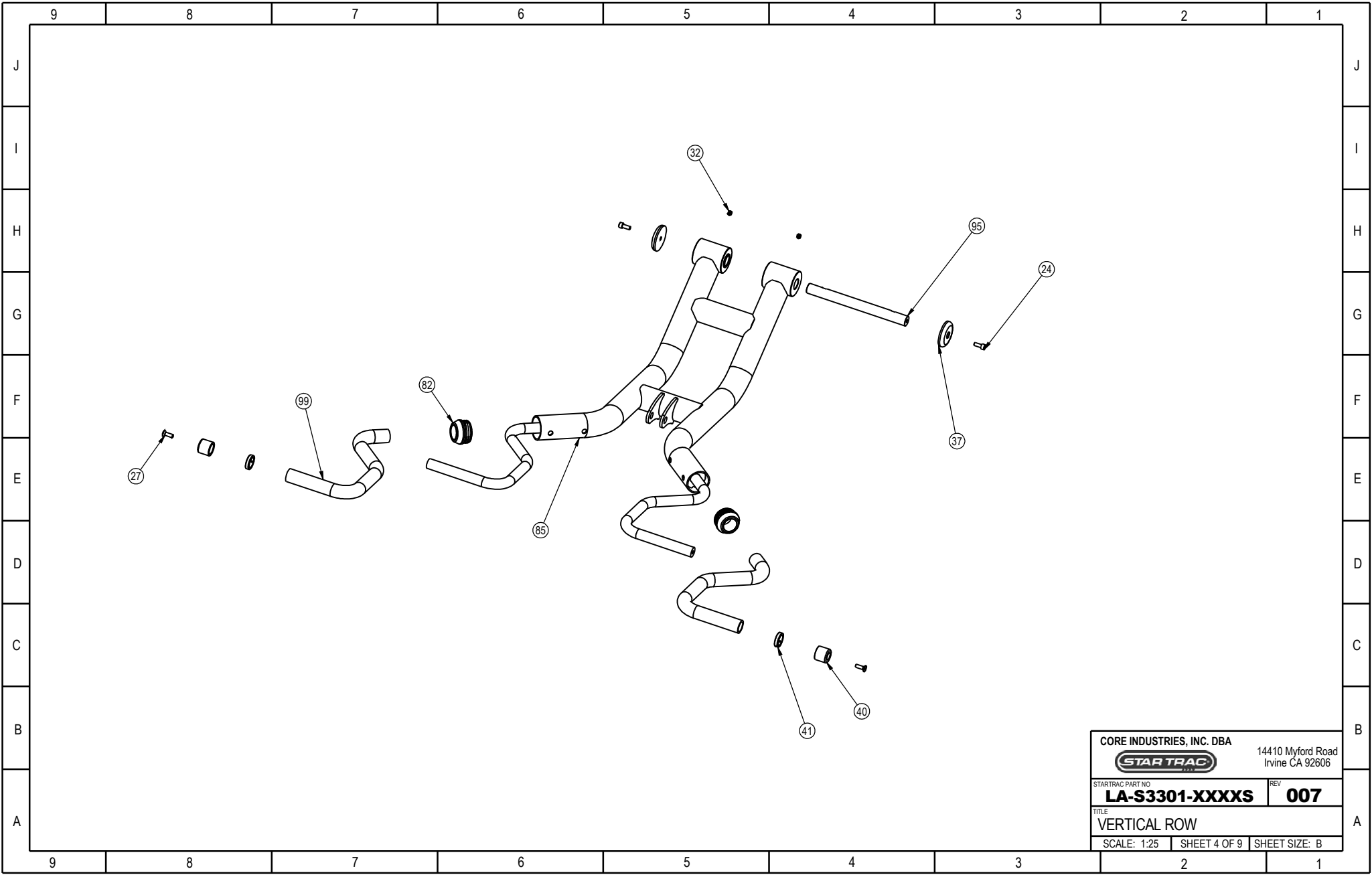

CORE INDUSTRIES, INC. DBA		14410 Myford Road
		Irvine CA 92606
STARTRAC PART NO	REV	
<b>LA-S3301-XXXXS</b>	<b>007</b>	
TITLE		
VERTICAL ROW		
SCALE: 1:25	SHEET 4 OF 9	SHEET SIZE: B

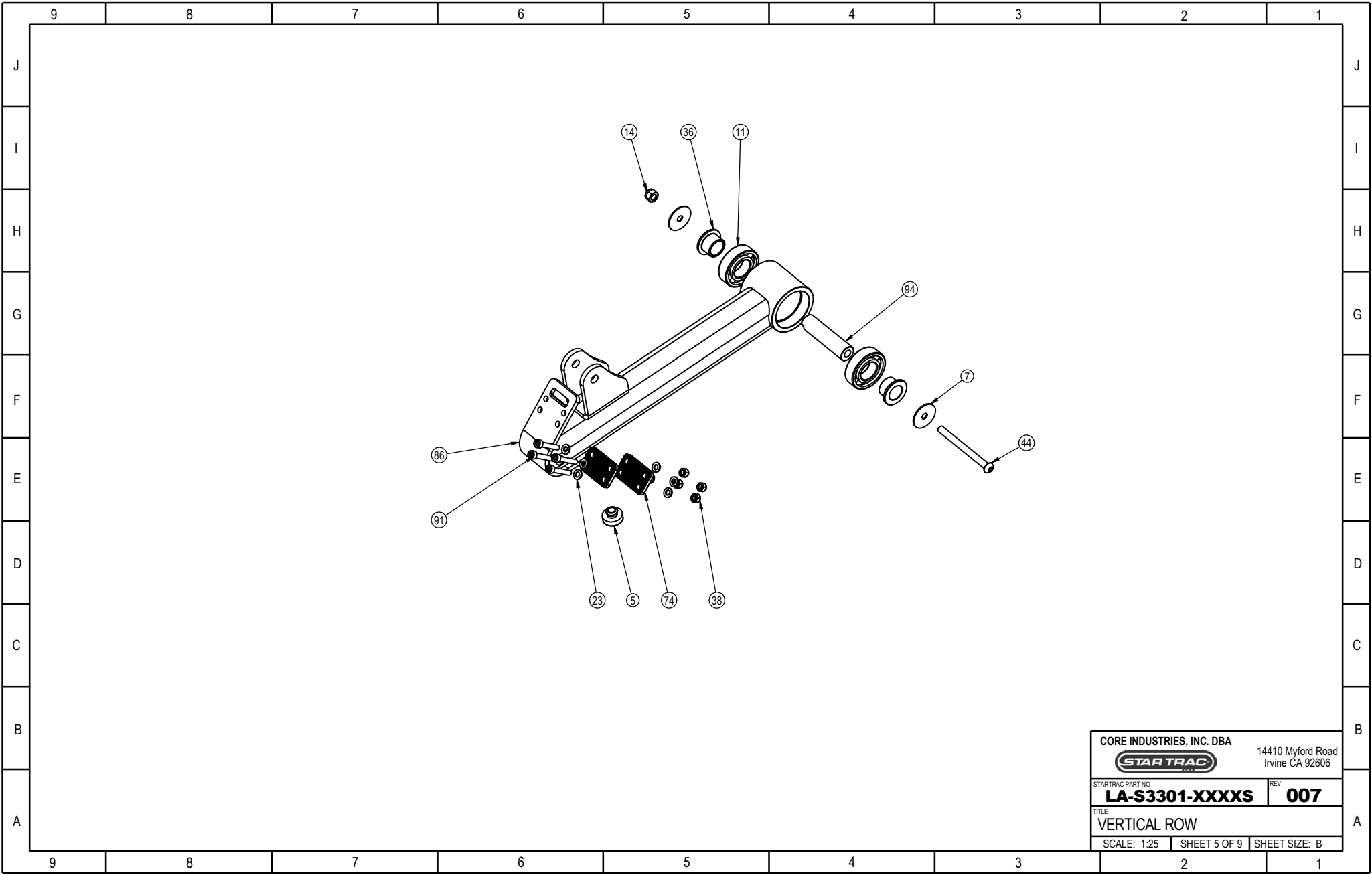

CORE INDUSTRIES, INC. DBA		14410 Myford Road Irvine CA 92606
STARTRAC PART NO	<b>LA-S3301-XXXXS</b>	REV <b>007</b>
TITLE <b>VERTICAL ROW</b>		
SCALE: 1:25	SHEET 5 OF 9	SHEET SIZE: B

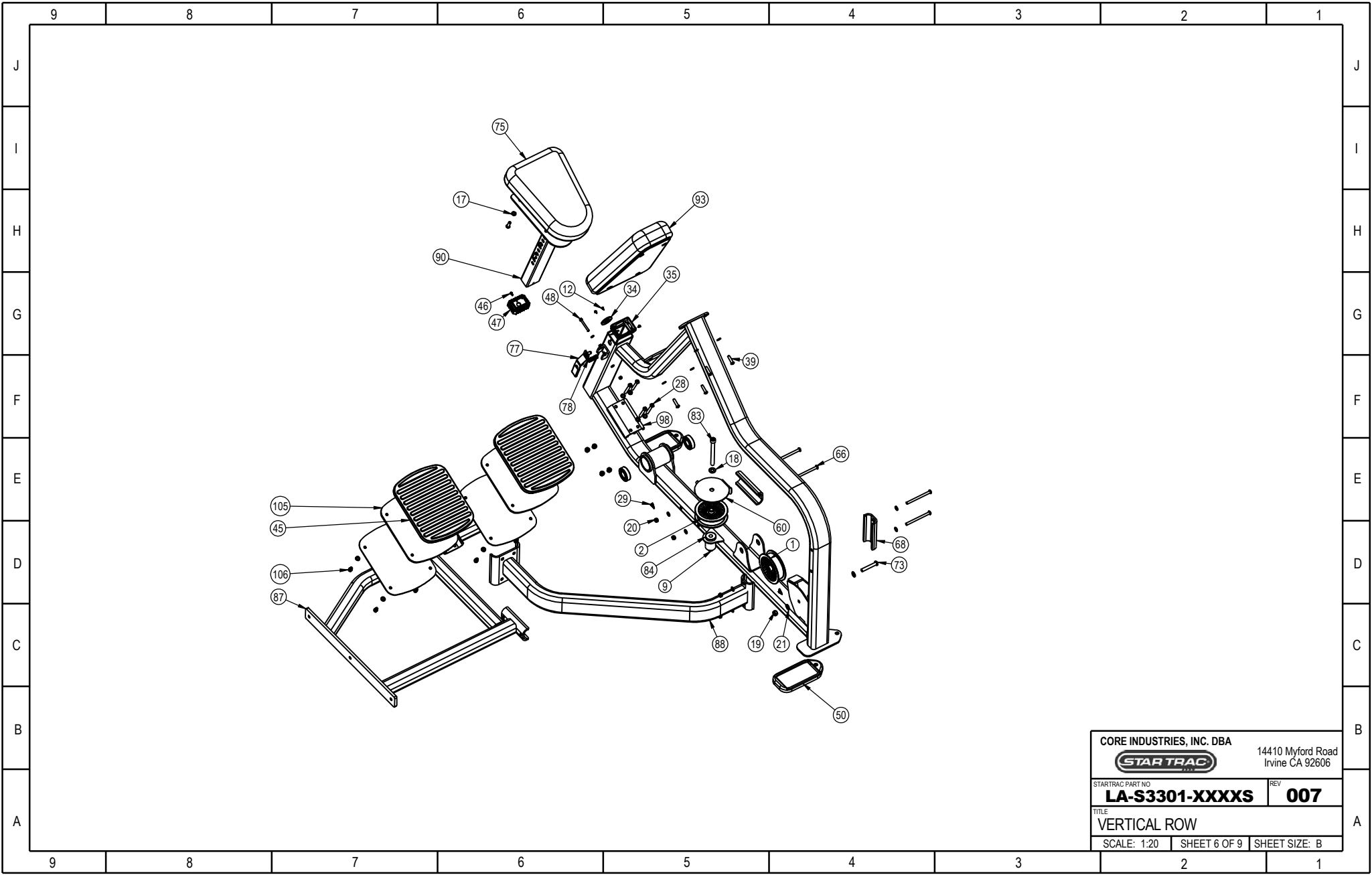

CORE INDUSTRIES, INC. DBA		14410 Myford Road Irvine CA 92606	
STARTRAC PART NO	<b>LA-S3301-XXXXS</b>	REV	<b>007</b>
TITLE			
<b>VERTICAL ROW</b>			
SCALE: 1:20	SHEET 6 OF 9	SHEET SIZE: B	

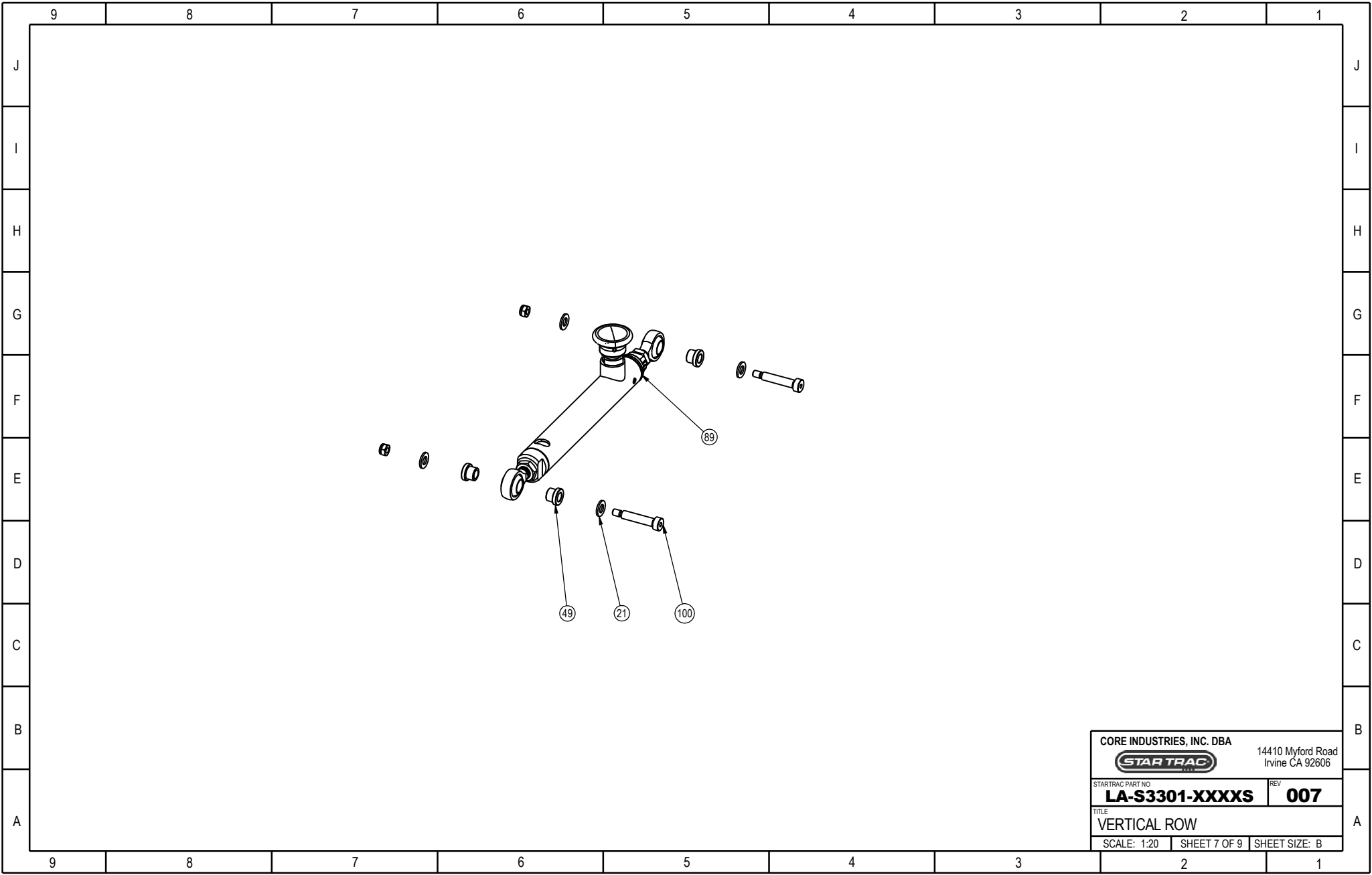

CORE INDUSTRIES, INC. DBA		14410 Myford Road
		Irvine CA 92606
STARTRAC PART NO	REV	
<b>LA-S3301-XXXXS</b>	<b>007</b>	
TITLE		
VERTICAL ROW		
SCALE: 1:20	SHEET 7 OF 9	SHEET SIZE: B

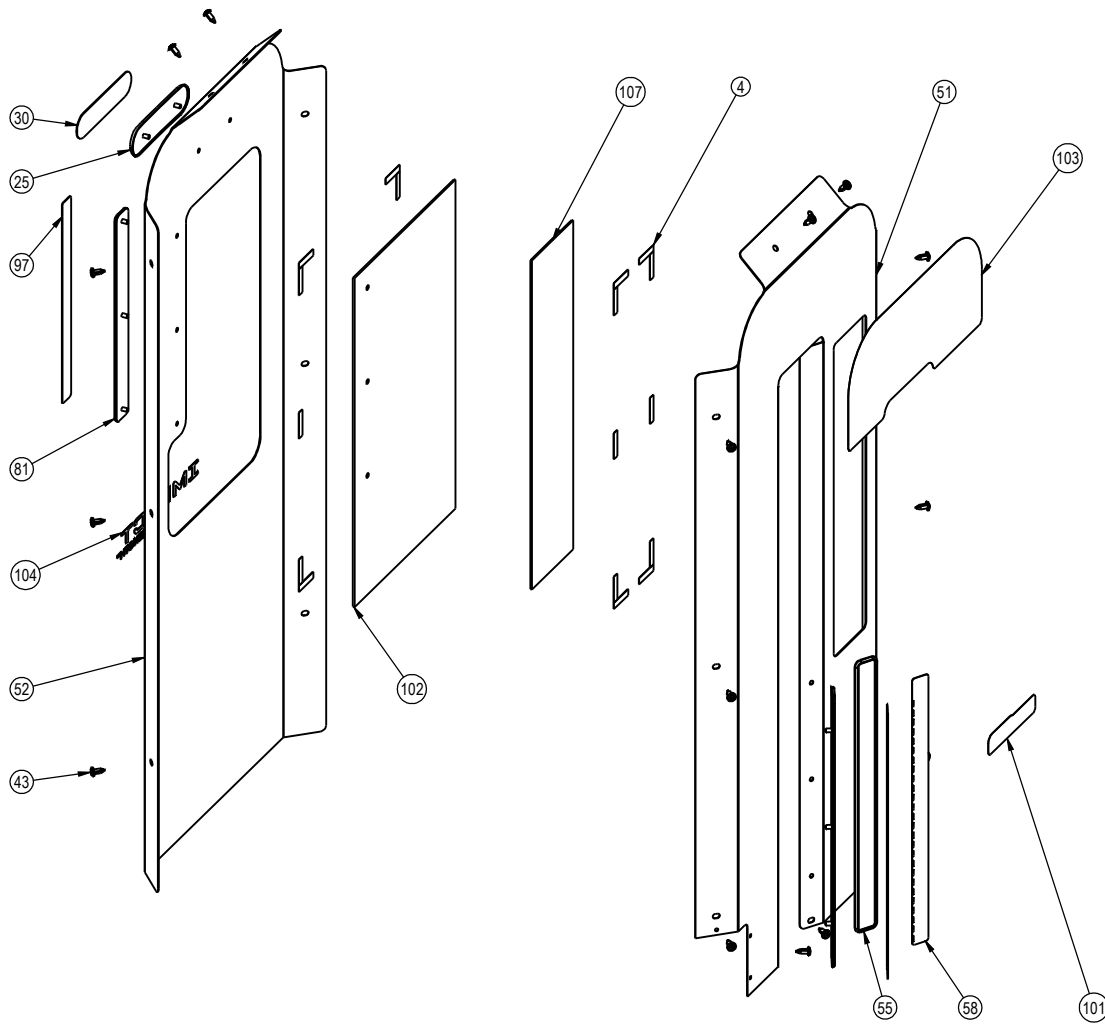

CORE INDUSTRIES, INC. DBA		14410 Myford Road
		Irvine CA 92606
STARTRAC PART NO	REV	
<b>LA-S3301-XXXXS</b>	<b>007</b>	
TITLE		
VERTICAL ROW		
SCALE: 1:20	SHEET 8 OF 9	SHEET SIZE: B



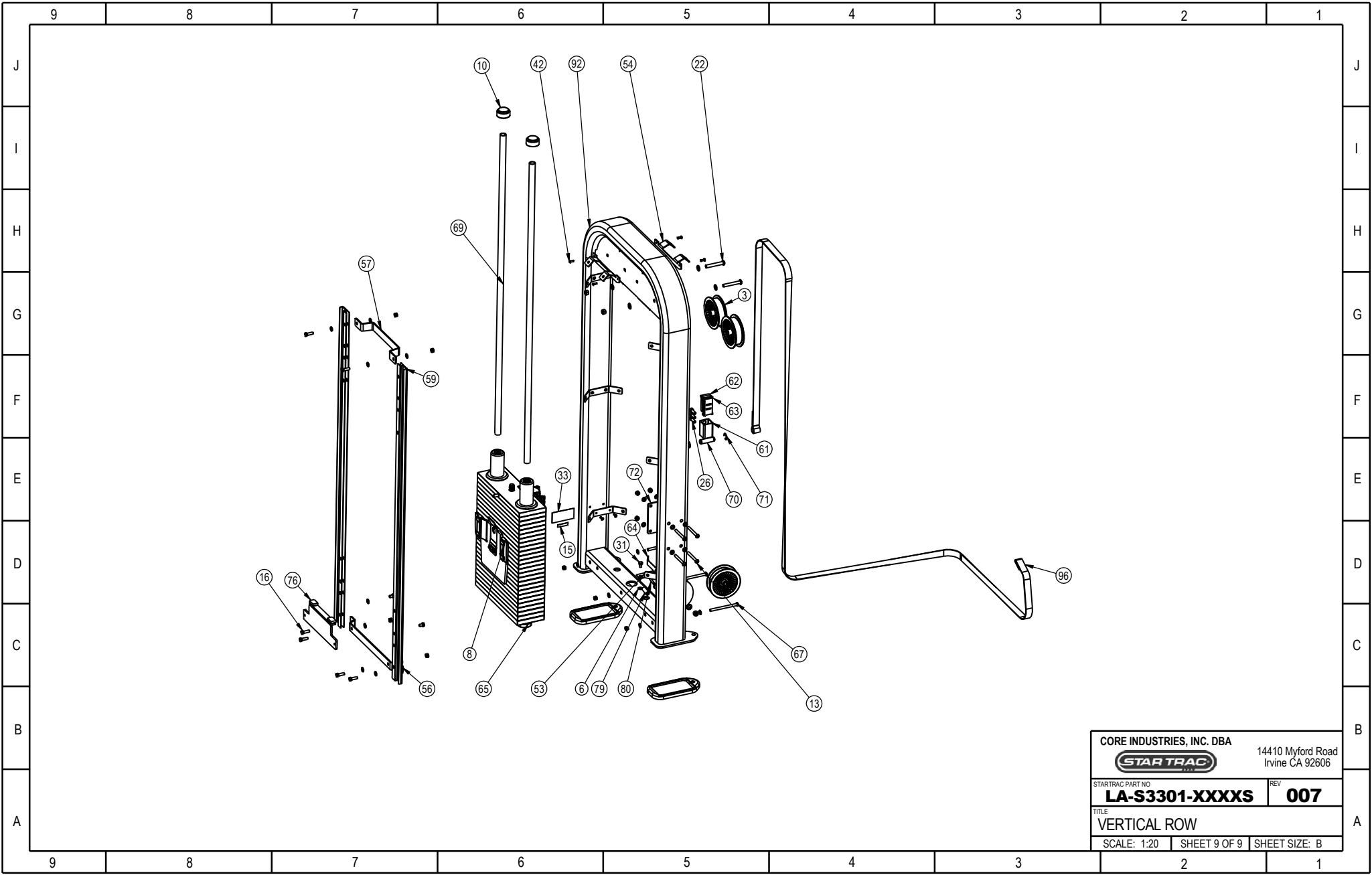

CORE INDUSTRIES, INC. DBA		14410 Myford Road Irvine CA 92606	
STARTRAC PART NO	<b>LA-S3301-XXXXS</b>	REV	<b>007</b>
TITLE <b>VERTICAL ROW</b>			
SCALE: 1:20	SHEET 9 OF 9	SHEET SIZE: B	