

REVISION HISTORY				
REV	DATE	DESCRIPTION	ECO	BY
A	11/1/2011	RELEASED FOR PRODUCTION	13676	KEY

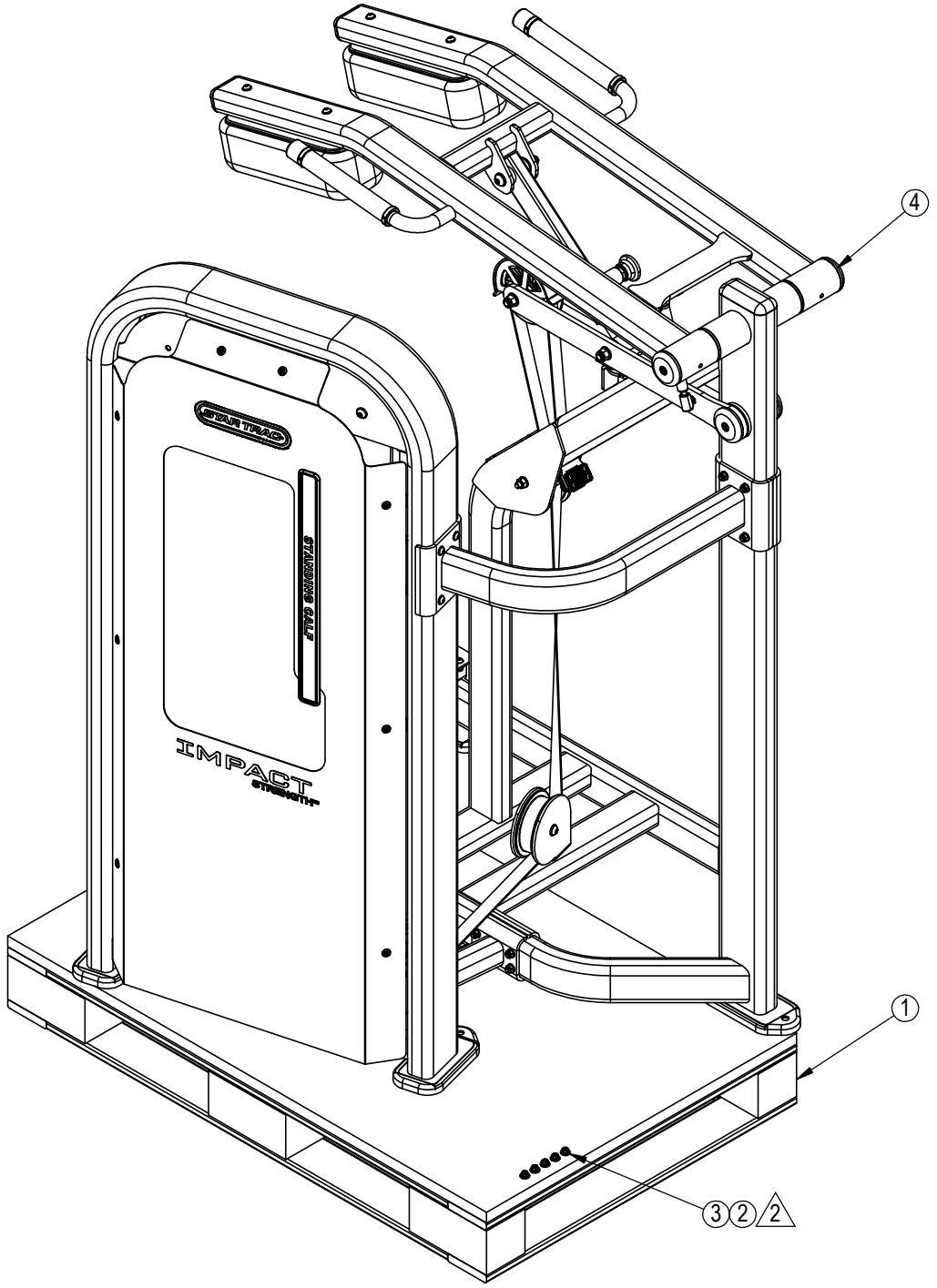

ITEM NO.	PART NUMBER	DESCRIPTION	QTY.
1	731-0178	PALLET, 765 x 1180 x 152	1
2	731-0256	SCREW, M6, 25mm, W, HE, ZP	5
3	731-0294	WASHER, M8, NYLON	5
4	LA-S1309-XXXXS	LA, SSS, STANDING CALF	1

**DOCUMENT STATUS:**

NOTICE OF PROPRIETARY INFORMATION  
THIS DOCUMENT SHALL NOT BE REPRODUCED NOR SHALL THE INFORMATION CONTAINED HEREIN BE USED BY OR DISCLOSED TO OTHER EXCEPT AS EXPRESSLY AUTHORIZED BY CORE INDUSTRIES, INC., D.B.A. STAR TRAC.

CLASS OF WORK	UNLESS OTHERWISE SPECIFIED DIMS ARE IN mm. TOLERANCES FOR MEASURE OF LENGTH ARE:							ANGLES = ±2°		
	0.5 to 3	>3 to 6	>6 to 30	>30 to 120	>120 to 400	>400 to 1000	>1000 to 2000	>2000		
FINE	±0.05	±0.05	±0.1	±0.15	±0.2	±0.3	±0.5	----		
MEDIUM	±0.1	±0.1	±0.2	±0.3	±0.5	±0.8	±1.2	±2		
COARSE	±0.2	±0.3	±0.5	±0.8	±1.2	±2	±3	±4		
VERY COARSE	----	±0.5	±1	±1.5	±2.5	±4	±6	±8		

<b>MATERIAL</b> SEE BOM	
<b>FINISH</b> N/A	
VENDOR: <b>N/A</b>	
P/N: <b>N/A</b>	

THIRD ANGLE PROJECTION		
DRAWN	INITIAL	DATE
CHECKED	KEY	8/23/12
APPROVED		

**CORE INDUSTRIES, INC. DBA**  
 14410 Myford Road  
Irvine CA 92606

STARTRAC PART NO: **9LA-S1309-XXXXS** REV: **A**

TITLE: **LA, SSS, STANDING CALF**

SCALE: 1:33.3 SHEET 1 OF 1 SHEET SIZE: B

- NOTES:
- PLACE SHIPPING LABELS ON PACKAGED UNIT BEFORE SHRINK WRAPPING.
  - USE ITEM 2,3 TO SECURE ITEM 4 TO PALLET (ITEM 1), PLACING ITEM 3 AGAINST POWDERCOAT OF ITEM 4.
  - ITEM 4 NOT SHOWN IN PACKAGED CONFIGURATION.