

REVISIONS			
REV.	DATE	DESCRIPTION	BY
A	7/29/2008	RELEASE FOR PRODUCTION	SLS

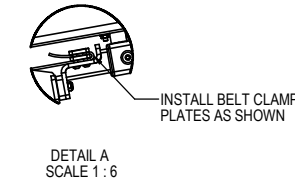
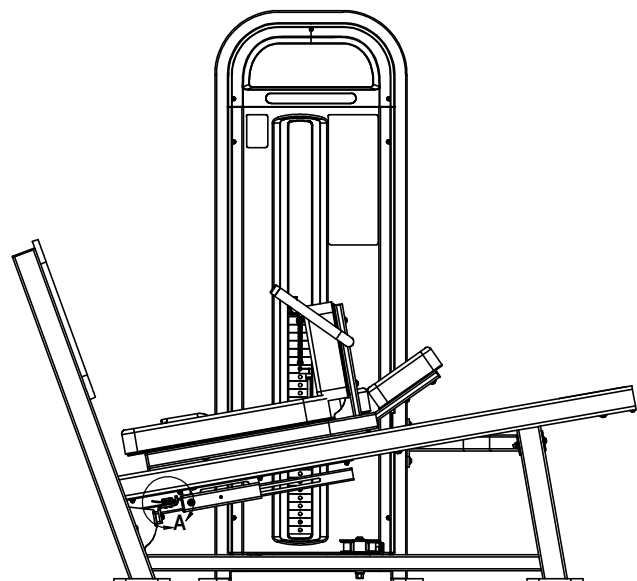
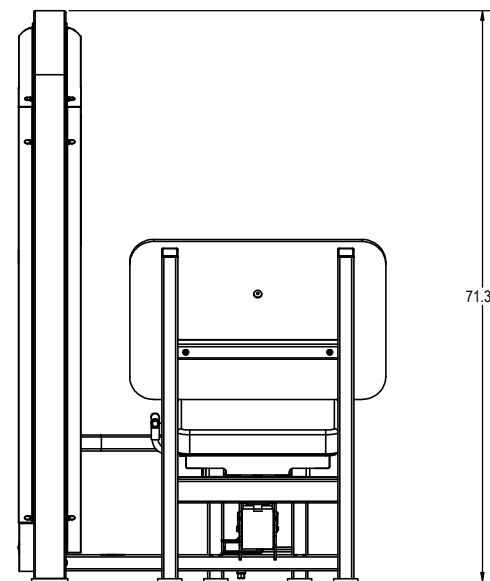
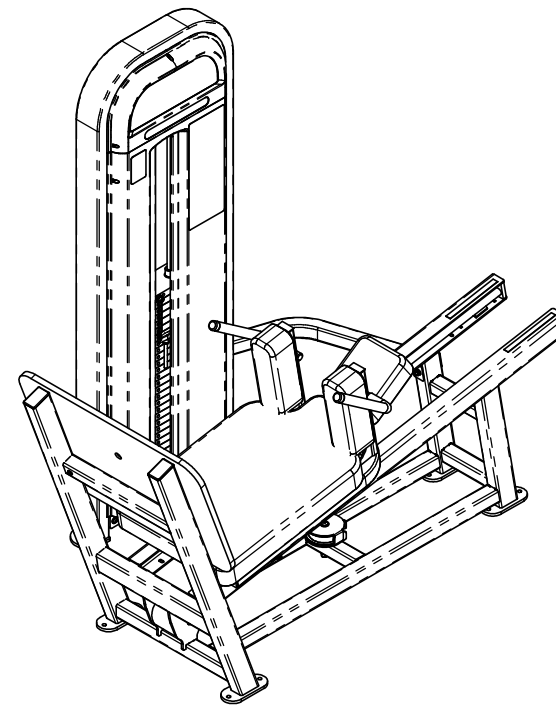
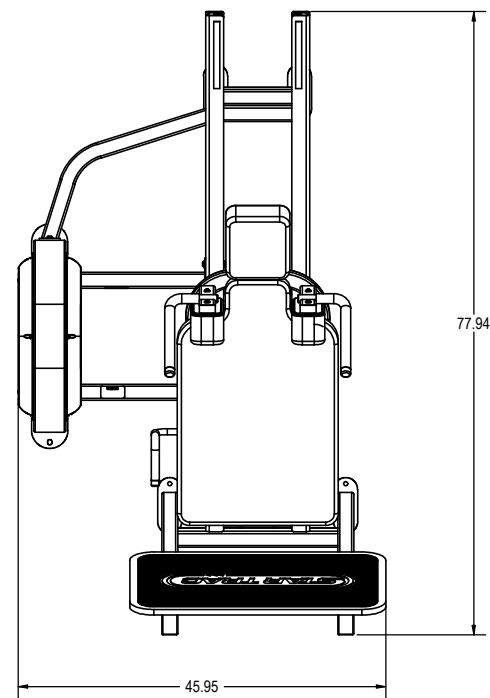

ITEM NO.	PART NUMBER	DESCRIPTION	QTY.
1	3211-0223	ASSY, WELD, MAIN FRAME, S1302	1
2	3211-0217	ASSY, WELD, WT STACK CONN, LOW	1
3	4900-0129	LINEAR SHAFT, 1" X 60	2
4	2120-0379	STANDOFF, 2", ALUMINUM	6
5	4900-0441	PULLEY BELT 4.75D, 1.2B, 1.5W, MOLDED	1
6	3211-0226	ASSY, WELD, WGT FRAME, LEG PRESS	1
7	4900-0562	PULLEY BELT 3.75D, 3.8B, 1.5W, MOLDED	1
8	2400-0025	STEP, RUBBER, 32X21, U-0065	1
9	2120-4053	PLATE, FLOOR GUARD	1
10	4900-0001	STOP, RED	1
11	2120-4052	STOP PLATE, LINEAR SHAFT	2
12	2130-0066	COVER, PULLEY, 5"	2
13	3211-0218	ASSY, WELD, WT STACK CONN, SIDE	1
14	4500-0029	NUT, NYLOC, JAM, 3/8-16, Z	14
15	4600-0009	WASHER, SAE, 3/8-16, Z	39
16	3211-0219	ASSY, WELD, ADJUST HANDLE	1
17	2120-4084	ROM ADJUST ARM, S1302	1
18	4600-0008	Nut, JAM, 1/4-20, Z	9
19	4600-0006	FLAT WASHER, 1/4 Z	10
20	4230-0095	BHSCS, 3/8-24 X 1 1/2, BRIGHT, Z	6
21	4230-0066	BHSCS, 3/8-16 X 3/4, BRIGHT, Z	1
22	3211-0214	ASSY, WELD, TROLLEY, 18 INCH	1
23	2210-0009	BUSHING, SEAT POST	1
24	3211-0215	ASSY, WELD, ROM, LEG PRESS	1
25	2120-4055	PIN, ROM RELEASE, .50 DIA	1
26	4900-0036	BEARING, FLANGE, 750B X 750H	2
27	4230-0060	BHSCS, 3/8-16 X 2 3/4, BRIGHT, Z	4
28	3500-0055	ASSY, UPHOLSTERY, 12x4, FL-108-B	2
29	3500-0127	ASSY, UPH, BACK REST, S1302	1
30	3211-0225	ASSY, WELD, BACK REST, S1302	1
31	3500-0091	ASSY, UPH, 9.5 X 8, FL-10	1
32	4900-0044	Pulley, Belt, 5.0d x 3.8b x 3.88w	1
33	2120-0296	RACE, INNER, 1 X 4 1/8	1
34	4900-0140	RING, RETAIN, 1" EXT, 5100-100	2
35	4230-0096	3/8-16 X 5, BRIGHT, Z	1
36	4900-0575	CARRIAGE SCREW, 1/4-20 X .75	8
37	4900-0118	BEARING, ROLLER, 1", L16 OPEN	4
38	4900-0629	PIN, SPRING, 1/8 X 3/8	4
39	4900-0297	LINK, CHAIN, #40, PL-170	1
40	2120-4081	BELT CLAMP, 1.25 x 2.88 X .25, 27 THRU	1
41	2120-4082	BELT CLAMP, 1.25 x 2.88 X .25, 1/4-20 TAP	1
42	4230-0047	BHSCS, 1/4-20 X 1, BRIGHT, Z	4
43	4600-0001	BELT, MECTROL, SPOOL	183 IN
44	4900-0087	CAP, BLACK, 2 X 3	2
45	4900-0085	PLASTIC CAP	3
46	4230-0100	BHSCS, 5/16-18 X 3.0, BRIGHT, Z	3
47	4230-0099	BHSCS, 5/16-18 X 2.0, BRIGHT, Z	6
48	4600-0007	WASHER, SAE, 5/16, Z	13
49	4230-0076	BHSCS, 1/2-13 X 4 3/4, BRIGHT, Z	1
50	4600-0008	WASHER, SAE, 1/2, Z	2
51	4500-0012	NUT, HEX, JAM, 1/2-13, Z	1
52	4230-0056	BHSCS, 3/8 X 3, BRIGHT, Z	5
53	4230-0053	BHSCS, 3/8-16 X 4, BRIGHT, Z	4
54	4230-0080	BHSCS, 5/16-18 X 2 3/4, BRIGHT, Z	2
55	4230-0098	BHSCS, 5/16-18 X 3/4, BRIGHT, Z	2
56	2120-3402	Ø5/16 ID X 1 1/2 HOLLOW ROD	1
57	4230-0097	BHSCS, 1/4-20, 2.5, BLK, Z	1
58	4230-0051	BHSCS, 3/8-16 X 2 1/2, BRIGHT, Z	2
59	3310-0124	ASSY, W-STK, 15LB/405LBS, BELT, TALL	1
60	2130-0064	PLATE, KICK PLATE	1
61	2120-3553	SHRD, MOD FRONT, LYING LEG PRESS, PR-S1302	1
62	2210-0001	SHROUD, UPPER, PRO	2
63	2210-0004	SHROUD, LOWER, LONG, OUTSIDE, PRO	1
64	4900-0440	PULLEY BELT 4.75D, 3.8B, 1.5W, MOLDED	2
65	4230-0057	BHSCS, 3/8 X 2 1/4, BRIGHT, Z	2
66	4500-0046	U-NUT, #8, PANEL, 025-125	14
67	4161-0074	SCREW, #8-18x1-1/2, PHT-AB, PH, CS	14
68	4230-0005	BHSCS, 1/4-20 X 1/2	2
69	4500-0048	U-NUT, 1/4-20 EDGE, 531, 025-150	2
70	5230-0024	LABEL, NAME LEG PRESS	2
71	5230-0008	LOGO, STAR TRAC, IMPACT, TOP SHROUD	2
72	5230-0009	LOGO, IMPACT, LOWER SHROUD	1
73	5230-0023	LABEL, SAFETY, MAIN WARNING, IMPACT	1
74	5210-0074	PLAC, IMPACT, PR-S1302, LYING LEG PRESS	1
75	2130-0069	BRACKET, MOUNT, KICK PLATE, IMPACT	2
76	5240-0014	Label, Instructional, 1-9 Strip	1
77	5220-0001	LABEL, SAFETY, KEEP HANDS, LARGE	2
78	5290-0001	SERIAL NUMBER	1
79	5220-0005	LABEL, SAFETY, SECURE TO FLOOR	1
80	4900-0065	CAP, HANDLE, 3/4"	1
81	1400-0006	TUBE, ROUND, 3/4" RUBBER, BLK	8 IN
82	4230-0001	SSS, 10-32 X 1/8, BLK	6
83	4900-0005	CAP, HANDLE, 1", CHROME	2
84	1400-0001	Tube, Round, 1", Rubber, Blk	28 IN
85	4900-0578	HEX, CAP, PULL PIN	1
86	4900-0579	SPRING, PULL PIN	1
87	4500-0016	NUT, NYLOC, 5/16-18, NE, Z	2
88	4900-UPHX	UPHOLSTERY, TBD	1.75 LN. YD.
89	4900-PNTX	POWDER COAT, TBD	2.25 LB

- NOTES:
1. INTERPRET DRAWING PER ASME Y14.5M-1994.
  2. IF APPLICABLE, CRITICAL DIMENSIONS LABELED.
  3. ALL HARDWARE IS KITTED PER 3700-0358
  4. ALL UPHOLSTERY IS KITTED PER 3700-0361
  5. EST GROSS WT. 620 LBS.

**DOCUMENT STATUS:**

**RELEASED**

UNLESS OTHERWISE SPECIFIED DIMENSIONS ARE IN INCHES. TOLERANCES ARE:  
 DECIMALS .015  
 FRACTIONS 1/32"  
 ANGLES .015"  
 HOLE POSITION .010"  
 HOLE DIA .010"

THIRD ANGLE PROJECTION

MATERIAL SEE BOM

FINISH N/A  
 VENDOR N/A  
 P/N: N/A

UNLESS OTHERWISE SPECIFIED DIMENSIONS ARE IN INCHES. TOLERANCES ARE:  
 DECIMALS .015  
 FRACTIONS 1/32"  
 ANGLES .015"  
 HOLE POSITION .010"  
 HOLE DIA .010"

**UNISEN, INC. DBA STAR TRAC** 14410 Myford Road  
 Irvine CA 92606

DRAWN JML DATE 7/29/08  
 CHECKED  
 APPROVED  
 U.O.M. INCH  
 SCALE: 1:12 SHEET 1 OF 2 SHEET SIZE: D

