

9 8 7 6 5 4 3 2 1

- NOTES:
- REFER TO FILE 7410-2066.AI FOR ART WORK.
  - PACKAGING TO COMPLY WITH TRANSPORTATION TEST PER ISTA PROJECT 2B (BASIC REQUIREMENTS: ATMOSPHERIC CONDITIONING, COMPRESSION, FIXED DISPLACEMENT OR RANDOM VIBRATION AND SHOCK TESTING).
  - THE FOLLOWING INFORMATION MUST BE INCLUDED IN THE CONTROL LABEL:
    - SERIES AND MODEL IDENTIFIER
    - SKU NUMBER
    - SKU BAR CODE
    - SERIAL NUMBER
    - SERIAL NUMBER BAR CODE
    - A STATEMENT FOR THE MANUFACTURING LOCATION.

| REVISION HISTORY |          |                    |       |    |
|------------------|----------|--------------------|-------|----|
| REV              | DATE     | DESCRIPTION        | ECO   | BY |
| A                | 08-08-07 | PRODUCTION RELEASE | 11686 | DN |

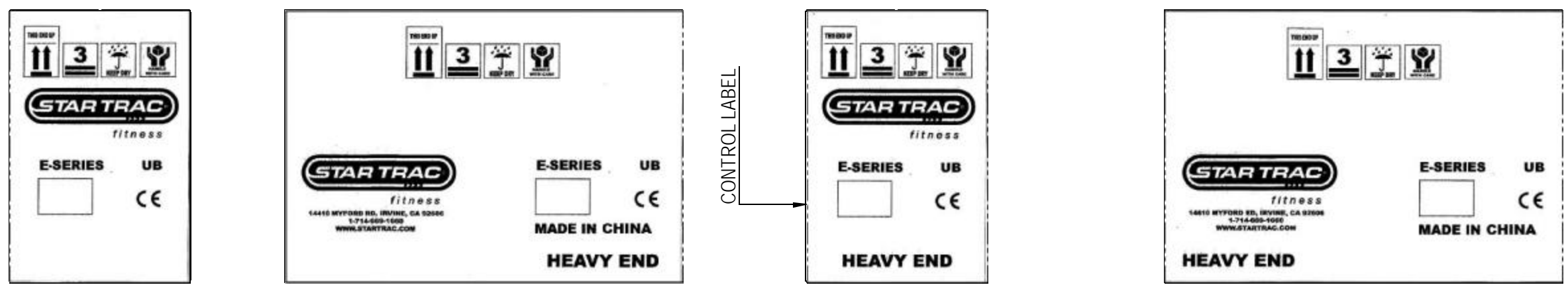
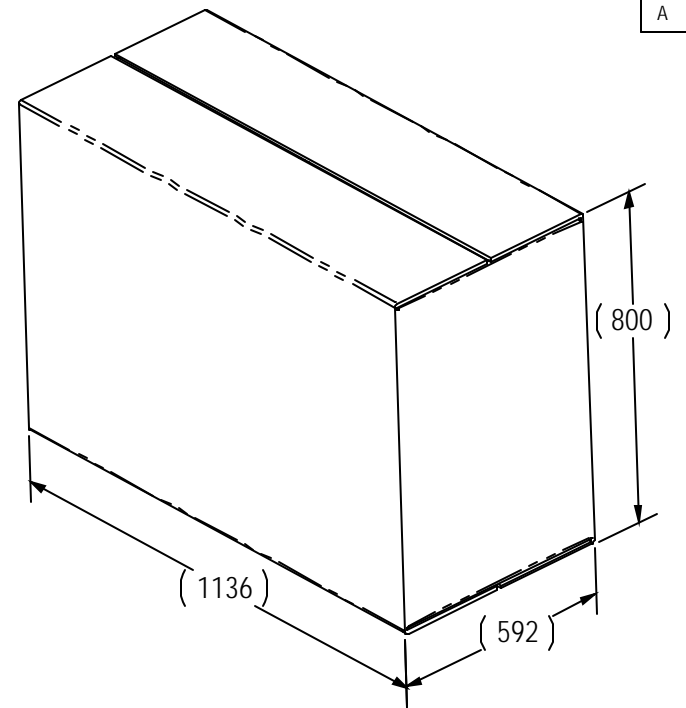

NOTICE OF PROPRIETARY INFORMATION  
 THIS DOCUMENT SHALL NOT BE REPRODUCED NOR SHALL THE INFORMATION CONTAINED HEREIN BE USED BY OR DISCLOSED TO OTHER EXCEPT AS EXPRESSLY AUTHORIZED BY UNISEN INC. D.B.A. STAR TRAC.

**DOCUMENT STATUS:  
 RELEASE**

| CLASS OF WORK | UNLESS OTHERWISE SPECIFIED DIMS ARE IN mm. TOLERANCES FOR MEASURE OF LENGTH ARE: |         |          |            |             |              |               |       |
|---------------|--|---------|----------|------------|-------------|--------------|---------------|-------|
|               | 0.5 to 3   | >3 to 6 | >6 to 30 | >30 to 120 | >120 to 400 | >400 to 1000 | >1000 to 2000 | >2000 |
| FINE          | ±0.05  | ±0.05   | ±0.1     | ±0.15      | ±0.2        | ±0.3         | ±0.5          | ----- |
| MEDIUM        | ±0.1   | ±0.1    | ±0.2     | ±0.3       | ±0.5        | ±0.8         | ±1.2          | ±2    |
| COARSE        | ±0.2   | ±0.3    | ±0.5     | ±0.8       | ±1.2        | ±2           | ±3            | ±4    |
| VERY COARSE   | -----  | ±0.5    | ±1       | ±1.5       | ±2.5        | ±4           | ±6            | ±8    |

**MATERIAL**  
 CORRUGATED CARDBOARD

**FINISH**  
 SEE NOTES

VENDOR: \_\_\_\_\_ P/N: \_\_\_\_\_

| THIRD ANGLE PROJECTION |         |          |
|------------------------|---------|----------|
|                        | INITIAL | DATE     |
| DRAWN                  | DN      | 07/11/07 |
| CHECKED                |         |          |
| APPROVED               |         |          |
|                        | U.O.M.  | MM       |

**UNISEN, INC. DBA** 14410 Myford Road  
 Irvine CA 92606

STARTRAC PART NO: **050-2042** REV: **A**

TITLE: **PACKAGING, BOX, E-UB**

SCALE: 1:14 SHEET 1 OF 1 SHEET SIZE: B

9 8 7 6 5 4 3 2 1