

REVISION HISTORY				
REV	DATE	DESCRIPTION	ECO	BY
A	2/16/2018	PRODUCTION RELEASE	15900	AW
B	4/26/2018	REMOVE 1X 740-9270. ADD 1X 718-5964, 1X 740-9240	15948	BA
C	8/8/2018	REMOVE 1X 740-9206; ADD 1X 718-5977	15997	BA

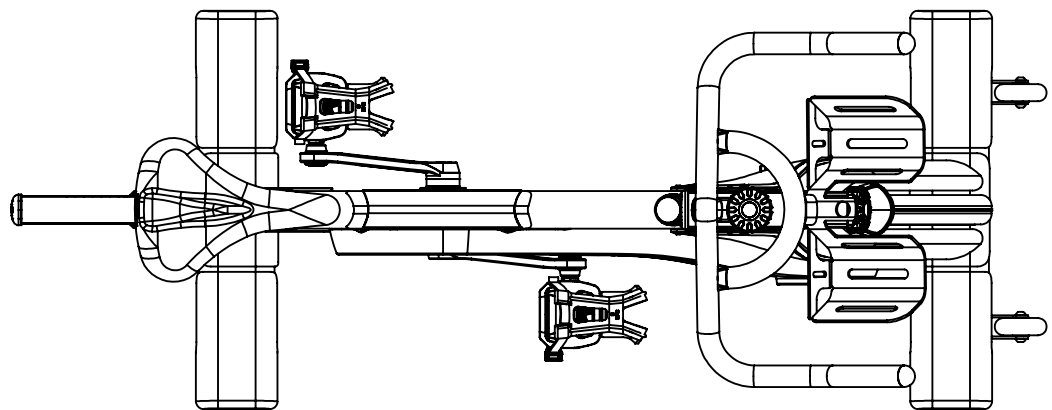
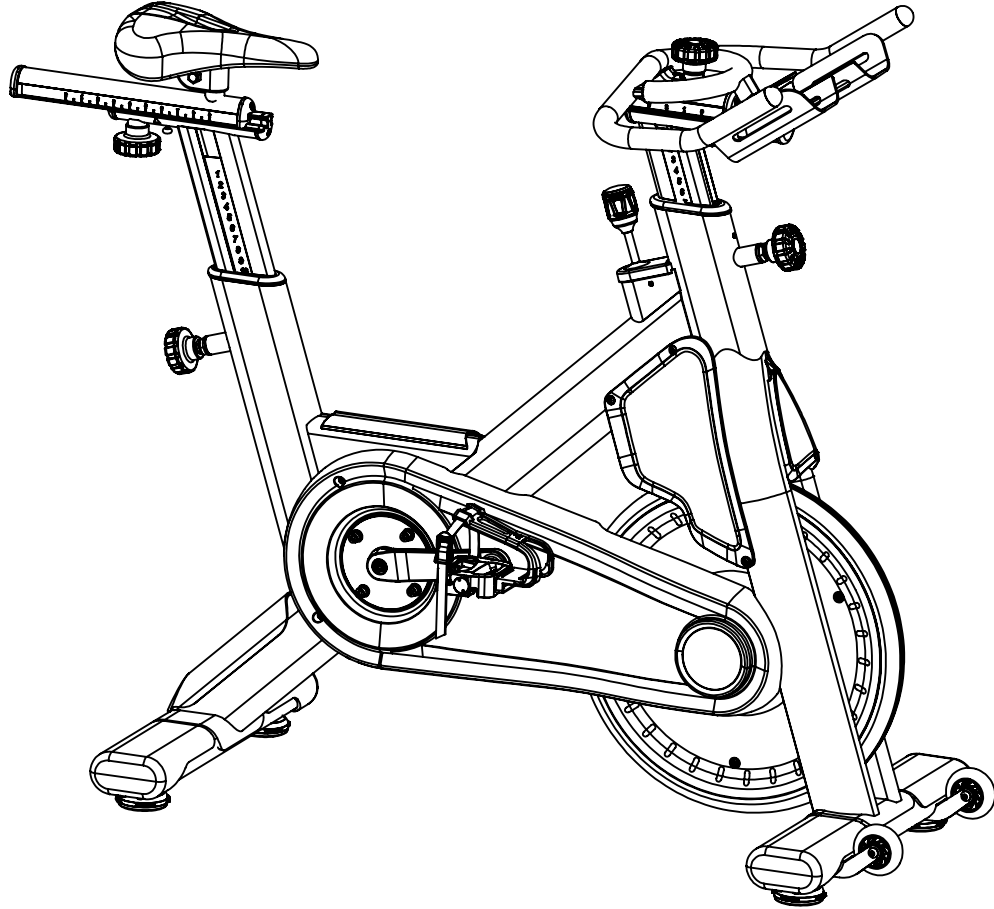
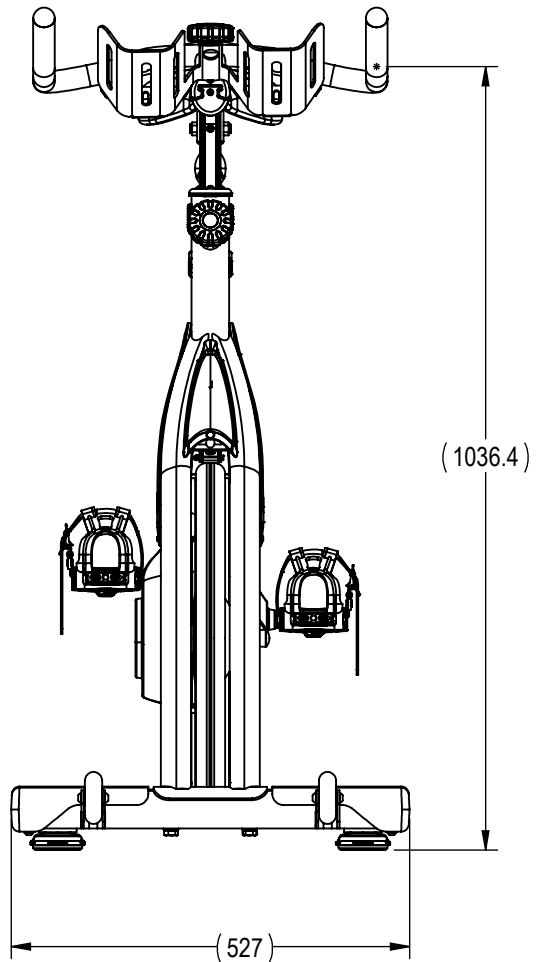
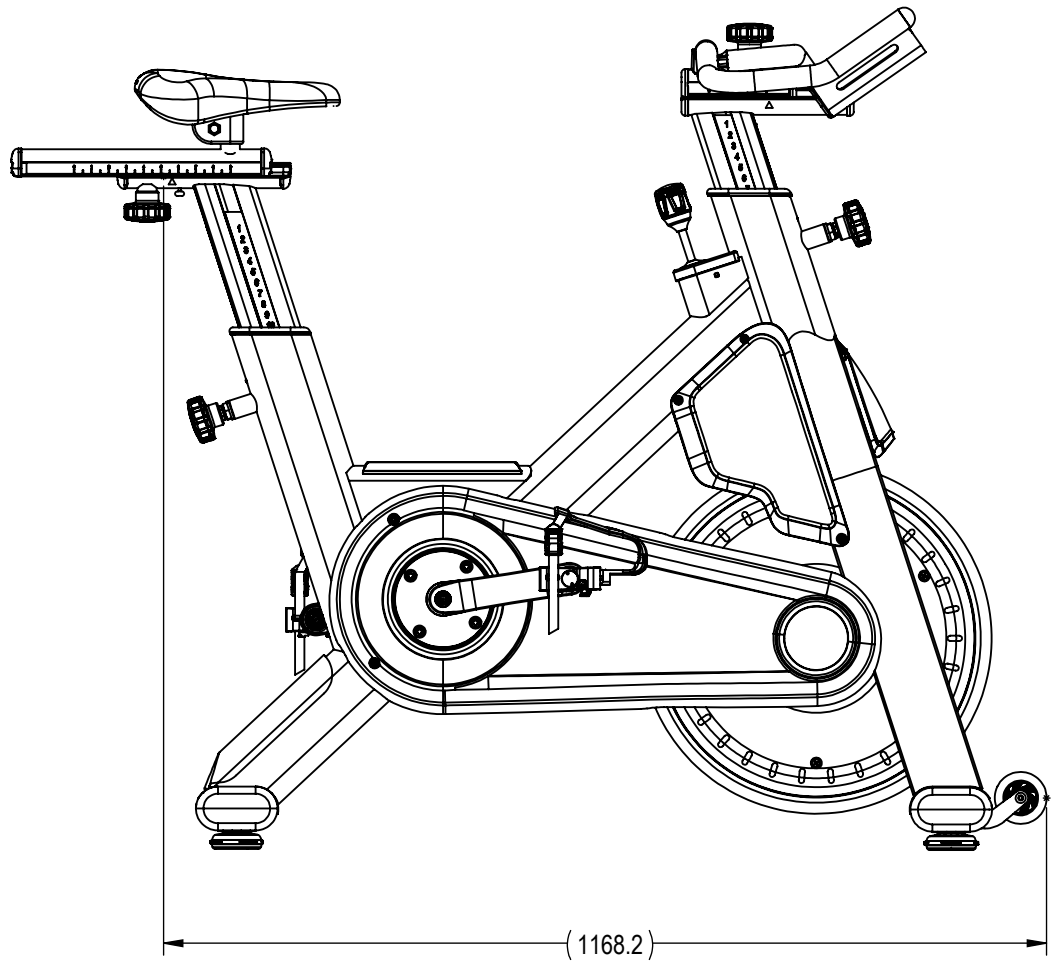

**DOCUMENT STATUS:
ECO**

NOTICE OF PROPRIETARY INFORMATION
THIS DOCUMENT SHALL NOT BE REPRODUCED NOR SHALL THE INFORMATION CONTAINED HEREIN BE USED BY OR DISCLOSED TO OTHER EXCEPT AS EXPRESSLY AUTHORIZED BY CORE HEALTH & FITNESS, LLC.

CLASS OF WORK	UNLESS OTHERWISE SPECIFIED DIMS ARE IN mm. TOLERANCES FOR MEASURE OF LENGTH ARE:							ANGLES = ±2°
	0.5 to 3	>3 to 6	>6 to 30	>30 to 120	>120 to 400	>400 to 1000	>1000 to 2000	
FINE	±0.05	±0.05	±0.1	±0.15	±0.2	±0.3	±0.5	----
MEDIUM	±0.1	±0.1	±0.2	±0.3	±0.5	±0.8	±1.2	±2
COARSE	±0.2	±0.3	±0.5	±0.8	±1.2	±2	±3	±4
VERY COARSE	----	±0.5	±1	±1.5	±2.5	±4	±6	±8

MATERIAL SEE BOM	
FINISH N/A	
VENDOR: N/A	P/N: N/A

THIRD ANGLE PROJECTION		
DRAWN	INITIAL Brian Alvey	DATE 08/08/2018
CHECKED		
APPROVED		
	U.O.M.	MM

CORE HEALTH & FITNESS, LLC 4400 NE 77th Ave., Suite 300 Vancouver, WA 98662		
CORE PART NO	REV	
7410-XXXXP0	C	
TITLE ASSY, BIKE, SC5		
SCALE: 1:10	SHEET 1 OF 5	SHEET SIZE: B

NOTES:

1. FOLLOW MFG SPEC ON PROPER INSTALLATION OF RIVET FASTENER
2. CLEAN AREAS WITH DENATURED ALCOHOL PRIOR TO ADHESION
3. TORQUE TO 11 ft-lbs 15 N-m
4. APPLY LOCTITE 242/243 MED STRENGTH THREAD LOCKER
5. DO NOT APPLY LOCTITE
6. TORQUE TO 45-50 N-m
7. TENSION BELT TO 90 HZ +/- 10 HZ
8. APPLY LOCTITE 609 ON OUTER FACE
9. TORQUE TO 65-67.8 N-m
10. COLOR DESIGNATOR -XX AS SPECIFIED IN SOP 620-8222

ITEM NO.	PART NUMBER	DESCRIPTION	QTY.
1	050-5469	DECAL, VERT, HBAR, S5, RT	1
2	050-5470	DECAL, VERT, HBAR, S5, LT	1
3	110-3548	Nut, Jam, M8x1.25mm, CS, ZP	2
4	110-3550	SPACER, BRASS GUIDE, SPINNER BELT	1
5	110-3557	SCREW, M5X0.8, BHC, HE, SS	2
6	110-3592	NUT, NYLOCK, M12 X 1.5	1
7	110-3672	NUT, M8 X 1.25, CS, NYLOC, BLK E-COAT, GR-10	2
8	110-3673	NUT, M6X1, CS, JAM, BLK E-COAT, GR-8	2
9	110-3675	SCREW, M6x1, 60mm, SHC, HK, CS, GR 8.8, BLK E-COAT	1
10	110-3676	SCREW, M8x1.25, 20mm, SHC, HK, AS, GR 12.9, BLK E-COAT	2
11	110-3677	SCREW, M8x1.25, 30mm, BHC, HK, AS, GR 10.9, BLK E-COAT	2
12	110-3678	SCREW, M5x0.8, 12mm, BHC, HK, CS, GR 8.8, BLK E-COAT	6
13	110-3680	SCREW, M4x0.7, 16mm, PHM, PH, CS, BLK E-COAT	6
14	110-3696	SCREW, M6x1, 75mm, SHC, HK, CS, GR 8.8, BLK E-COAT	1
15	110-3697	SCREW, M5x0.8, 30mm, SHC, HK, CS, GR 8.8, BLK E-COAT	2
16	120-3383	WASHER, M4, 4.3x10x1.4mm, BLK E-COAT	5
17	120-3384	WASHER, M6, SPLIT LOCK, BLK E-COAT	2
18	120-3386	WASHER, M5, 5.3x10x1mm, BLK E-COAT	9
19	120-3387	WASHER, M8, 8.6x16x1.6mm, BLK E-COAT	6
20	140-3248	SPACER, BRACKET, IDLER	2
21	140-3492	RIVET, DRIVE, BARREL, Ø.25" X .040"-.462"	2
22	140-3557	SPRING, 103N/mm, +/-5, 18 OD, 9 ID, 70mm LONG	1
23	718-5513	BUSHING, FLANGE, Ø6mm ID X Ø8mm X Ø19mm	1
24	718-5627-XX	Foot, Adjustable, Plastic	4
25	718-5726-XX	FENDER, FRONT, V2, S5	1
26	718-5729-XX	CHAINGUARD, OUTER, V2, S5	1
27	718-5935	ASSY, SEAT, W/ SLIDER, SC5/SC7	1
28	718-5964	ASSY, TOP, HBAR, SC5/7	1
29	718-5977	ASSY, BRAKE RESISTANCE, CARTRIDGE, SC5/S5	1

ITEM NO.	PART NUMBER	DESCRIPTION	QTY.
30	730-0907	WASHER, M10, SPLIT, LOCK	4
31	730-0908	WASHER, PLAIN, M10, SS	4
32	731-5793	SCREW, M5x0.8, 30mm, SHC, HK, CS, NKL	1
33	740-0013	NUT, M5x0.8, SS, NYLOC	1
34	740-7303	Nut, Rivet, Hex, M5X0.8	8
35	740-7548	SLEEVE, SEAT POST, RIBBED, S5	1
36	740-7587	SCREW, M10 X 1.5, 20mm, HHM, SS	4
37	740-7588	COVER, GUSSET	1
38	740-7997	SCREW, M5 x 0.8, 16mm, SHCS, SS	1
39	740-8145	BOLT, CRANKARM, M8	3
40	740-8524	BELT, POLY K, 6 RIB, NXT BELT	1
41	740-8526	WASHER, BRASS, 12.5 X 2	2
42	740-8944	ASSY, BRAKE, S5/S7	1
43	740-8948-XX	WELDMENT, FRAME, S5	1
44	740-8954	CAP, DOWNTUBE, RUBBER, S5	1
45	740-8955	SLEEVE, HBAR, RIBBED, S5	1
46	740-8956	TOP CAP, BRAKE, S5	1
47	740-8961-XX	ASSY, FLYWHEEL, S5/S7, BELT	1
48	740-8975	ASSY, BELT DRIVE BB, S5 / S7	1
49	740-8976-XX	ASSY, REAR STABILIZER, S5	1
50	740-8977-XX	ASSY, FRONT STABILIZER, S5	1
51	740-9014	CROSS BRACE, S5/S7	1
52	740-9015	ASSY, IDLER, S5	1
53	740-9016	BOLT, IDLER, SQ, S5/S7	1
54	740-9020	ASSY, SET, PEDALS, S5/S7	1
55	740-9022	CHAINGUARD, INNER, S5	1
56	740-9034	CAP, RUBBER, CHAINGUARD, S7	1
57	740-9036	NUT PLATE, ST BIKES	1
58	740-9201	KNOB, POP-PIN, ASSEMBLY, S5/S7	2
59	740-9210-XX	ASSY, FENDER, LEFT, V2, S5	1
60	740-9211-XX	ASSY, SIDE FENDER, RT, V2, S5	1
61	740-9239	ASSY, POST, HBAR 50mm, S5/S7	1
62	740-9257	CRANK, HD, MT3, MT2, LH	1
63	740-9266	ASSY, SEAT POST W/WEAR STRIP, S5	1
64	740-9271	ASSY, R CRANK W/PULLEY, S5/S7, 4iiii	1

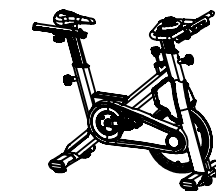

CORE HEALTH & FITNESS, LLC
 4400 NE 77th Ave., Suite 300
 Vancouver, WA 98662

CORE PART NO: **7410-XXXXP0** REV: **C**

TITLE: **ASSY, BIKE, SC5**

SCALE: 1:50 | SHEET 2 OF 5 | SHEET SIZE: B

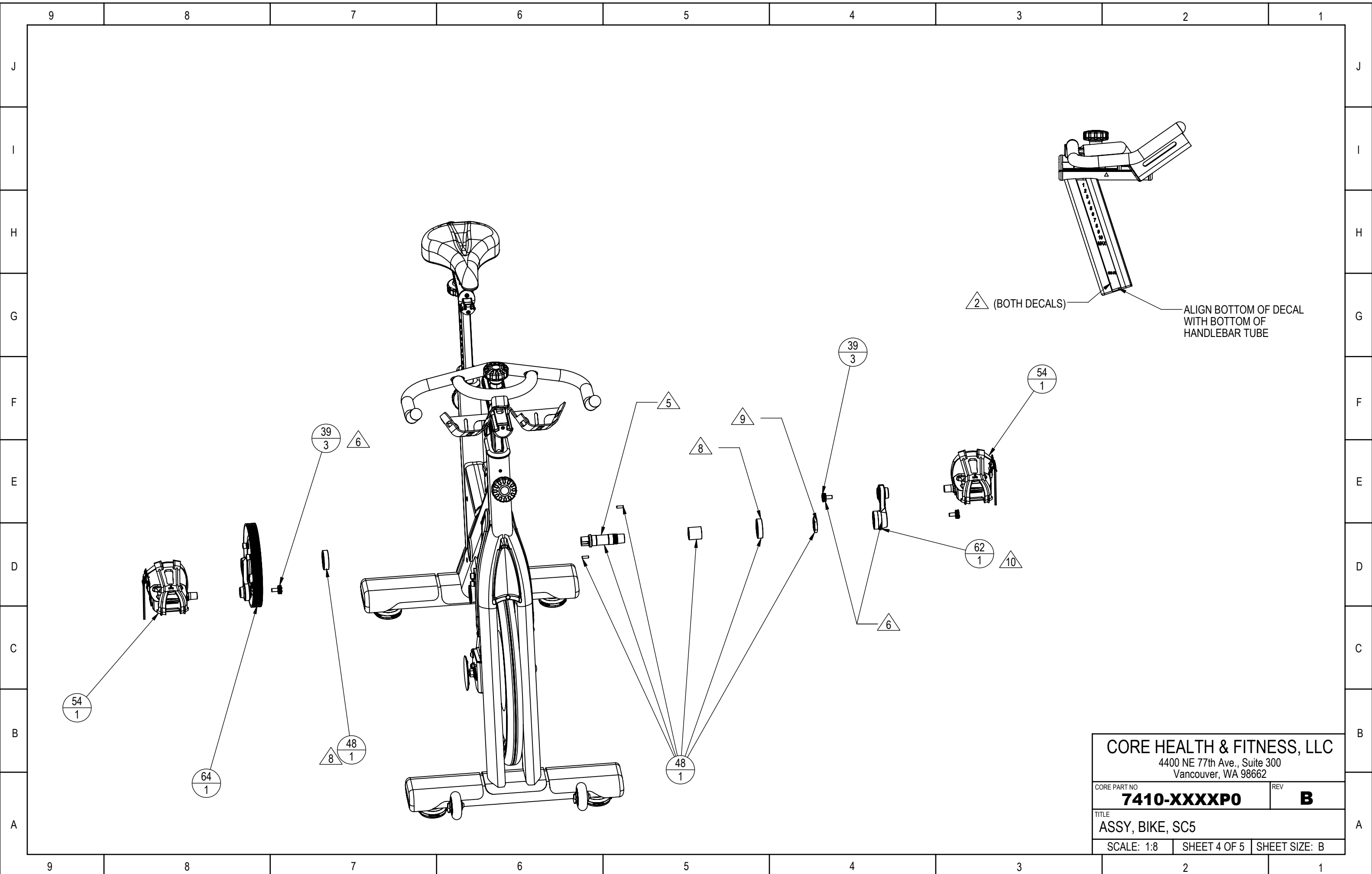

CORE HEALTH & FITNESS, LLC 4400 NE 77th Ave., Suite 300 Vancouver, WA 98662		
CORE PART NO	7410-XXXXP0	REV B
TITLE ASSY, BIKE, SC5		
SCALE: 1:8	SHEET 4 OF 5	SHEET SIZE: B

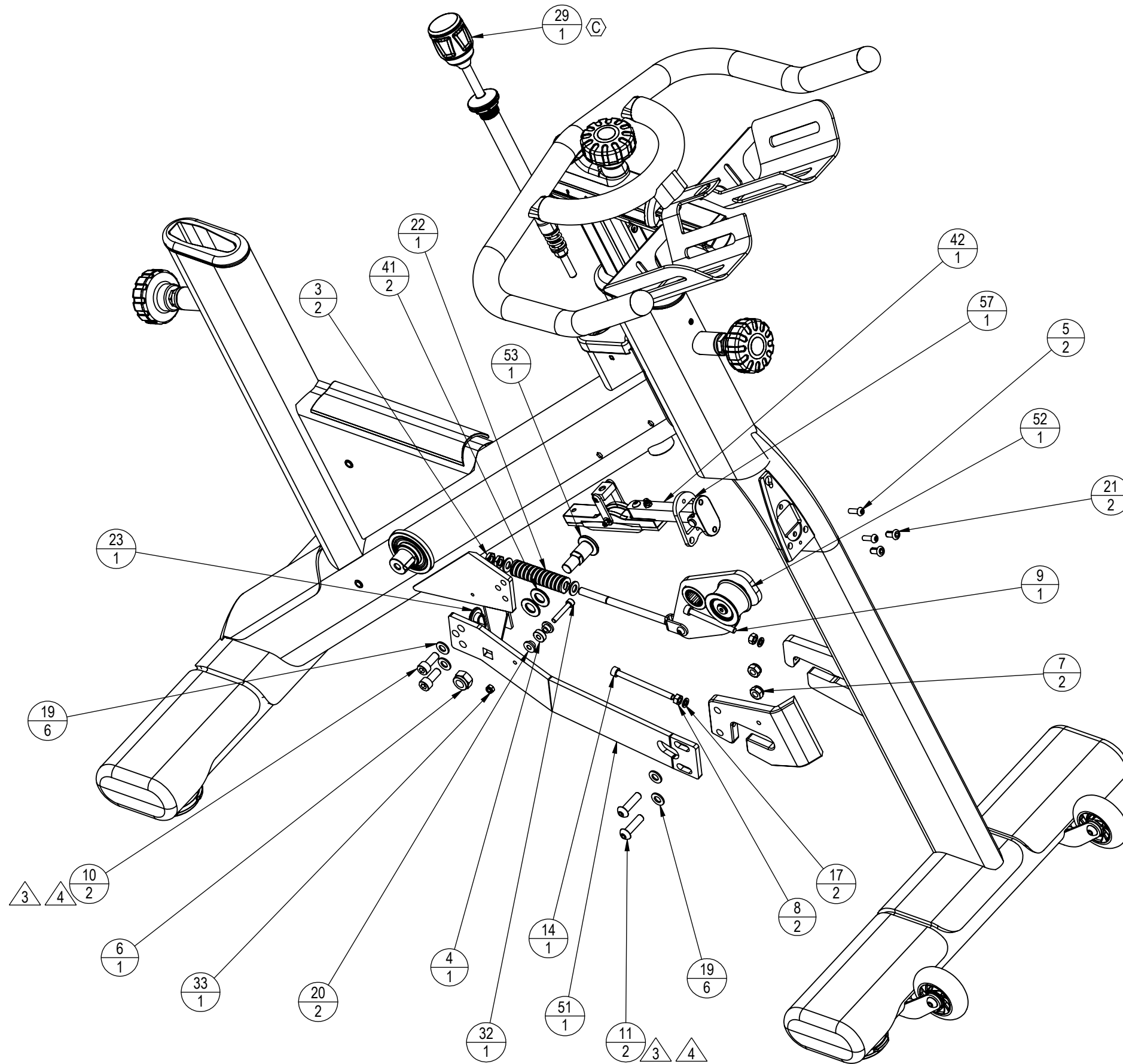

CORE HEALTH & FITNESS, LLC 4400 NE 77th Ave., Suite 300 Vancouver, WA 98662		
CORE PART NO	7410-XXXXP0	REV B
TITLE ASSY, BIKE, SC5		
SCALE: 1:5	SHEET 5 OF 5	SHEET SIZE: B