

S4 Weight Tower Components

BICEPS CURL

19-4110

REVISED:
July 26, 2006

PARTS AND SERVICE u 709 Powerhouse Road u Independence,
VA 24348

SERIAL # _____
through _____

FR30 FRAME KIT-30 WEIGHT TOWER COMPONENTS

- A01-0011 .BOLT HH5 1/2 X 3
- B01-1550 .BOLT HH5 3/8 X 3
- C02-1250 .BOLT ALLEN CAP 3/8 X 3
- D01-4030 .W HZ FLANGE BOLT 1/4-20 X 1
- E01-4046 .SCREW BUTON HEAD 3/8 X 1
- F02-6058 .1/2-13 X 3/4 SET SCREW
- G02-9190 .SCREW 1/4-20 x 3/4 TROX "F"
- H03-1035 .NUT NTE 3/8-16
- I03-1055 .NUT NTE 1/2-13
- J03-4290 .NUT W HZ FLANGE LOK 1/4-20
- K04-5075 .RUBBER W EIGHT STACK BUMPER 3/4 D X 1
..... 1/2 X 1" THICK
- L04-5213 .W ASHER LOK 3/8
- M04-5214 .W ASHER LOK 1/2
- N05-4020 .STANDARD GUIDE ROD W T BUSHING
- O05-4037 .TOP W EIGHT SLEEVE MOLDED
- POM IT
- Q06-2005 .CHAN LNK #100 CONNECTNG LNK
- R06-5044 .ROLLER ANTIJUMP BELT 3/8 D X 1 15/16 LONG
- S06-7064 .COL SUPER 6"
- T06-8150 .1 1/4 DIA EXTERNAL SNAP RING
- U06-8186 .1 1/4 D X 1 5/8 OD X 3/16 O-RNG
- V07-4000 .NYLNER PLASTIC BUSHING
- W07-8298 .PN W T.SEL W MAGNET 4 3/4" LENGTH YELLOW
- X07-8359 .BUSHNG PULLEY 7/8"DIA X .516 D X .985 LONG
- Y07-8982 .END STRAP CLAMP 1/4 X 2 HRF L1"
- Z09-5050 .S4 FOOTPAD (SANTOPRENE)
- AA ...07-9809 .SHEET METAL PLACARD SHIELD
- BB ...09-1195 .ACCESSORY TRAY MoBedABS (CobrPMS 432)
- CC ..09-3073 .9/16" BLACK HOLE PLUG
- DD ..09-3077 .5/16" BLACK HOLE PLUG
- EE ..09-6135 .BELT ROLLER
- FF ..09-8018 .GUIDE ROD BUSHINGS (SANTOPRENE)
- GG ..09-8330 .RED RECTIONAL PULLEY 4"
- HH ..12-1102 .DECAL WARNING 4 3/4"
- II12-1185 .DECAL, NAUTILUS LOGO (GREY) FOR S4 LNE
- JJ12-1292 .W EIGHT STACK DECAL 20-245 lbs & kgs (15b incr)-Bk
- KK ...17-2037 .W EIGHT PN13 HOLE (STUDD)
- LL ...17-2068 .W EIGHT TOP STEEL CBORE Steel15 bs 1 X 6 X 9.33
- MM ..17-2205 .W EIGHT BOTTOM Steel15 bs 1 X 6 X 9.33
- NN ..17-2207 .W EIGHT SECOND Steel15 bs 1 X 6 X 9.33 OPT-PKG-02
- OO ..07-7010 .ROLL PN 1/4 X 1
- PP ..07-9837 .5 LB. ADD ON W EIGHT
- QQ ..07-9838 .RELEASE HANDLE
- RR ..09-4085 .RUBBER BUMPERS
- SS ...12-1306 ..LFT TO REMOVE "DECAL
- TT ...12-1308 ..PULL TO RELEASE "DECAL
- UU ..10-2076 .COMP. SPRNG
- VV ...01-1551 .BOLT HH5 3/8 X 3 1/4
- WW ..04-2015 14 SAE FLAT W ASHER

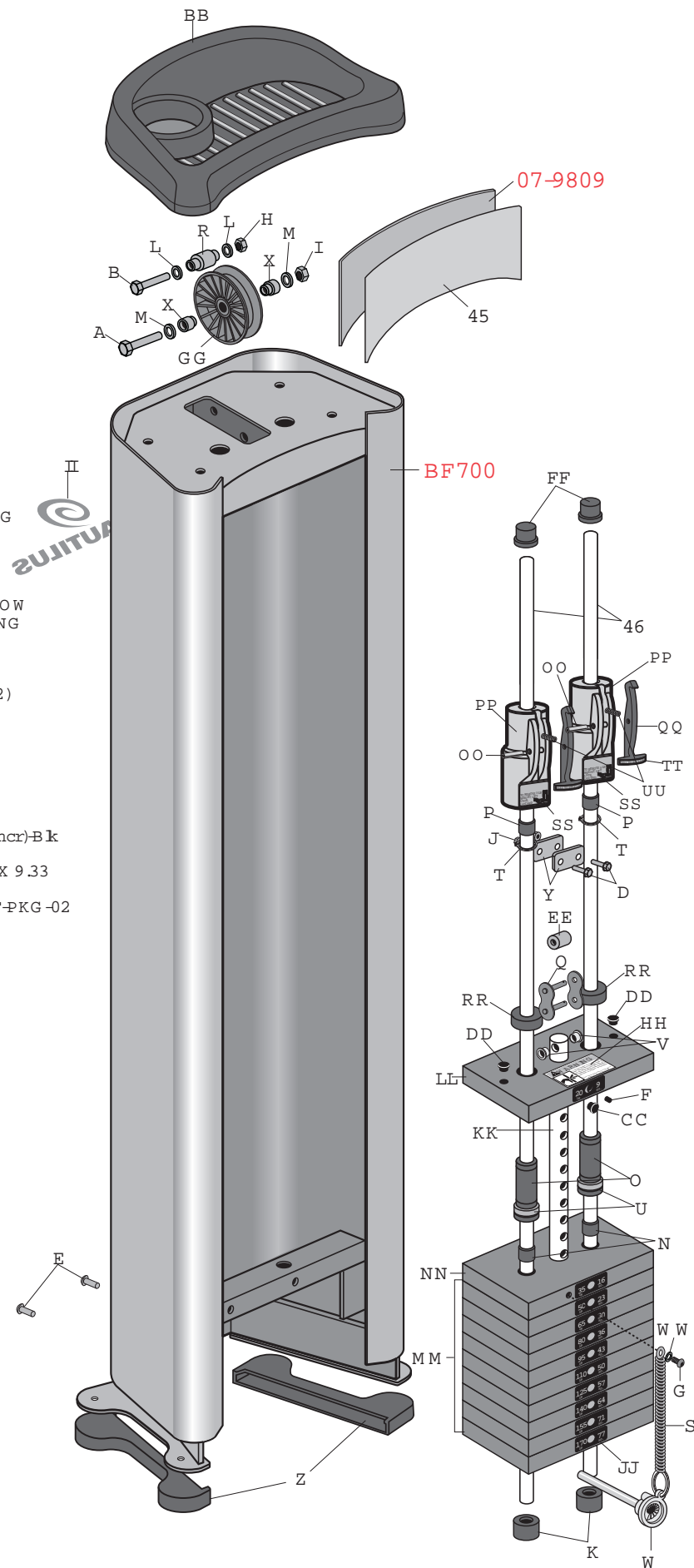

S4BC S4 Biceps Curl COMP # COMPONENT DESCRIPTION

- 1 ...01-0010 ...BOLT HH5 1/2 X 2 3/4
- 2 ...01-0011 ...BOLT HH5 1/2 X 3
- 3 ...01-1151 ...BOLT HH5 3/8 X 2 3/4
- 4 ...01-1185 ...BOLT HH5 3/8 X 3 1/2
- 5 ...01-1321 ...BOLT HH5 1/2 X 2 1/2
- 6 ...01-1550 ...BOLT HH5 3/8 X 3
- 7 ...01-2260 ...BOLT HH5 5/8 X 6 1/2 CUTOFF
- 8 ...01-4030 ...W HZ FLANGE BOLT 1/4-20 X 1
- 9 ...02-4129 ...1/4-20 SET SCREW
- 10 ...02-9220 ...BOLT HH5 3/8 X 1 1/4
- 11 ...03-1035 ...3/8-16 LOCK NUT
- 12 ...03-1055 ...1/2-13 LOCK NUT
- 13 ...03-1067 ...NUT NTE 5/8
- 14 ...03-4290 ...NUT W HZ FLANGE LOK 1/4-20
- 15 ...04-5213 ...3/8 NT LOK W ASHER
- 16 ...04-5214 ...1/2 LOCK W ASHER
- 17 ...06-5044 ...ROLLER ANTIJUMP BELT
- 18 ...OM IT
- 19 ...07-4125 ...PULL PN ASSEMBLY (SHORT TAPERED PN)
- 20 ...07-6041 ...1 1/4" LOCK COLLAR
- 21 ...07-8359 ...BUSHNG PULLEY 7/8"DIA X .516 D X .985 L.
- 22 ...07-9760 ...BUSHNG PULLEY 7/8"DIA X .516 D X .859 L.
- 23 ...07-8982 ...END STRAP CLAMP 1/4 X 2 HRF L1"
- 24 ...07-9276 ...NYLON SLIDE
- 25 ...07-9277 ...PLUG /SLIDE
- 26 ...07-9607 ...STD .MOLDED BEARING CUP 6203
- 27 ...07-9771 ...LNKAGE BUSHING 7/8 DIA ALUM .
- 28 ...07-9775 ...BEARING SLEEVE ZNC PLATED
- 29 ...08-2053 ...MOLDED MA HUB SPACER
- 30 ...08-5096 ...1/2 ID .X 3/4 LENGTH PLASTIC SPACER
- 31 ...09-9545 ...ALUM NUM RNG 1 1/4" ID .
- 32 ...09-1059 ...NEOPRENE CURLGRP 25" length
- 33 ...09-2070 ...2" X 2" FRAME PLUG
- 33A ..09-8025 ...V NYL CAP RED 1" X 1/2 L.
- 34 ...09-4040 ...3/4" CRUTCH BUMPER RUBBER 3/4D #18
- 35 ...09-5030 ...ROUND FOOTPAD
- 36 ...09-5035 ...3/8 X 2" FOOT PAD MOLDED
- 37 ...09-5045 ...3/8 X 2 1/2 FOOT PAD MOLDED
- 38 ...09-9515 ...ALUM NUM CAP 1 1/4" ID .
- 39 ...09-8323 ...2" PULLEY
- 40 ...09-8327 ...3" PULLEY
- 41 ...09-8329 ...3" W DE PULLEY
- 42 ...12-1026 ...KEEP HANDS AWAY (YELLOW)
- 43 ...12-1074 ...SEAT DECAL BLACK, 3/4"W IDE X 3/4" NCREM .
..... (1 TOP-11)
- 44 ...12-1380 ...INSPECTION STICKER DECAL
- 45 ...12-5272 ...S4BC PLACARD
- 46 ...17-1263 ...GUIDE RODS 45 1/2" LONG
- 47 ...19-1291 ...DECAL SERIAL # BAR CODE
- 48 ...19-4110 ...PARTS DIAGRAM "S4LR"
- 49 ...24-6035 ...MECTROL 1" BELT (140")
- 50 ...40-7167 ...BAG 50 X 46 X 86 X .002 THICK
- 51 ...45-1062 ...BUSHING GUS GLDLE L280
- 52 ...91-999 ...PAINT POWDER
- 53 ...BF700S4 STANDARD W EIGHT FRAME (SHORT)
- 54 ...CM 703BICEPS MAINFRAME CROSSMEMBER
- 55 ...FR 30FRAME KIT-30 W EIGHT TOWER COMPONENTS
- 56 ...MA 704S4BC BICEP MOVEMENT ARM
- 57 ...MA 710S4BC BICEP CURLBAR
- 58 ...SE 703Standard SEAT
- 59 ...SF 704BICEPS SEAT FRAME
- 60 ...UP 727SLP COVER
- 61 ...UP 8085 ...STD .SEAT BOTTOM PAD
- 62 ...UP 8041 ...STD .CURL ELBOW PAD
- 63 ...02-3035 ...SET SCREW 1/4-28 X 1/4
- 64 ...SF 703BICEPS SDE FRAME
- 65 ...09-9600 .TUBE INSERT
- 66 ...02-2290 .AFH SCREW 1/4 X 1
- 67 ...09-8000 .MOLDED BELT CLAMPNG FERRULE



RED : PAINTED ITEMS
____ Trolleys / Machine

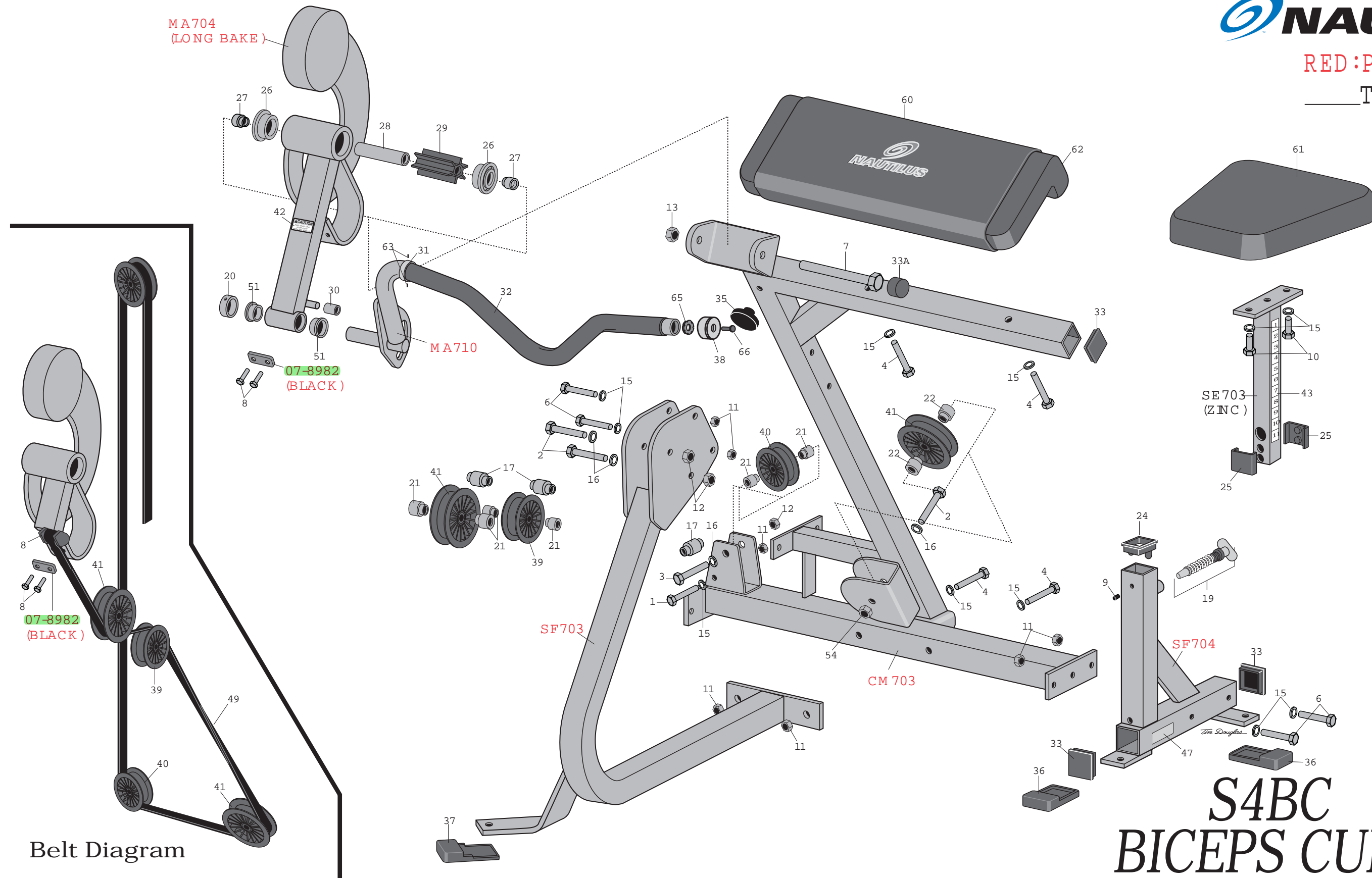

Last Rev Date: 07/26/06

S4BC BICEPS CURL Nautilus Parts Diagram



Warranty Information

Nautilus® Studio Variable Resistance Warranty Limited Warranty Terms & General Specifications

Nautilus warrants only to the original purchaser that Nautilus® commercial exercise equipment from the manufacturer is free from defects in material and workmanship under normal use and service. Our obligation under this warranty shall be limited to the repair or exchange at our plant (a) of any part or parts of the structural frame, moving weldments or weight stacks which may thus prove defective under normal use and service for 12 years from delivery to the original purchaser; (b) of any moving part or parts not otherwise disclosed within this warranty which thus may prove defective under normal use and service within one (1) year from delivery to the original purchaser; and (c) of any upholstery, pads, grips or tethered weight pin connectors which thus may prove defective under normal use and service within 6 months from delivery to the original purchaser. This warranty only applies to those parts that our own examination discloses to our satisfaction to be thus defective. Nautilus will replace, free of charge, safety /caution decals which are missing or damaged.

WARNING
Store indoors only. Do not subject machine to high humidity or damp conditions.

Nautilus Equipment Warranty	
2ST, Nitro Plus/Nitro, Studio, XP Load, and Free Weights	
12 Years	To original owner for frames, welded moving parts and weight stacks.
3 Years	To original owner under normal use and service for any moving part or parts not otherwise disclosed in this warranty.
1 Year	Labor warranty - To original owner.
6 months	Upholstery, pads, grips and tethered weight stack pins.
Equipment schematics available online at www.nautilus.com for faster repair diagnosis and parts delivery.	

This warranty is expressly in lieu of all other warranties, express or implied, including the warranties of merchantability and fitness for use and of all other obligations or liabilities on our part, and we neither assume nor authorize any other person to assume for us any other liability in connection with the sale of this NAUTILUS® commercial exercise equipment. This warranty shall not apply to this NAUTILUS® commercial exercise equipment or to any part thereof which has been subject to accident, negligence, alteration, abuse, misuse, or a lack of maintenance in accordance with our recommended maintenance instructions. We make no warranty whatsoever in respect to accessories or parts not manufactured by us and disclaim all warranties, express or implied, as to such accessories and parts. The term “original purchaser”, as used in this warranty, shall be deemed to mean that person or entity for whom this NAUTILUS® commercial exercise equipment is originally installed. This warranty shall apply only within the boundaries of the continental United States.

NAUTILUS® shall not be liable for any loss or damage, including incidental or consequential damages resulting directly or indirectly from the use or loss of use of our NAUTILUS® commercial exercise equipment. Without limiting the generality of the foregoing, this exclusion from liability embraces the purchaser’s expenses for downtime or for making up downtime, damages for which the purchaser may be liable to other persons, damages to property, and injury to or death of any persons. We neither assume nor authorize any person to assume for us any liability in connection with sale or use of our equipment. There are no oral agreements or warranties collateral to or affecting this agreement.

Dealer Acknowledgment Notice:

Nautilus Commercial Warranty times begin 30 days after product has been shipped from our manufacturing plant to your warehouse or storage site, unless otherwise specified at time of customer pickup.



Maintenance INSTRUCTIONS

For Studio Strength Training Equipment

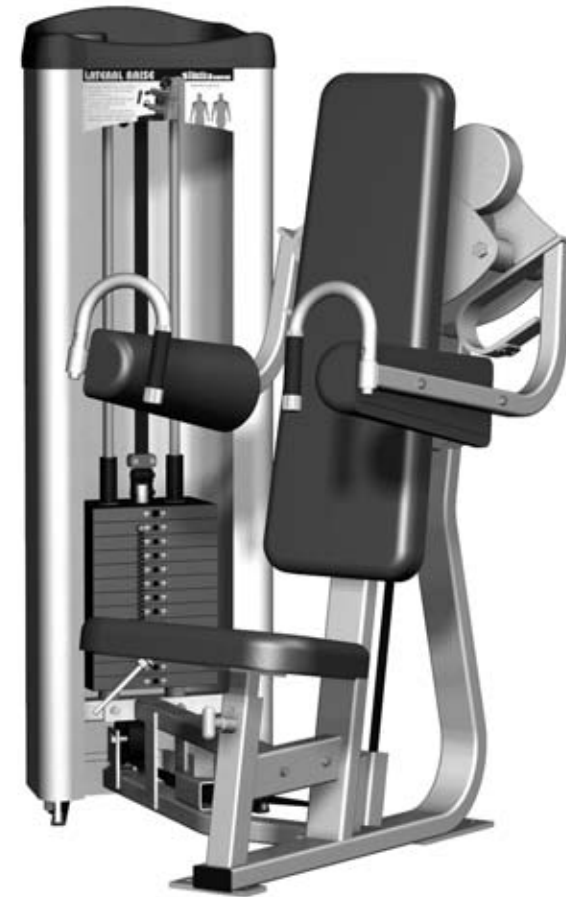

Getting maximum results from Nautilus® machines depends on proper maintenance of equipment.

Welcome

Congratulations on choosing Nautilus® Studio™ strength training equipment. The addition of several exciting new features to the Nautilus® line, as outlined in these instructions, ensures that your equipment will operate with little scheduled maintenance. We know this is important to you and your customers, so please take a few minutes to read the following instructions for keeping your Nautilus® equipment in the best working condition.

Contents

- Welcome1
- Parts & Service1
- Safety/Before Exercising2
- Maintenance Schedule2
- General Maintenance3
- Mini-Weight Stack Pin Replacement.....3
- Cleaning.....3
- Lubrication3
- Warranty Information4

Parts & Services

Regular and scheduled maintenance will prolong the life of your Nautilus equipment. Should you have to replace parts, use only genuine Nautilus parts. The Nautilus Customer Service Team invites you to call in your order for replacement parts. They're never too busy to discuss or offer a tip on your maintenance tasks.

Nautilus machines -- the culmination of years of research and refinement -- are made from the highest quality materials, under exacting conditions. The quality control tag attached to each machine before shipping ensures that each unit has been thoroughly inspected to meet Nautilus' strict requirements.

Should you, the owner of a Nautilus machine, need to replace any parts because of normal wear and tear, or should your machine ever need maintenance, Nautilus invites you to call our Virginia Headquarters office for information on parts and service.

Nautilus has available: detailed isometric drawings on the website @ www.nautilus.com for each machine manufactured, genuine Nautilus Upholstery Pads, Naugahyde® Spray Cleaner/Conditioner recommended for Nautilus upholstery pads and TFL #50 Wet Lubricant recommended for the care of the guide rods of Nautilus selectorized resistance machines.

Nautilus' concern for the customer does not end with the purchase of equipment. Your comments are always welcomed. In the unlikely event that a problem occurs, call us toll free:



Nautilus Customer Service
800-NAUTILUS
Fax: 276-773-2298

Safety

- Supervision is necessary when the machine is used by or near children, invalids, or disabled persons.
- Follow the instructions for specific exercises on each machine
- Get in and out of the equipment carefully.
- Never operate the machine without shields in place.
- Use only Nautilus selector pins in weight stack. Never drop or insert any other object into machine opening.
- Use this machine only as intended or described in this manual.
- Do not operate equipment with loose or damaged parts. If machine fails to operate correctly, do not attempt to repair. Notify authorized personnel of the problems.
- Keep hands and feet clear of weights and other moving parts when in use. Keep hands and feet only on the hand grips and foot pads provided.
- Failure to comply with these instructions may result in personal injury.

Nautilus will replace, free of charge, safety /caution decals which are missing ordamaged.

CAUTION

Stop exercising immediately if you experience a sharp nerve or joint pain, and seek medical advice.

Maintenance Schedule

	DAILY	WEEKLY	MONTHLY	EVERY 6 MONTHS
General Maintenance				
Check Safety & Warning Decals	<input type="checkbox"/>			
Inspect Belts & Cables	<input type="checkbox"/>			
Spot Check Belt			<input type="checkbox"/>	
Spot Check Nuts and Bolts			<input type="checkbox"/>	
Spot Check All Pegs and Stops			<input type="checkbox"/>	
Examine Rotation Points				<input type="checkbox"/>
Cleaning				
Clean Upholstery	<input type="checkbox"/>			
<i>Use Quick Fill A-33 Disinfectant Cleaner.</i>				
Clean Surface Area		<input type="checkbox"/>		
Remove Dust			<input type="checkbox"/>	
Lubrication				
Lubricate and Clean Guide Rods Using TFL 50		<input type="checkbox"/>		
<i>Do not lubricate hydraulic cylinders.</i>				

Before Exercising

To guard against injury, all equipment users should follow these instructions.

- Check with your physician and get approval before beginning a training routine.
- Become familiar with the equipment before beginning a training routine.
- Always warm-up before and cool down after exercising.
- Move slowly during each exercise. Do not jerk or "throw" the weight.
- Breathe freely. Do not hold your breath while lifting or lowering weight.
- Hold movement arms and handles firmly, do not squeeze or grip tightly.
- Structure each workout to exercise the largest muscles first. Suggested routines are found in the Nautilus Total Fitness Program.
- Experiment to find the exact weight you need for each exercise. Select a resistance that allows you to perform eight to twelve slow repetitions. Take two seconds to lift the weight. Pause briefly, and take four seconds to lower the weight.

General Maintenance

Frequency of maintenance is determined by several factors: temperature, humidity, use, ventilation and filtration, shielding and friction. External maintenance may vary from daily to monthly, internal maintenance from six months in a club environment to a year when used in a multi-user setting.

- SPOT CHECK LOOSE NUTS AND BOLTS**
 - Carefully check rotation points.
 - Tighten loose parts immediately. Also check for worn parts, seat belts and upholstery pads.
- UPHOLSTERY PAD TIGHTENING**

Most bolts on upholstery pads can be tightened with a 9/16" combination wrench.
- SHIELD REMOVAL**

Some Nautilus® machines are equipped with quick-release shield fasteners. To remove Quick-Release shielding, gently pull shielding away from the frame. Use a proper screwdriver to remove shield, which is attached to the frame with screws.
- SHIELD INSTALLATION**

Snap Quick-Release in place. Tighten screws only snugly. Use correct phillips screwdriver.

Mini-Weight Pin Replacement

- To gain access to mini-weight stack pin, remove selector pin, grasp and pull belt to raise top weight and place selector pin into weight stack pin as shown.
- Remove allen cap screws and lock nuts with allen wrench and adjustable wrench.
- Remove molded weight pin. Insert new molded weight pin in guide rod. Replace allen screws and lock nuts, (DO NOT TIGHTEN).
- Make sure that weight pin is properly aligned. There should be equal distances on each side of weight bracket. See figure below for proper placement.
- Remove selector pin and slowly lower top weight. To adjust weight pin, select bottom mini-weight with selector pin. The small selector pin should guide into nylon weight pin with ease. If the pin does not select properly, then the guide rod needs to be adjusted. With 3/4" open-end wrench, loosen top nut, back bottom nut back and lower or raise guide rod. Check bottom weight for proper selection. Tighten guide rod nuts, allen screws and nuts. If weight selection is difficult, then the add-on weight bracket may be bent.

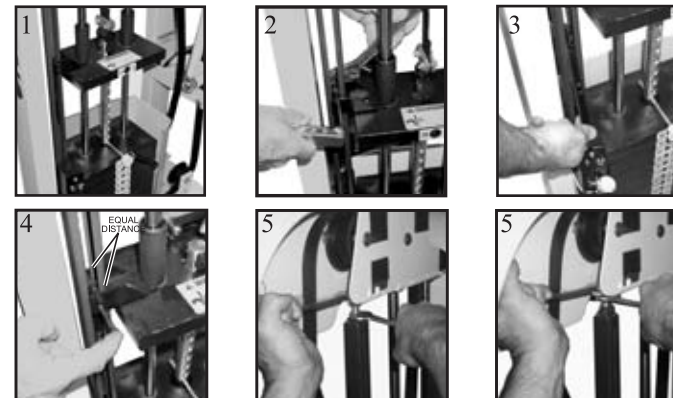

Cleaning

- UPHOLSTERY CLEANING AND PROTECTION**
 - Keep pads free of perspiration at all times.
 - Clean and disinfect upholstery at the end of each day, especially areas where perspiration and scalp oil collect.
 - Clean all outside surfaces with non-abrasive, non-chlorinated household cleaners. Virahol® Disinfectant Cleaner is an effective upholstery care product.
- CLEANING AND CARE OF PAINTED SURFACES**
 - Wipe painted surfaces with a damp cloth and car wax.
 - Let dry and buff with a dry cloth.

QUICK FILL A-33

Detergent/Disinfectant Odor Counteractant



An Outstanding liquid quaternary-based product for use in areas where there's heavy soiling. Provides the best odor counteraction available from a disinfectant. Available in ready-to-use; no mixing or dilution 16 oz. spray bottle. USDA Code 1, EPA Reg. 42964-

TO PLACE AN ORDER

Give our friendly Customer Service Representatives a call to order this product or any other Genuine Nautilus Parts

1-800-235-2233

PART NUMBER 19-1175

Lubrication

MOVING PARTS

To clean and lubricate guide rods, apply TFL#50 Wet Lubricant to a clean cloth then use to wipe rods.

***TFL 50 Wet Lubricant Recommended for Nautilus Machines.**

WARNING Do not lubricate MINI WEIGHTS. May cause damage and VOID WARRANTY.

PART NUMBER 19-1160

Do not place equipment in direct sunlight as ultra violet rays can damage shields and upholstery.

