

**Nautilus** *OWNER'S MANUAL*  
**FREE WEIGHT  
ADJUSTABLE HIP  
EXTENSION**

**Contents**

**Parts Manual**

- 1 LINKAGE BAR ASSEMBLY
- 2 LINKAGE TO BASE ASSEMBLY
- 3 PARTS LIST

**Maintenance Manual**

Follows page 3

See last pages of this manual for Sample Training Record.

REVISED: July 13, 1999

SERIAL NO.'S

through

**PARTS AND SERVICE**

709 Powerhouse Road  
Independence, VA 24348  
800-235-2233 • Fax: 540-773-2298



F2AHE

**Nautilus** LINKAGE BAR ASSEMBLY

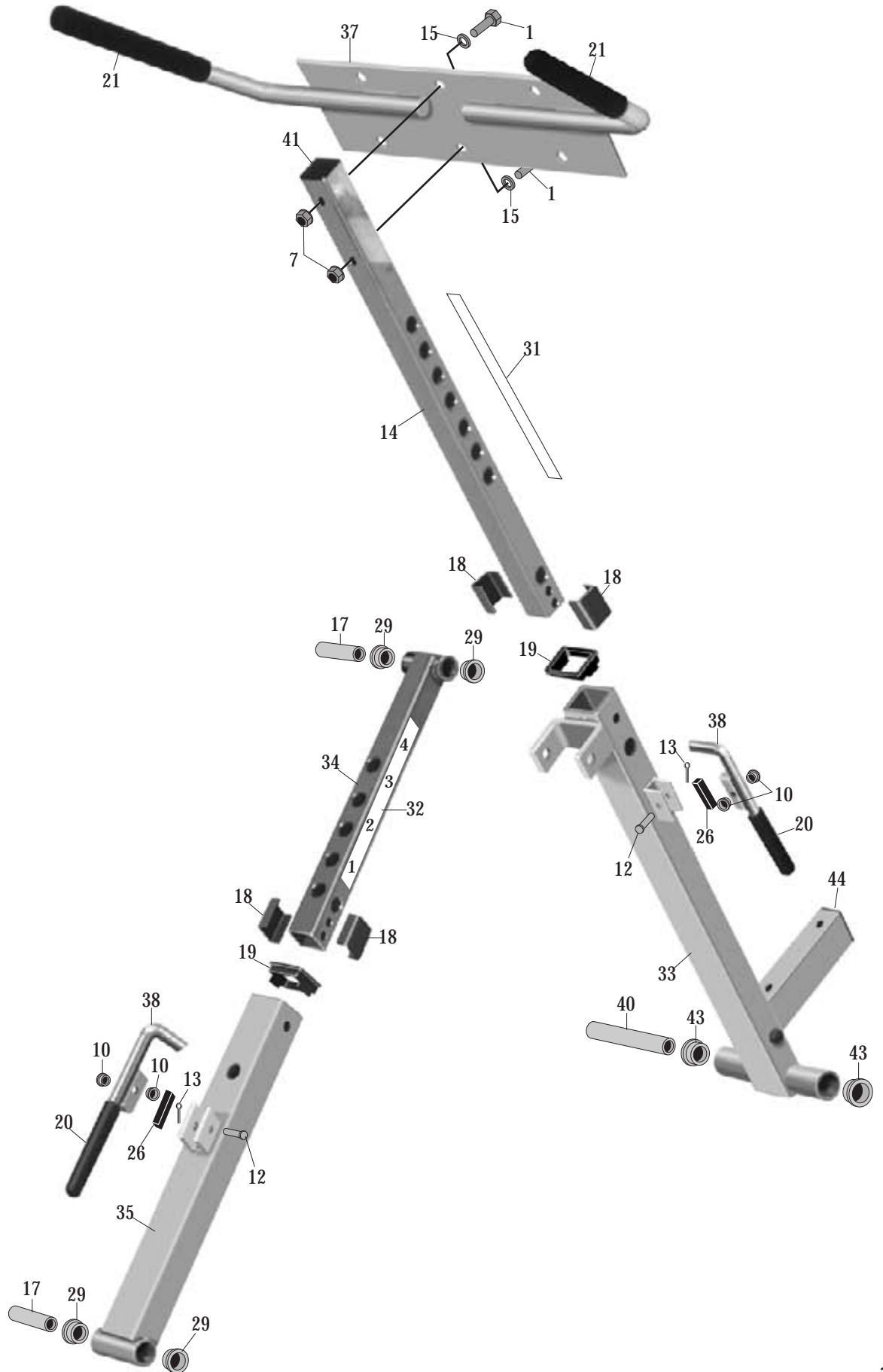

**Nautilus** LINKAGE TO BASE ASSEMBLY

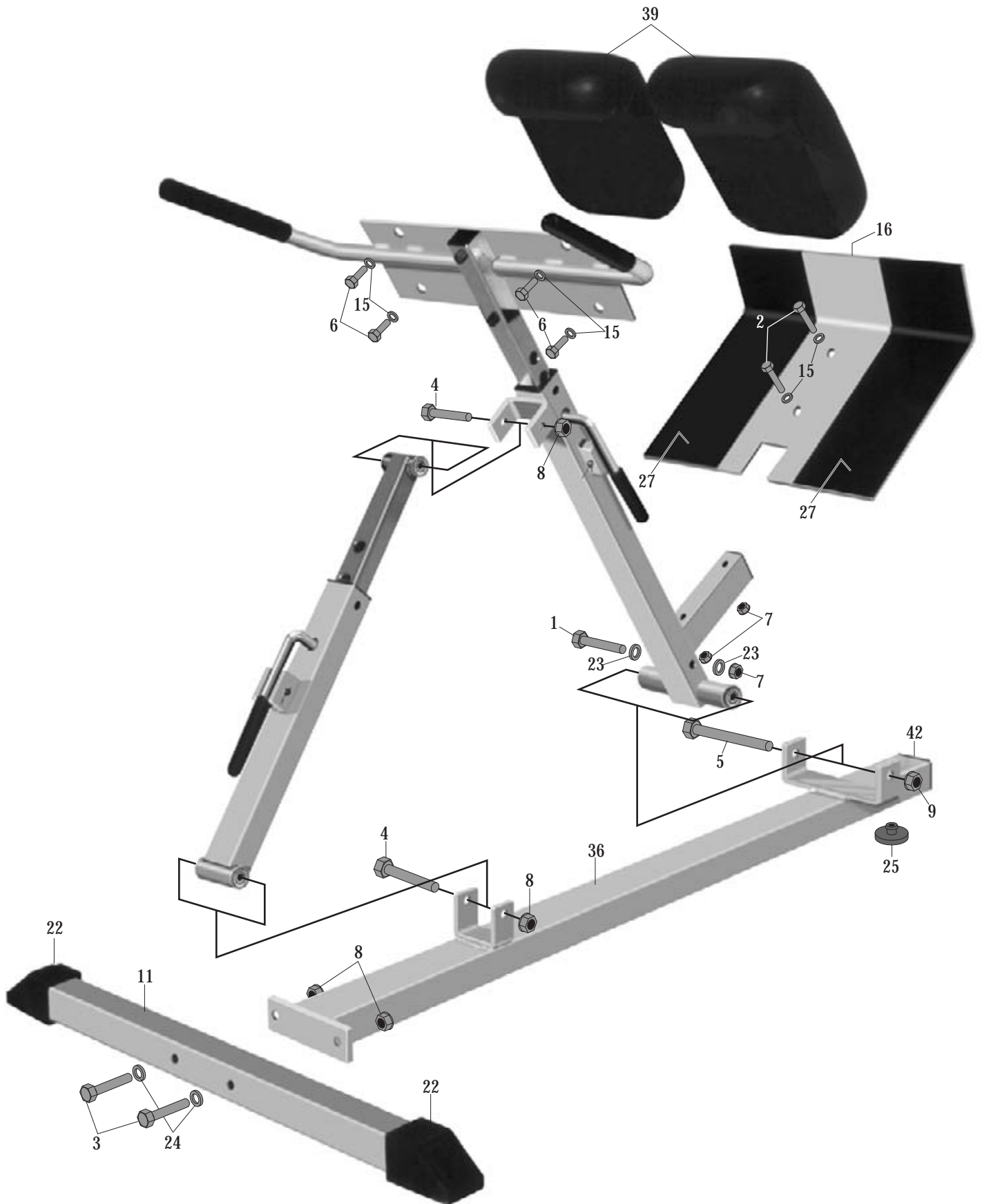

## F2AHE ADJUSTABLE HIP EXTENSION

Ref#	Part#	Description
1	01-1115	BOLT HH5 3/8 X 2 1/2
2	01-1185	BOLT HH5 3/8 X 3 1/2
3	01-1340	BOLT HH5 1/2 X 3
4	01-1362	BOLT HH5 1/2 X 3 1/2
5	01-2282	BOLT HH5 5/8 X 8 1/2
6	02-9220	BOLT HH5 3/8 X 1 1/4 (UPH)
7	03-1035	NUT NTE 3/8
8	03-1055	NUT NTE 1/2
9	03-2060	NUT NTE 5/8
10	05-5118	IGUS BUSHING LFI-0607-04,3/8 ID
11	07-5183	FRONT BASE TUBE
12	07-8026	CLEVIS PIN 3/8 DIA. X 1 1/8 L.
13	07-8127	COTTER PIN 1/8 X 3/4 L.
14	07-8391	F2AHE THIGH SUPPORT INNER TUBE
15	04-2020	WASHER 3/8
16	07-9003	PLATFORM
17	07-9017	PIVOT SLEEVE
18	07-9276	NYLON SLIDE
19	07-9227	PLUG / SLIDE
20	09-1005	RUBBER HAND GRIP 1/2 X 5 FOAM
21	09-1050	FOAM GRIP 7/8 X 8 1/2
22	09-1190	KAMWAY FEET 2 X 2 SQUARE
23	04-2021	WASHER 3/8 USS
24	04-5203	WASHER 1/2 USS
25	09-5030	FOOT PAD ROUND MOLDED
26	10-4015	RACHET SPRING
27	19-1025	3M SAFETY-WALK 7 1/2" WIDE X 18 1/2"
28	19-5211	PARTS MANUAL F3AHE
29	45-1051	IGUS BUSHING
30	91-999	PAINT POWDER
31	12-1078	DECAL 1 - 7 SEAT ADJ.
32	12-1126	DECAL 40 -60 DEGREES
33	AAB209	F2AHE THIGH SUPPORT OUTER TUBE
34	AB210	F2AHE LINK INNER TUBE
35	AB211	F2AHE LINK OUTER TUBE
36	BSF225	F2AHE BASE FRAME
37	HB219	F2AHE HANDLE & THIGH SUPPORT
38	HB220	RATCHET HANDLE
39	UP9115	THIGH PAD
40	08-5064	PIVOT SPACER 1" DIA X 7 7/32 L.
41	09-2020	TUBE PLUG 1 1/2 SQ 11 GA
42	09-2090	TUBE PLUG 2 X 3 11 GA
43	45-1062	BUSHING IGUS 3/4" ID X 3/4 L.
44	09-2060	TUBE PLUG 1 1/2 X 3 X 11 GA
	IN02	INSPECTION KIT
45	12-1080	INSPECTION STICKER DECAL
46	12-1089	NAUTILUS NAMEPLATE 1 1/2 X 6 1/4 L PLASTIC
47	19-1291	DECAL SERIAL # BAR CODE
48	40-7167	BAG 50 X 46 X 86 X .002 THICK