

This document contains information proprietary to Magnum Fitness Systems. It is submitted in confidence and is to be used solely for the purpose for which it is furnished. This document and such information is not to be reproduced, transmitted, or used in whole or part without written authorization.

TOLERANCES: + 0.000"
- 1/16"

UNLESS OTHERWISE SPECIFIED
DIMENSIONS ARE IN INCHES.

DRAWN BY:
Josh Ellis

DATE:
03/13/06

PART NO.
xxx-xxx

JOB NO.
XXXXXXXX

REV:
1

MAGNUM FITNESS SYSTEMS

2201 12th. Avenue
S. Milwaukee, WI, 53172

TITLE: M49 - Angled Smith Press

FILE LOCATION: C:\Cad Drawings\Solid Works\

1 OF 2

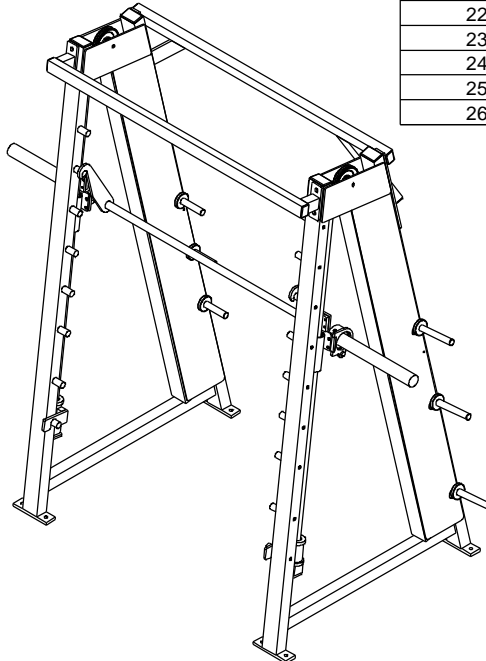

ITEM NO.	QTY.	PART NO.	DESCRIPTION
1	1	100-433	Main Frame - Right Side
2	1	100-432	Main Frame - Left Side
3	1	100-431	Top Support - Rear
4	1	100-430	Top Support - Front
5	1	100-429	Weight Bar
6	2	100-428	Slide
7	1	100-427	Safety Stop
8	1	100-426	Safety Stop - Right
9	1	100-425	Weight Bar Connector
10	1	100-424	Weight Connector w/ Stop
11	2	100-423	Counter Weight
12	18	339-903	Chrome Peg
13	2	200-456	5/8" GUIDE ROD - 67"
14	2	851-063	1" LINEAR SHAFT - 63 7/8"
15	4	852-610	5/8" SET COLLAR
16	4	850-006	2" X 3" END CAP
17	6	850-010	1 1/2" X 2" END CAP
18	2	700-508	1/8" ABS
19	2	700-509	1/8" ABS
20	2	853-308	4" CABLE PULLEY - 3/8" HOLE
21	4	851-203	1" LINEAR SHAFT BEARING
22	4	339-714	1/2" x 1 1/2" F.S. - 2 1/4"
23	4	851-506	1" ID Flange Bushing
24	2	855-401	Linear Shaft Base
25	4	858-250	1 1/4" x 1 1/2" x 1/2" Rubber Donut
26	12	858-252	2 1/2"OD x 1"ID RUBBER DOUGHNUT - 1/2"

<p>This document contains information proprietary to Magnum Fitness Systems. It is submitted in confidence and is to be used solely for the purpose for which it is furnished. This document and such information is not to be reproduced, transmitted, or used in whole or part without written authorization.</p>	<p>TOLERANCES: + 0.000" - 1/16"</p>		<p>MAGNUM FITNESS SYSTEMS 2201 12th. Avenue S. Milwaukee, WI, 53172</p>			
	<p>UNLESS OTHERWISE SPECIFIED DIMENSIONS ARE IN INCHES.</p>		<p>TITLE: M49 - Angled Smith Press</p>			
<p>DRAWN BY: Josh Ellis</p>	<p>DATE: 03/13/06</p>	<p>PART NO. xxx-xxx</p>	<p>JOB NO. XXXXXXXX</p>	<p>REV: 1</p>		
<p>FILE LOCATION: C:\Cad Drawings\Solid Works\</p>					<p>2 OF 2</p>	