

ITEM NO.	QTY.	PART NO.	DESCRIPTION
1	1	100-743	Main Frame
2	1	100-745	Arm
3	1	100-744	Weight Arm
4	1	100-568	Handles
5	2	851-509	1"ID x 1 1/4"OD BUSHING
6	4	851-317	1" PILLOW BLOCK
7	1	858-260	2" x 2" RUBBER BUMMPER
8	5	850-004	2" x 2" END CAP
9	1	858-400	Cane Tip
10	1	850-003	1 1/2" x 1 1/2" END CAP
11	1	850-010	1 1/2" X 2" END CAP
12	1	339-713	Seat Post
13	1	900-038	UPHOLSTERY
14	6	819-316	1" Ext. SNAP RING
15	5	850-012	1" Vinyl Cap
16	1	858-252	2 1/2"OD x 1"ID RUBBER DOUGHNUT - 1/2"
17	1	858-253	2 1/2"OD x 1 7/8"ID RUBBER BUMPER - 1/2"
18	1	850-030	Bullet End Cap
19	1	819-530	5/16" Roll Pin
20	1	900-036	ARM PAD
21	1	900-040L	Small Arm Pad (Left)
22	1	900-040r	Small Arm Pad (Right)
23	1	101-411	Lever Lock Assembly

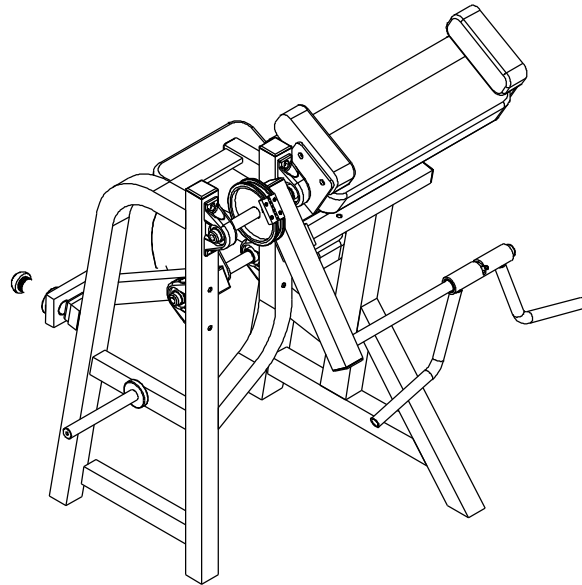

<p>This document contains information proprietary to Magnum Fitness Systems. It is submitted in confidence and is to be used solely for the purpose for which it is furnished. This document and such information is not to be reproduced, transmitted, or used in whole or part without written authorization.</p>	<p><b>TOLERANCES:</b> + 0.000" - 1/16"</p>		<p><b>MAGNUM FITNESS SYSTEMS</b> 2201 12th. Avenue S. Milwaukee, WI, 53172</p>	
	<p>UNLESS OTHERWISE SPECIFIED DIMENSIONS ARE IN INCHES.</p>		<p>TITLE: 431 - Bicep Curl</p>	
<p>DRAWN BY: Josh Ellis</p>	<p>DATE: 08/17/07</p>	<p>PART NO. xxx-xxx</p>	<p>JOB NO. XXXXXXXX</p>	<p>REV: 1</p>
<p>FILE LOCATION: C:\Cad Drawings\Solid Works\</p>				<p>1 OF 2</p>

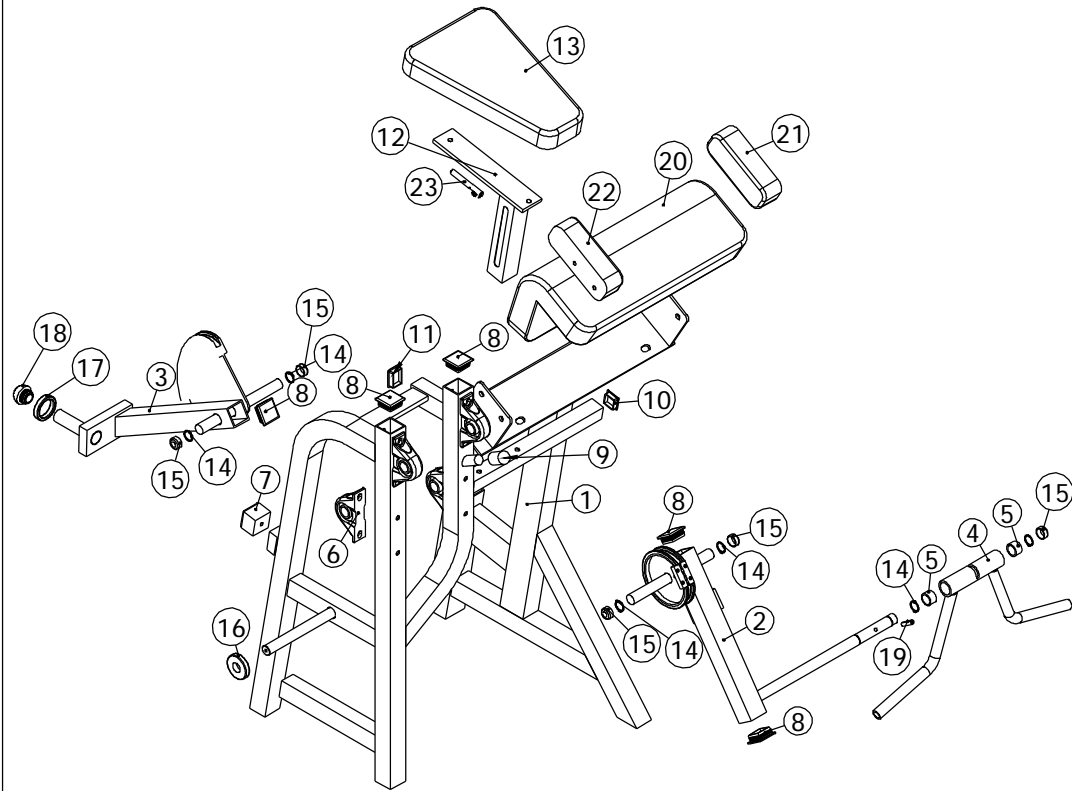

This document contains information proprietary to Magnum Fitness Systems. It is submitted in confidence and is to be used solely for the purpose for which it is furnished. This document and such information is not to be reproduced, transmitted, or used in whole or part without written authorization.

TOLERANCES: + 0.000"  
- 1/16"

**MAGNUM FITNESS SYSTEMS**  
2201 12th. Avenue  
S. Milwaukee, WI, 53172

UNLESS OTHERWISE SPECIFIED  
DIMENSIONS ARE IN INCHES.

TITLE: 431 - Bicep Curl

DRAWN BY:  
Josh Ellis

DATE:  
08/17/07

PART NO.  
xxx-xxx

JOB NO.  
XXXXXXXX

REV:  
1

FILE LOCATION: C:\Cad Drawings\Solid Works\

2 OF 2