

This document contains information proprietary to Magnum Fitness Systems. It is submitted in confidence and is to be used solely for the purpose for which it is furnished. This document and such information is not to be reproduced, transmitted, or used in whole or part without written authorization.

TOLERANCES: + 0.000"
- 1/16"

MAGNUM FITNESS SYSTEMS
2201 12th. Avenue
S. Milwaukee, WI, 53172

UNLESS OTHERWISE SPECIFIED
DIMENSIONS ARE IN INCHES.

TITLE: 400 - Perfect Squat

DRAWN BY:
Josh Ellis

DATE:
08/29/07

PART NO.
xxx-xxx

JOB NO.
XXXXXXXX

REV:
1

FILE LOCATION: C:\Cad Drawings\Solid Works\

1 OF 2

ITEM NO.	QTY.	PART NO.	DESCRIPTION
1	1	100-714	Main Frame
2	7	851-317	1" PILLOW BLOCK
3	1	100-719	Counter Weight Arm
4	1	100-715	Weight Arm
5	1	100-716	Pivot Arm
6	6	851-416	FLANGE BEARING - 1"
7	1	100-717	Telescopic Slide
8	1	339-821	Chrome Slide
9	1	100-720	Shoulder Rest
10	2	851-506	1" ID Flange Bushing
11	1	100-718	Stop
12	4	200-193	1" CRR - 5 1/4"
13	1	200-192	1" CRR - 4 1/4"
14	16	819-316	1" Ext. SNAP RING
15	9	850-004	2" x 2" END CAP
16	3	850-011	1 1/2" x 3" END CAP
17	16	850-012	1" Vinyl Cap
18	2	858-260	2" x 2" RUBBER BUMPER
19	2	838-223	HALF-ROUND RUBBER BUMPER
20	2	858-253	2 1/2"OD x 1 7/8"ID RUBBER BUMPER - 1/2"
21	2	850-030	Bullet End Cap
22	2	858-252	2 1/2"OD x 1"ID RUBBER DOUGHNUT - 1/2"
23	2	900-181	Shoulder Pad
24	1	500-657	Foot Plate
25	1	200-203	8" CRR - 3 1/4"
26	2	850-035	2" ROUND END CAP
27	1	101-140	SPRING PIN ASSEMBLY

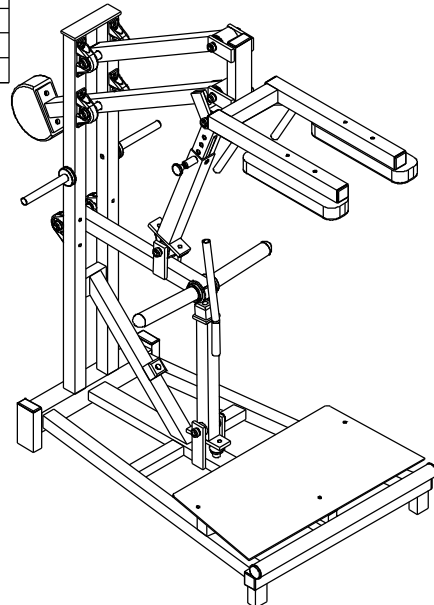

<p>This document contains information proprietary to Magnum Fitness Systems. It is submitted in confidence and is to be used solely for the purpose for which it is furnished. This document and such information is not to be reproduced, transmitted, or used in whole or part without written authorization.</p>	<p>TOLERANCES: + 0.000" - 1/16"</p>		<p>MAGNUM FITNESS SYSTEMS 2201 12th. Avenue S. Milwaukee, WI, 53172</p>	
	<p>UNLESS OTHERWISE SPECIFIED DIMENSIONS ARE IN INCHES.</p>		<p>TITLE: 400 - Perfect Squat</p>	
<p>DRAWN BY: Josh Ellis</p>	<p>DATE: 08/29/07</p>	<p>PART NO. xxx-xxx</p>	<p>JOB NO. XXXXXXXX</p>	<p>REV: 1</p>
<p>FILE LOCATION: C:\Cad Drawings\Solid Works\</p>			<p>2 OF 2</p>	