

ITEM NO.	QTY.	PART NO.	DESCRIPTION
1	1	100-676	MAIN FRAME
2	1	100-677	SEAT BACK
3	1	100-507	SEAT FRAME
4	1	100-678	ADJUSTMENT TUBE
5	1	100-321	SEAT BACK ADJUSTER POST
6	1	339-734	SEAT BACK ADJUSTMENT TUBE
7	1	900-065	SEAT PAD
8	1	900-066	BACK PAD
9	1	339-735	SEAT ADJUSTMENT TUBE
12	1	836-202	SEAT TRAY
13	1	836-201	BACK TRAY
14	2	101-140	SPRING PIN ASSEMBLY
15	2	101-139	3 1/2" WHEEL ASSEMBLY

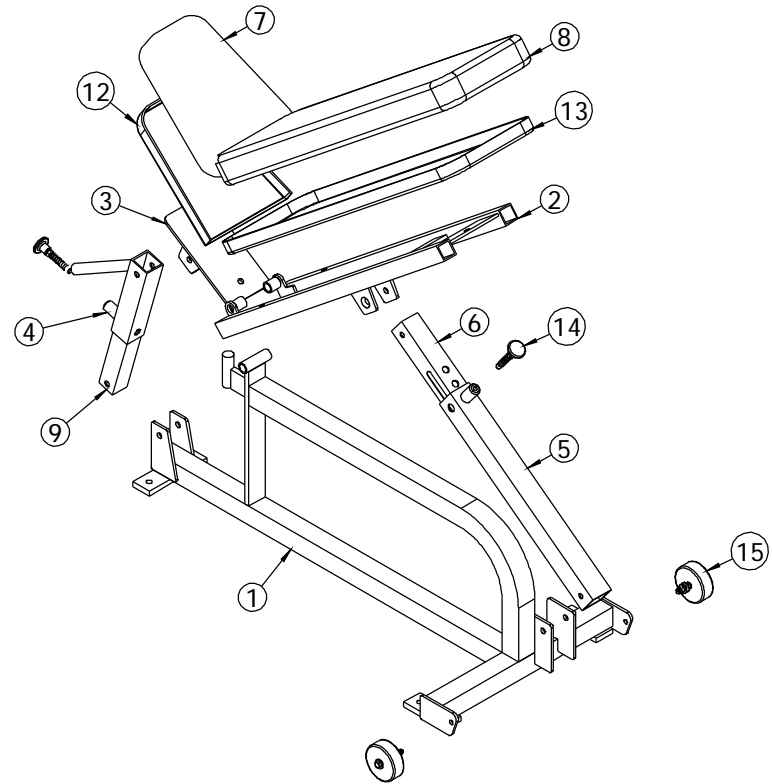

<p>This document contains information proprietary to Magnum Fitness Systems. It is submitted in confidence and is to be used solely for the purpose for which it is furnished. This document and such information is not to be reproduced, transmitted, or used in whole or part without written authorization.</p>	<p>TOLERANCES: + 0.000" - 1/16"</p>	<p>MAGNUM FITNESS SYSTEMS 2201 12th. Avenue S. Milwaukee, WI, 53172</p>		
	<p>UNLESS OTHERWISE SPECIFIED DIMENSIONS ARE IN INCHES.</p>	<p>TITLE: M85 v 1.0 FLAT TO INCLINE BENCH WITH WHEELS</p>		
<p>DRAWN BY: J. Wenzel</p>	<p>DATE: 07/02/04</p>	<p>PART NO. XXX-XXX</p>	<p>JOB NO. XXXXXXXX</p>	<p>REV: 1</p>
<p>FILE LOCATION: C:\Cad Drawings\Solid Works\</p>				<p>1 OF 1</p>