

This document contains information proprietary to Magnum Fitness Systems. It is submitted in confidence and is to be used solely for the purpose for which it is furnished. This document and such information is not to be reproduced, transmitted, or used in whole or part without written authorization.

TOLERANCES: + 0.000"
- 1/16"

UNLESS OTHERWISE SPECIFIED
DIMENSIONS ARE IN INCHES.

DRAWN BY:
Josh Ellis

MAGNUM FITNESS SYSTEMS

2201 12th. Avenue
S. Milwaukee, Wi, 53172

TITLE: A86 - Flat / Incline / Decline Bench

DATE:
06/30/10

PART NO.
XXX-XXX

JOB NO.
XXXXXXXX

REV:
1

ITEM NO.	PART NUMBER	DESCRIPTION	QTY.
1	102-031	Main Frame Bottom	1
2	102-032	Roller Frame	1
3	102-033	Telescopic Slide	1
4	339-110	1 3/4" x 1 3/4" TUBE - 10"	1
5	102-034	Adjustment Frame	1
6	339-107	1/4" PLASMA	2
7	102-035	Seat Frame	1
8	838-223	HALF-ROUND RUBBER BUMPER	2
9	A86-pad-1	Seat Pad	1
10	836-215	ROLLER END CAP w/ 2" HOLE	2
11	836-216	ROLLER END CAP w/ 5/16" HOLE	2
12	902-007	9" FOAM ROLLER	2
13	A85 back pad	Back Pad	1
14	Preferred Wide FW 0.4375		16
15	Preferred Wide FW 0.3125		8
16	HFBOLT 0.5-13x4x1.25-N		3
17	HFBOLT 0.5-13x4.5x1.25-N		1
18	HFBOLT 0.5-13x7.5x1.25-N		1
19	HFBOLT 0.5-13x3.5x1.25-N		1
20	HFBOLT 0.5-13x3.25x1.25-N		1
21	HFBOLT 0.3125-18x3x0.875-N		6
22	HFBOLT 0.3125-18x1x1-N		2
23	HJNUT 0.5000-13-D-N		7
24	HJNUT 0.3125-18-D-N		2
25	851-514	1/2" BRASS BUSHING	8
26	Preferred Narrow FW 0.4375		2
27	850-061	3" Hex Foot	4
28	101-140	SPRING PIN ASSEMBLY	1
29	850-004	2" x 2" END CAP	8
30	850-010	1 1/2" X 2" END CAP	2
31	815-508	5/16" SET SCREW - 3/4"	2
32	852-813	Ball Joint	2
33	HJNUT 0.3125-18-D-N		2
34	852-826A	SHOCK	1
35	852-826B	SHOCK	1
36	102-731	2 1/2" WHEEL ASSEMBLY (2 1/2" Wheel - 850-507)	2
37	700-538	1" ID Grip - 3" Long - Cut From 10" Grip (858-300)	1

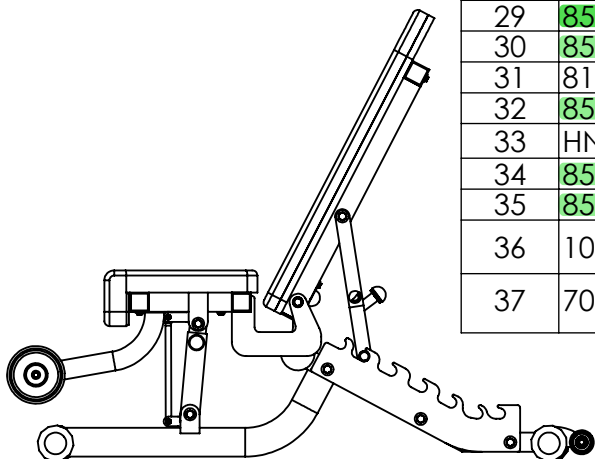
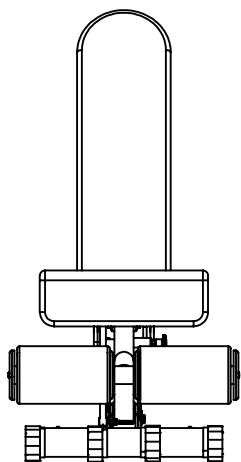

This document contains information proprietary to Magnum Fitness Systems. It is submitted in confidence and is to be used solely for the purpose for which it is furnished. This document and such information is not to be reproduced, transmitted, or used in whole or part without written authorization.

TOLERANCES: + 0.000"
- 1/16"

UNLESS OTHERWISE SPECIFIED
DIMENSIONS ARE IN INCHES.

DRAWN BY:
Josh Ellis

MAGNUM FITNESS SYSTEMS
2201 12th. Avenue
S. Milwaukee, Wi, 53172
TITLE: A86 - Flat / Incline / Decline Bench

DATE: 06/30/10	PART NO. XXX-XXX	JOB NO. XXXXXXXXXX	REV: 1
-------------------	---------------------	-----------------------	-----------