

This document contains information proprietary to Magnum Fitness Systems. It is submitted in confidence and is to be used solely for the purpose for which it is furnished. This document and such information is not to be reproduced, transmitted, or used in whole or part without written authorization.

TOLERANCES: + 0.000"
- 1/16"

MAGNUM FITNESS SYSTEMS

2201 12th. Avenue
S. Milwaukee, WI, 53172

TITLE: 4022 - Vertical Bench Press

UNLESS OTHERWISE SPECIFIED
DIMENSIONS ARE IN INCHES.

DRAWN BY:
Josh Ellis

DATE:
03/01/06

PART NO.
xxx-xxx

JOB NO.
XXXXXXXX

REV:
1

FILE LOCATION: C:\Cad Drawings\Solid Works\

1 OF 2

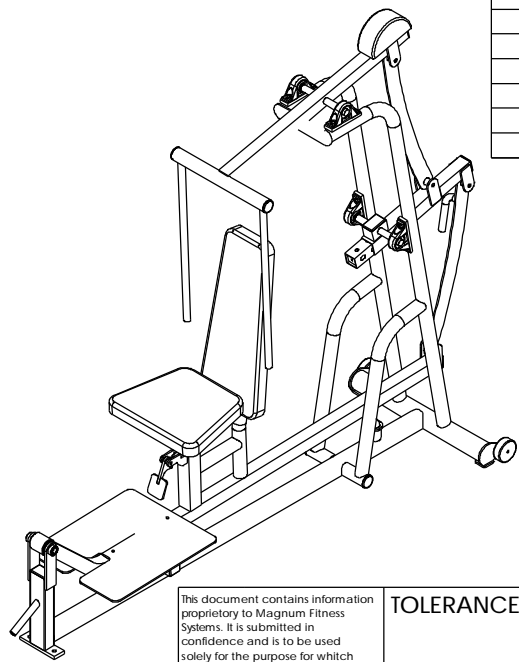

ITEM NO.	QTY.	PART NO.	DESCRIPTION
1	4	851-317	1" PILLOW BLOCK
2	1	101-511	Sub Frame
3	1	101-507	User Arms
4	1	101-510	Slide Housing
5	1	101-474	Slide
6	1	101-514	Main Frame
7	1	101-517	Upper Linkage
8	1	101-516	Lower Linkage
9	5	850-004	2" x 2" END CAP
10	1	339-702	ADJUSTMENT POST - CHROMED
11	1	852-826	SHOCK
12	1	901-030	UPHOLSTERY
13	1	901-054	UPHOLSTERY
14	1	101-513	Lever
15	2	851-552	3/8" FLANGE BUSHING - 3/8"
16	2	850-006	2" X 3" END CAP
17	5	850-044	2" ROUND END CAP
18	1	501-537	DIAMOND PLATE
19	2	851-416	FLANGE BEARING - 1"
20	1	838-228	HALF-ROUND RUBBER BUMPER
21	2	850-504	3 1/2" WHEEL
22	1	101-140	SPRING PIN ASSEMBLY
23	1	852-807	SPRING
24	1	855-302	SPRING PIN w/ 5/32"
25	1	817-306	3/8"-16 JAM NUT
26	1	700-534	MASTER LINK
27	8	851-514	1/2" BRASS BUSHING
28	1	200-455	8" CRR - 3 1/4"
NP	2	858-322	GRIP - 30"
NP	1	858-300	GRIP - 10"
NP	1	858-301	GRIP - 10" - RED

This document contains information proprietary to Magnum Fitness Systems. It is submitted in confidence and is to be used solely for the purpose for which it is furnished. This document and such information is not to be reproduced, transmitted, or used in whole or part without written authorization.

TOLERANCES: + 0.000"
- 1/16"

UNLESS OTHERWISE SPECIFIED
DIMENSIONS ARE IN INCHES.

MAGNUM FITNESS SYSTEMS
2201 12th. Avenue
S. Milwaukee, WI, 53172

TITLE: 4022 - Vertical Bench Press

DRAWN BY:
Josh Ellis

DATE:
03/01/06

PART NO.
xxx-xxx

JOB NO.
XXXXXXXX

REV:
1

FILE LOCATION: C:\Cad Drawings\Solid Works\

2 OF 2