

This document contains information proprietary to Magnum Fitness Systems. It is submitted in confidence and is to be used solely for the purpose for which it is furnished. This document and such information is not to be reproduced, transmitted, or used in whole or part without written authorization.

TOLERANCES: + 0.000"  
- 1/16"

UNLESS OTHERWISE SPECIFIED  
DIMENSIONS ARE IN INCHES.

DRAWN BY:  
Josh Ellis

**MAGNUM FITNESS SYSTEMS**

2201 12th. Avenue  
S. Milwaukee, WI, 53172

4021 - Lat Pulldown

DATE:  
02/22/06

PART NO.  
xxx-xxx

JOB NO.  
XXXXXXXX

REV:  
1

FILE LOCATION: C:\Cad Drawings\Solid Works\

1 OF 2

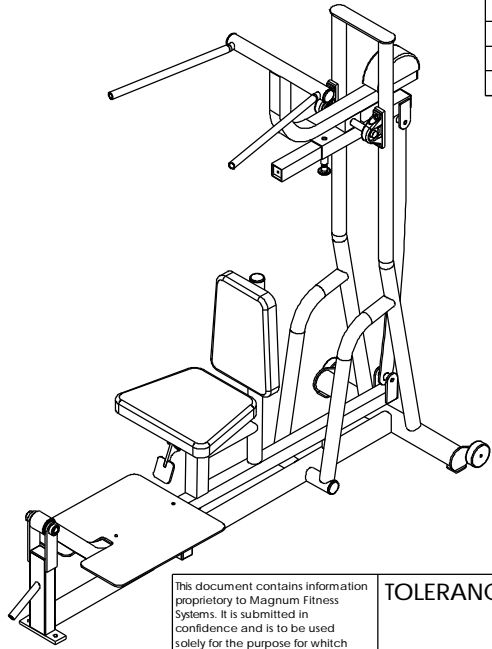

ITEM NO.	QTY.	PART NO.	DESCRIPTION
1	1	101-422	Main Frame
2	1	101-420	Sub Frame
3	1	101-426	Linkage
4	1	101-427	User Arms
5	1	101-428	Slide
6	2	851-317	1" PILLOW BLOCK
7	1	339-702	ADJUSTMENT POST - CHROMED
8	1	901-054	UPHOLSTERY
9	1	901-055	UPHOLSTERY
10	1	501-537	DIAMOND PLATE
11	1	200-455	8" CRR - 3 1/4"
12	5	850-044	2" ROUND END CAP
13	1	850-006	2" X 3" END CAP
14	5	850-004	2" x 2" END CAP
15	2	850-504	3 1/2" WHEEL
16	1	838-223	HALF-ROUND RUBBER BUMPER
17	4	851-514	1/2" BRASS BUSHING
18	2	851-416	FLANGE BEARING - 1"
19	1	101-513	Lever
20	2	851-552	3/8" FLANGE BUSHING - 3/8"
21	1	101-140	SPRING PIN ASSEMBLY
NP	2	858-322	Grip - 30"
NP	1	858-300	Grip - 10"
NP	1	858-301	Grip - 10" - Red
22	1	855-302	SPRING PIN w/ 5/32"
23	1	852-807	SPRING
24	1	817-306	3/8"-16 JAM NUT
25	1	700-534	MASTER LINK
26	1	852-826	SHOCK

This document contains information proprietary to Magnum Fitness Systems. It is submitted in confidence and is to be used solely for the purpose for which it is furnished. This document and such information is not to be reproduced, transmitted, or used in whole or part without written authorization.

TOLERANCES: + 0.000"  
- 1/16"

UNLESS OTHERWISE SPECIFIED  
DIMENSIONS ARE IN INCHES.

DRAWN BY:  
Josh Ellis

**MAGNUM FITNESS SYSTEMS**  
2201 12th. Avenue  
S. Milwaukee, WI, 53172

TITLE: 4021 - Lat Pulldown

DATE: 02/22/06	PART NO. xxx-xxx	JOB NO. XXXXXXXX	REV: 1
-------------------	---------------------	---------------------	-----------

FILE LOCATION: C:\Cad Drawings\Solid Works\

2 OF 2