

This document contains information proprietary to Magnum Fitness Systems. It is submitted in confidence and is to be used solely for the purpose for which it is furnished. This document and such information is not to be reproduced, transmitted, or used in whole or part without written authorization.

TOLERANCES: + 0.000"  
- 1/16"

**MAGNUM FITNESS SYSTEMS**

2201 12th. Avenue  
S. Milwaukee, WI, 53172

TITLE: 4020 - Lat Row

UNLESS OTHERWISE SPECIFIED  
DIMENSIONS ARE IN INCHES.

DRAWN BY:  
Josh Ellis

DATE:  
02/23/06

PART NO.  
xxx-xxx

JOB NO.  
XXXXXXXX

REV:  
1

FILE LOCATION: C:\Cad Drawings\Solid Works\

1 OF 2

ITEM NO.	QTY.	PART NO.	DESCRIPTION
1	1	101-470	Main Frame
2	1	101-471	Sub Frame
3	1	101-472	Pulley Housing and Slide Assembly
4	2	851-317	1" PILLOW BLOCK
5	1	101-473	Linkage
6	1	101-474	Slide
7	1	900-195	UPHOLSTERY
8	1	501-568	DIAMOND PLATE
9	2	851-416	FLANGE BEARING - 1"
10	1	200-191	1" CRR - 5"
11	1	838-226	HALF-ROUND RUBBER BUMPER
12	4	853-303	4" CABLE PULLEY - 3/8" NARROW HOLE
13	9	850-004	2" x 2" END CAP
14	3	850-044	2" ROUND END CAP
15	1	850-006	2" X 3" END CAP
16	6	851-514	1/2" BRASS BUSHING
17	2	850-504	3 1/2" WHEEL
18	1	101-475	CABLE CLIP - CENTERED
19	1	339-714	1/2" x 1 1/2" F.S. - 2 1/4"
20	1	901-060	Head Pad
21	1	101-140	SPRING PIN ASSEMBLY
NP	1	858-300	GRIP - 10"
NP	1	858-301	GRIP - 10" - RED

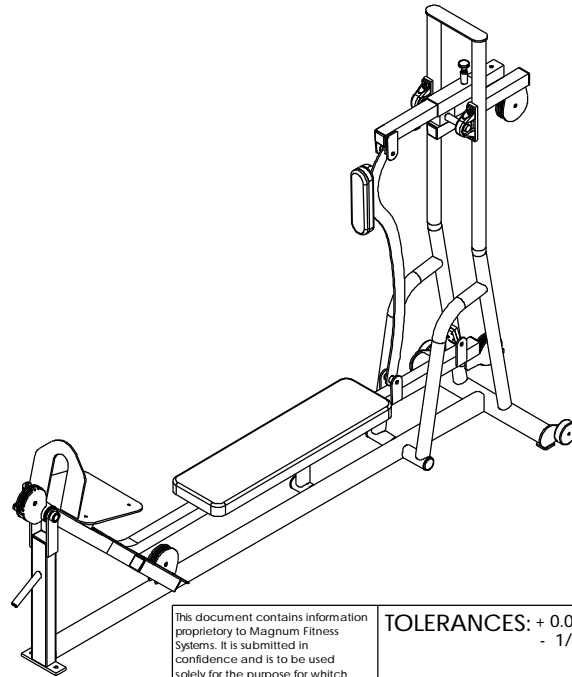

This document contains information proprietary to Magnum Fitness Systems. It is submitted in confidence and is to be used solely for the purpose for which it is furnished. This document and such information is not to be reproduced, transmitted, or used in whole or part without written authorization.

TOLERANCES: + 0.000"  
- 1/16"

UNLESS OTHERWISE SPECIFIED  
DIMENSIONS ARE IN INCHES.

DRAWN BY:  
Josh Ellis

DATE:  
02/23/06

PART NO.  
xxx-xxx

JOB NO.  
XXXXXXXX

REV:  
1

**MAGNUM FITNESS SYSTEMS**

2201 12th. Avenue  
S. Milwaukee, WI, 53172

TITLE: 4020 - Lat Row

FILE LOCATION: C:\Cad Drawings\Solid Works\

2 OF 2