

This document contains information proprietary to Magnum Fitness Systems. It is submitted in confidence and is to be used solely for the purpose for which it is furnished. This document and such information is not to be reproduced, transmitted, or used in whole or part without written authorization.

TOLERANCES: + 0.000"
- 1/16"

UNLESS OTHERWISE SPECIFIED
DIMENSIONS ARE IN INCHES.

DRAWN BY:
Josh Ellis

DATE:
02/17/06

PART NO.
xxx-xxx

JOB NO.
XXXXXXXXX

REV:
1

MAGNUM FITNESS SYSTEMS

2201 12th. Avenue
S. Milwaukee, WI, 53172

TITLE: 4016 - Bench Press

FILE LOCATION: C:\Cad Drawings\Solid Works\

1 OF 2

ITEM NO.	QTY.	PART NO.	DESCRIPTION
1	1	101-412	Main Frame
2	1	101-413	Sub Frame
3	1	101-414	Linkage
4	1	101-415	Slide Sub Assembly
5	1	101-416	Arm
6	2	851-317	1" PILLOW BLOCK
7	1	838-223	HALF-ROUND RUBBER BUMPER
8	1	101-417	User Arms
9	1	101-418	Slide
10	1	339-052	3/16" PLASMA - CHROMED
11	1	901-053	3/4" UPHOLSTERY
12	2	200-191	1" CRR - 5"
13	2	851-416	FLANGE BEARING - 1"
14	4	850-044	2" ROUND END CAP
15	2	851-518	1"ID x 1 1/4OD" FLANGED BUSHING
16	4	851-514	1/2" BRASS BUSHING
17	1	850-006	2" X 3" END CAP
18	3	850-004	2" x 2" END CAP
19	2	855-302	SPRING PIN w/ 5/32"
20	2	852-807	SPRING
21	2	817-306	3/8"-16 JAM NUT
22	2	852-207	GOLD PULL KNOB
23	1	200-455	8" CRR - 3 1/4"
24	2	810-956	Bolt
25	2	850-504	3 1/2" WHEEL
NP	3	858-300	GRIP - 10"
NP	1	858-301	GRIP - 10" - RED

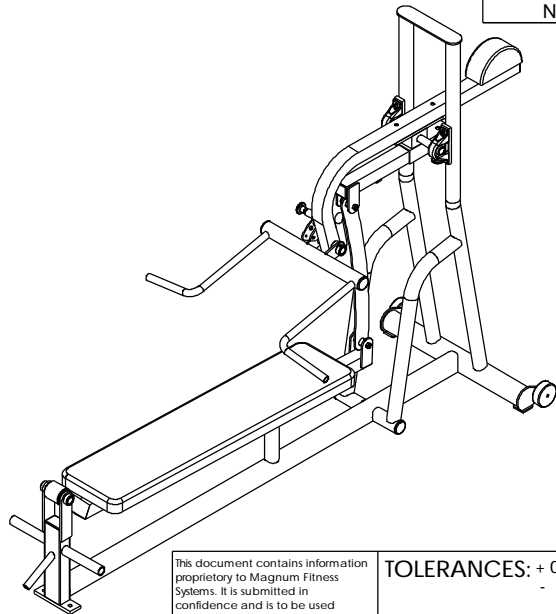

This document contains information proprietary to Magnum Fitness Systems. It is submitted in confidence and is to be used solely for the purpose for which it is furnished. This document and such information is not to be reproduced, transmitted, or used in whole or part without written authorization.

TOLERANCES: + 0.000"
- 1/16"

UNLESS OTHERWISE SPECIFIED
DIMENSIONS ARE IN INCHES.

DRAWN BY:
Josh Ellis

MAGNUM FITNESS SYSTEMS
2201 12th. Avenue
S. Milwaukee, WI, 53172

TITLE: 4016 - Bench Press

DATE: 02/17/06	PART NO. xxx-xxx	JOB NO. XXXXXXXX	REV: 1
-------------------	---------------------	---------------------	-----------

FILE LOCATION: C:\Cad Drawings\Solid Works\

2 OF 2