

This document contains information proprietary to Magnum Fitness Systems. It is submitted in confidence and is to be used solely for the purpose for which it is furnished. This document and such information is not to be reproduced, transmitted, or used in whole or part without written authorization.

TOLERANCES: + 0.000"
- 1/16"

UNLESS OTHERWISE SPECIFIED
DIMENSIONS ARE IN INCHES.

DRAWN BY:
Josh Ellis

MAGNUM FITNESS SYSTEMS
2201 12th. Avenue
S. Milwaukee, WI, 53172

TITLE: 4001 - Leg Extension

DATE:
01/30/06

PART NO.
xxx-xxx

JOB NO.
XXXXXXXX

REV:
1

FILE LOCATION: C:\Cad Drawings\Solid Works\

1 OF 2

ITEM NO.	QTY.	PART NO.	DESCRIPTION
1	1	101-452	Main Frame
2	1	101-453	Arm
3	1	101-456	Slide
4	1	101-457	4001 PIVOT LINKAGE
5	1	101-458	Linkage
6	2	851-317	1" PILLOW BLOCK
7	1	200-455	8" CRR - 3 1/4"
8	1	901-057	UPHOLSTERY
9	1	339-709	CHROME SEAT POST
10	1	900-183	UPHOLSTERY - BACK REST
11	1	101-454	Linkage
12	1	101-455	Leg Swivel
13	2	902-007	9" ROLLER PAD
14	2	836-216	ROLLER END CAP w/ 5/16" HOLE
15	4	850-035	2" ROUND END CAP
16	2	850-006	2" X 3" END CAP
17	3	850-010	1 1/2" X 2" END CAP
18	5	850-004	2" x 2" END CAP
19	3	853-308	4" CABLE PULLEY - 3/8" HOLE
20	1	101-475	CABLE CLIP - CENTERED
21	10	851-514	1/2" BRASS BUSHING
22	1	339-714	1/2" x 1 1/2" F.S. - 2 1/4"
23	1	853-303	4" CABLE PULLEY - 3/8" NARROW HOLE
24	2	851-416	FLANGE BEARING - 1"
25	2	850-504	3 1/2" WHEEL
26	2	836-215	ROLLER END CAP w/ 2" HOLE
27	2	101-140	SPRING PIN ASSEMBLY
28	3	838-223	HALF-ROUND RUBBER BUMPER
29	1	300-194	1/2" x 2" F.S. - 1"
30	1	851-504	5/8" OD Oil Lube Bushing
NP	3	858-300	10" Grip - Black
NP	1	858-301	10" Grip - Red

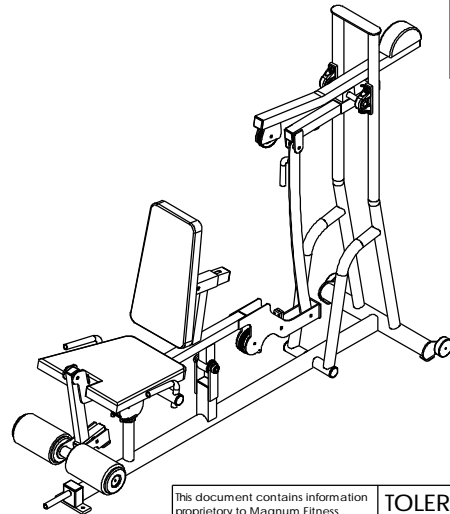

This document contains information proprietary to Magnum Fitness Systems. It is submitted in confidence and is to be used solely for the purpose for which it is furnished. This document and such information is not to be reproduced, transmitted, or used in whole or part without written authorization.

TOLERANCES: + 0.000"
- 1/16"

UNLESS OTHERWISE SPECIFIED
DIMENSIONS ARE IN INCHES.

DRAWN BY:
Josh Ellis

DATE:
01/30/06

PART NO.
xxx-xxx

JOB NO.
XXXXXXXX

REV:
1

MAGNUM FITNESS SYSTEMS

2201 12th. Avenue
S. Milwaukee, WI, 53172

TITLE: 4001 - Leg Extension

FILE LOCATION: C:\Cad Drawings\Solid Works\

2 OF 2