

This document contains information proprietary to Magnum Fitness Systems. It is submitted in confidence and is to be used solely for the purpose for which it is furnished. This document and such information is not to be reproduced, transmitted, or used in whole or part without written authorization.

TOLERANCES: + 0.000"
- 1/16"

MAGNUM FITNESS SYSTEMS
2201 12th. Avenue
S. Milwaukee, WI, 53172

UNLESS OTHERWISE SPECIFIED
DIMENSIONS ARE IN INCHES.

TITLE: 4000 - Leg Press

DRAWN BY:
Josh Ellis

DATE:
01/19/06

PART NO.
XXX-XXX

JOB NO.
XXXXXXXX

REV:
1

FILE LOCATION: C:\Cad Drawings\Solid Works\

1 OF 2

ITEM NO.	QTY.	PART NO.	DESCRIPTION
1	1	101-476	4000 MAIN FRAME
2	1	101-477	4000 SUB FRAME
3	1	101-478	4000 ARM
4	1	101-479	4000 SLED
5	1	101-480	4000 BEARING TUBE
6	1	101-481	CHROME SLIDE
7	2	851-317	1" PILLOW BLOCK
8	1	200-455	8" CRR - 3 1/4"
9	1	339-709	CHROME SEAT POST
10	1	900-183	UPHOLSTERY - BACK REST
11	1	901-063	UPHOLSTERY
12	1	501-596	3/16" DIAMOND PLATE
13	3	853-303	4" CABLE PULLEY - 3/8" NARROW HOLE
14	4	850-035	2" ROUND END CAP
15	12	850-004	2" x 2" END CAP
16	4	852-717	1" SPLIT COLLAR
17	2	858-252	2 1/2"OD x 1"ID RUBBER DOUGHNUT - 1/2"
18	2	851-033	1" LINEAR SHAFT - 33"
19	2	851-416	FLANGE BEARING - 1"
20	1	101-482	CABLE CLIP - OFFSET
21	2	101-475	CABLE CLIP - CENTERED
22	6	851-514	1/2" BRASS BUSHING
23	3	851-203	1" LINEAR SHAFT BEARING
24	2	850-504	3 1/2" WHEEL
25	2	101-140	SPRING PIN ASSEMBLY
26	4	339-714	1/2" x 1 1/2" F.S. - 2 1/4"
27	1	858-223	HALF-ROUND RUBBER BUMPER
28	1	853-301	3/8" HOLE PULLEY
NP	3	858-300	10" BLACK GRIP
NP	1	858-301	10" RED GRIP

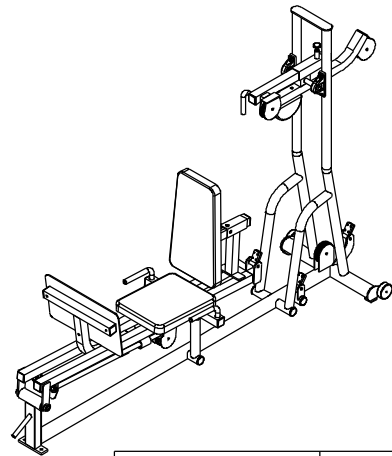

This document contains information proprietary to Magnum Fitness Systems. It is submitted in confidence and is to be used solely for the purpose for which it is furnished. This document and such information is not to be reproduced, transmitted, or used in whole or part without written authorization.

TOLERANCES: + 0.000"
- 1/16"

UNLESS OTHERWISE SPECIFIED
DIMENSIONS ARE IN INCHES.

DRAWN BY:
Josh Ellis

MAGNUM FITNESS SYSTEMS

2201 12th. Avenue
S. Milwaukee, WI, 53172

TITLE: XXX

DATE: 01/19/06	PART NO. XXX-XXX	JOB NO. XXXXXXXX	REV: 1
-------------------	---------------------	---------------------	-----------

FILE LOCATION: C:\Cad Drawings\Solid Works\

2 OF 2