

REVISION HISTORY				
REV	DATE	DESCRIPTION	ECO	BY
A	05/18/09	PRODUCTION RELEASE		CSM

ITEM NO.	PART NUMBER	DESCRIPTION	Default QTY.
1	0211-0143	ASSY WELD MAIN FRAME, PR S2301	1
2	0211-0141	ASSY WELD HANDLES, S2301	1
3	0211-0142	ASSY WELD LEVERAGE ARM, S2301	1
4	0211-0228	ASSY WELD LINEAR ROM ADJ OUTER	1
5	0210-0348	ASSY WELD SEAT POST, 20"	1
6	4900-PNTX	POWDER COAT, TBD	2.00 LBS.
7	3500-0025	ASSY UPHOLSTRY 1.78 X 8 7/8 FC 202-C	1
8	3500-0049	ASSY UPHOLSTRY, 10A34, FS-400-A	1

ITEM NO.	PART NUMBER	DESCRIPTION	Default QTY.
9	4900-UPHX	UPHOLSTRY, TBD	1.5 LIN. YDS.

ITEM NO.	PART NUMBER	DESCRIPTION	Default QTY.
10	1400-0000	TUBE 1.50 OD, 1.25 ID, RUBBER, BLK	10 IN.
11	2120-0154	PLATE, BELT CLAMP, 1/4, BC-002	2
12	2120-3826	CAP, BEARING, 2 1/2 RND ALUM	2

ITEM NO.	PART NUMBER	DESCRIPTION	Default QTY.
13	2120-3876	CAP, HANDLE, 1 1/4	1
14	2120-3877	RING, HANDLE, 1 1/4	2
15	2120-4021	SHAFT, INC. PRESS ARM	1
16	2130-0066	COVER, PULLEY, 5"	3
17	2210-0009	BUSHING, SEAT POST	1
18	2411-0229	ASSY WELD LINEAR ROM ADJ INNER	1
19	2790-0001	ASSY WELDMENT, HANDLE	1
20	4210-0030	FHSCS, 3/8-16 X 875, BRIGHT, Z	2
21	4230-0005	SHCS, 1/4-20 X 1.0	4
22	4230-0059	BHSCS, 3/8-16 X 4 1/4, BRIGHT, Z	3
23	4230-0060	BHSCS, 3/8-16 X 2 3/4, BRIGHT, Z	2
24	4230-0069	BHSCS, 1/4-20 X 3 3/4, BRIGHT, Z	1
25	4230-0071	BHSCS, 1/2-13 X 3, BRIGHT, Z	1
26	4230-0076	BHSCS, 1/2-13 X 4 3/4, BRIGHT, Z	1
27	4230-0083	BHSCS, 5/16-18 X 1 1/4, BRIGHT, Z	8
28	4230-0093	BHSCS, 1/4-20 X 3/4, BRIGHT, Z	2
29	4250-0001	SSS, 10-32 X 1/8, BLK	8
30	4250-0015	SSSCP, 1/4-20 X 1/2, BLK	2
31	4500-0001	NUT, HEX, JAM, 5/8-18, ZINC	1
32	4500-0008	Nut, JAM, 1/4-20, Z	1
33	4500-0029	NUT NYLOC, JAM, 3/8-16, Z	5
34	4500-0004	NUT NYLOC, 1/2-20	1
35	4600-0007	WASHER, SAE, 5/16, Z	8
36	4600-0008	WASHER, SAE, 1/2, Z	3
37	4600-0009	WASHER, SAE, 3/8-16, Z	10
38	4600-0025	MACHINE BUSHING, 1" 1/8 GAGE	1
39	4800-0001	BELT, MECTROL, SPOOL	160 IN.
40	4900-0004	ROD END, 5/8, 1/8	2
41	4900-0052	SPRING, O.D. 5.115, CENTURY 901	1
42	4900-0088	CAP, BLACK, 1" ROUND	2
43	4900-0108	SLEEVE, HANDLE, RED	1
44	4900-0139	BEARING, 1 ID X 2 OD, NR16-Z	4
45	4900-0241	Pin/Pin, 3/8, K:100PP	1
46	4900-0441	PULLEY, BELT, 4.750 ID, 1.500 MANDIBED	2
47	5220-0002	LABEL, SAFETY, KEEP HANDS, SMALL	1
48	5220-0005	LABEL, SAFETY, SECURE TO FLOOR	1
49	5220-0028	LABEL, SAFETY, PINCH POINTS	1
50	5290-0001	SERIAL NUMBER	1
51	730-0913	BUMPER	1
52	4900-0588	CAP, 2.0 X 2.0, BLACK, TEXTURED	2
53	4230-0107	BHC, 5/8-11, 2.25, SHC, AS, B2	2
54	0311-0313	ASSY MECH WT FRAME, S2301 MS	1

- NOTES:
1. INTERPRET DRAWING PER ASME Y14.5M-1994
 2. IF APPLICABLE, CRITICAL DIMENSIONS LABELED.
 3. ALL HARDWARE IS KITTED PER 3700-0475.
 4. ALL UPHOLSTERY IS KITTED PER 3700-0094
 5. EST. GROSS WT. 586 LBS.

DOCUMENT STATUS:
ECO

	UNISEN INC. DBA 14410 Myford Road Irvine, CA 92606
	DRAWN: CSM CHECKED: CSM APPROVED: CSM
FINISH: N/A VENDOR: N/A	PART: NA SCALE: 1:10 SHEET 2 OF 2 SHEET SIZE: B

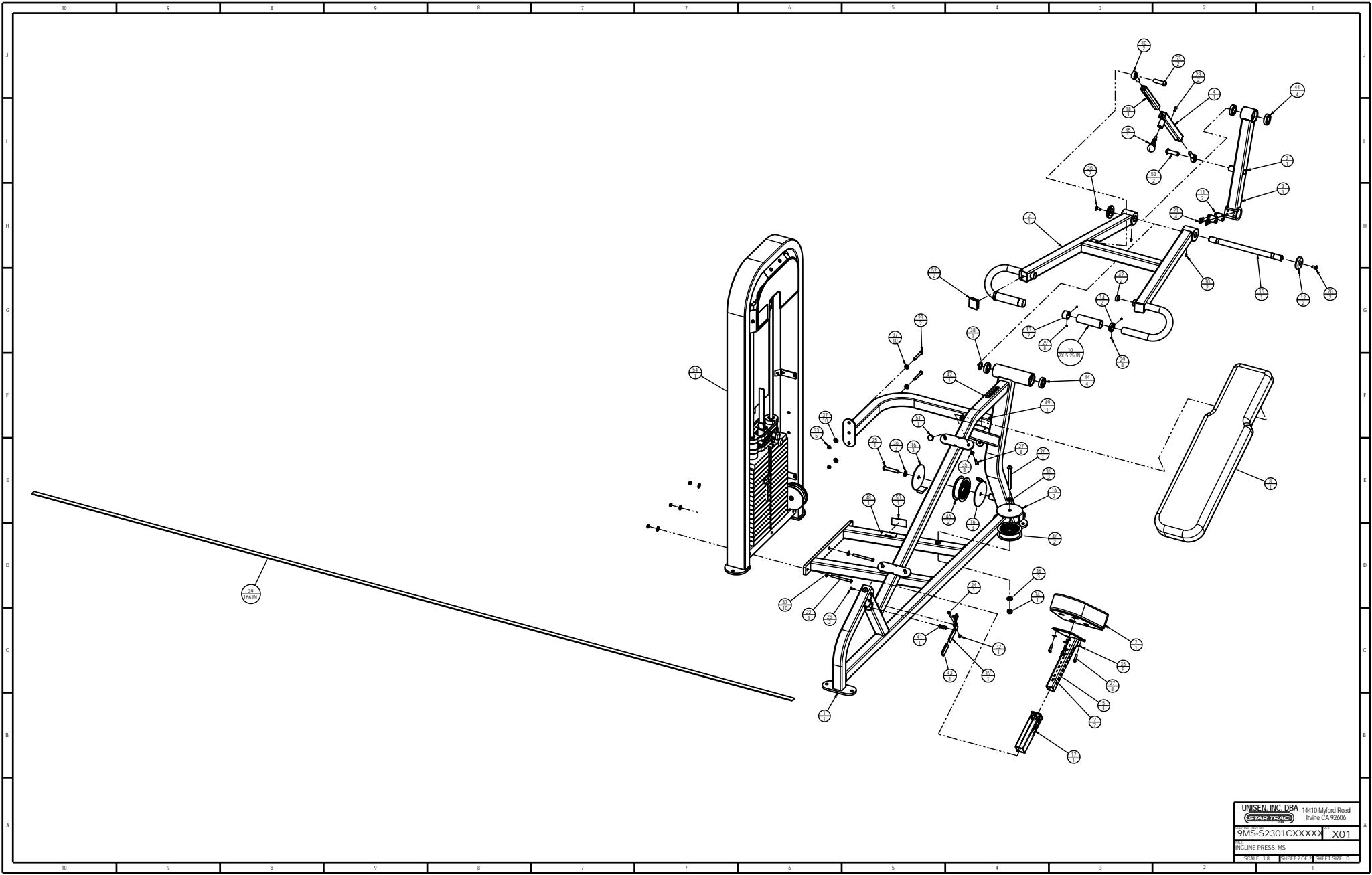

UNISEN, INC. DBA 14410 Myford Road
 STARTRAC Irvine, CA 92606
 9MS-52301CXXXXX X01
 INCLINE PRESS, MS
 SCALE: 1:8 SHEET 2 OF 2 SHEET SIZE: D