

REVISION HISTORY					
REV	DATE	DESCRIPTION	ECO	BY	
A	10/28/2008	PRODUCTION RELEASE	100336	JJJ	
B	12/19/08	CHANGED BELT LENGTHS	100380	MLB	

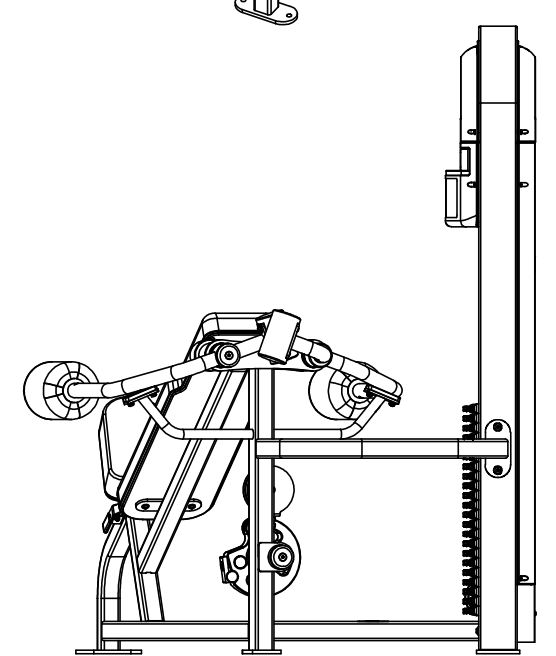
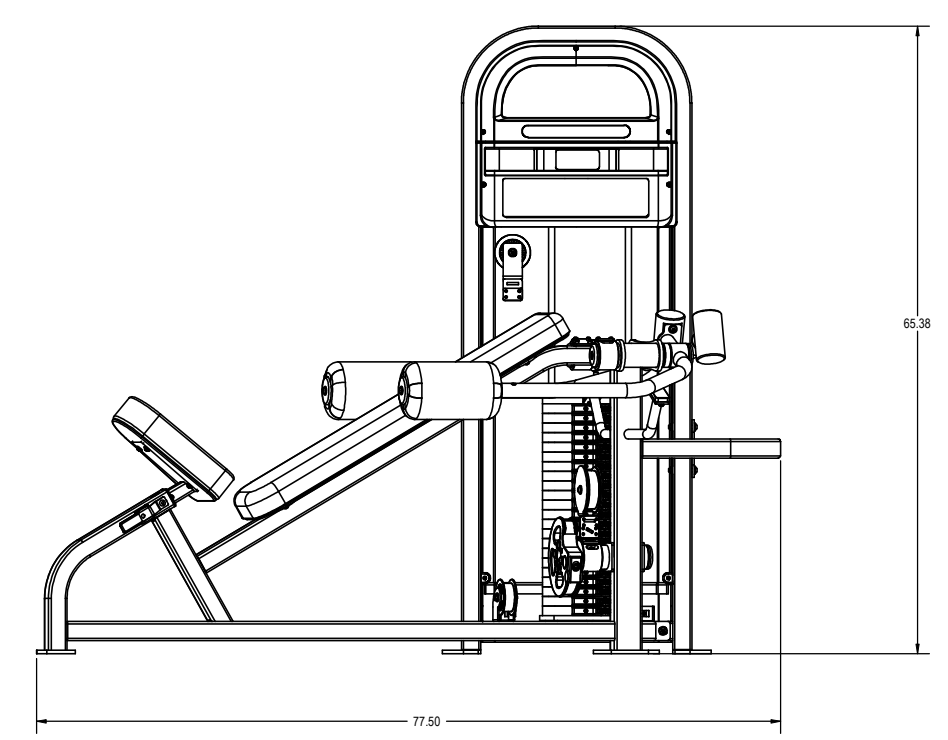
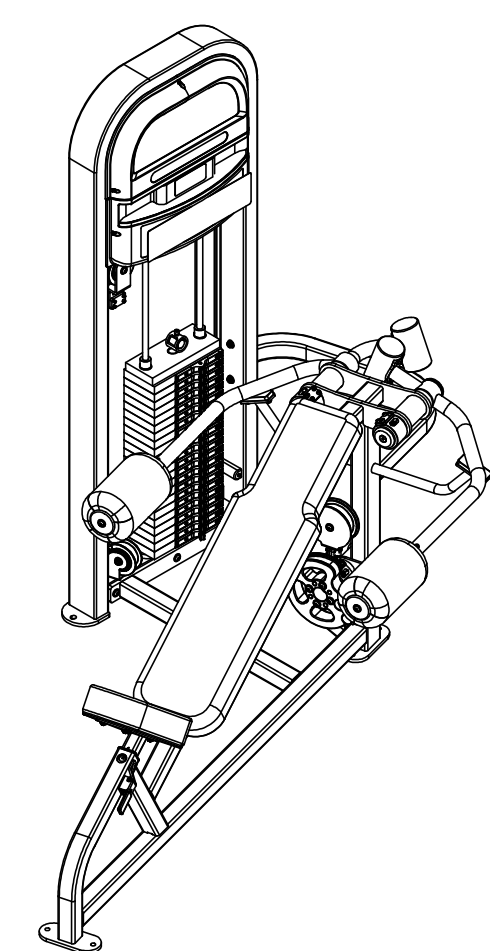
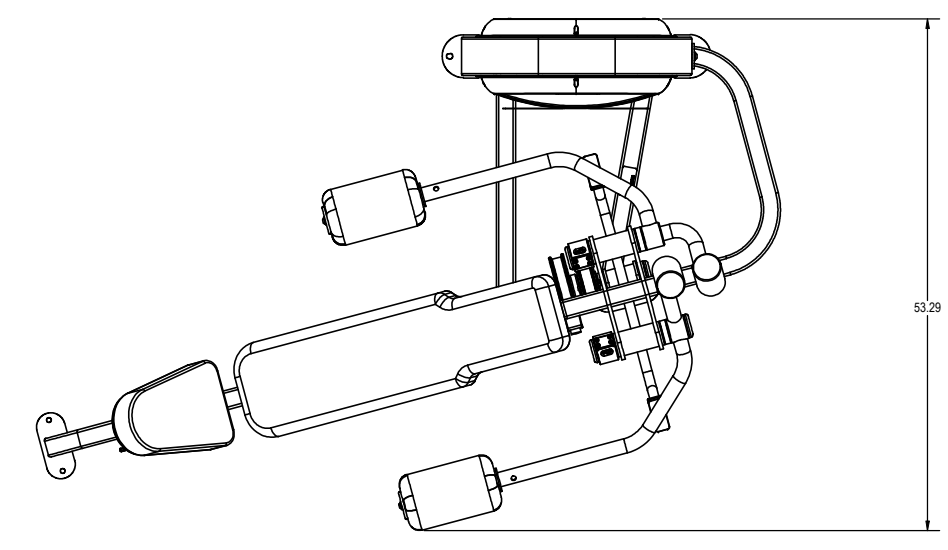

ITEM NO.	PART NUMBER	DESCRIPTION	QTY.
1	2130-0064	PLATE,KICK PLATE	1
2	3210-0364	ASSY. WELD, SEAT POST, 15DEG	1
3	3211-0149	ASSY WELD, IN LINE PULLEY CONNECT	1
4	3211-0156	ASSY WELD, MAIN FRAME, 30 DEG PEC FLY	1
5	3211-0157	30 DEG PEC FLY ARM 2	1
6	3211-0158	30 DEG PEC FLY ARM 1	1
7	3211-0171	S2303 WEIGHT FRAME	1
8	4900-PNTX	POWDER COAT TBD	2.00
10	3500-0021	ASSY,UP.,ROLLER PAD,5.70DX10LG	2
11	3500-0025	ASSY,UPHOLSTRY,13.7/8 X 8.7/8,FC-202-C	1
12	3500-0069	ASSY, UPHOLSTRY, 10x34, FS-403-A	1
13	4900-UPHX	UPHOLSTRY TBD	1.75
14	2120-0112	CAM, BELT, 3", BLT-CAM.001	3
15	2120-0154	PLATE, BELT CLAMP, 1/4, BC-002	4
16	2120-0502	PLATE, BELT CLAMP, 1/4, BC-003	2
17	2120-3826	CAP, BEARING 2 1/2 RND ALUM	4
18	2120-3939	BAR, MACH, 2.5" WELD SPACER	2
19	2120-4029	BAR, 3" OD C'BALANCE	2
21	2130-0069	BRACKET,MOUNT,KICK PLATE,IMPACT	2
22	2210-0001	SHROUD,UPPER,PRO	2
23	2210-0005	SHROUD,LOWER,SHORT,OUTSIDE,PRO	1
25	3211-0211	ASSY. WELD, CAM PIVOT AXLE	1
26	3211-0212	PULLEY BRACKET	1
27	3290-0001	ASSY, WELDMENT, HANDLE	1
28	4161-0074	SCREW, #8-18x1-1/2,PHT-AB,PH,CS	14
29	4210-0030	FHSCS, 3/8-16 X .875, BRIGHT Z	4
30	4220-0004	SHCS, 1.4-20 X 3/4L	24
31	4220-0025	SHCS, 1/2-20 X 1.75 L, Z	1
32	4220-0030	SHCS, 3/8-16 X 1.25, Z	3
33	4230-0005	BHSCS, 1/4-20 X 1/2	2
34	4230-0050	BHSCS, 3/8-16 X 1, BRIGHT, Z	2
35	4230-0051	BHSCS, 3/8-16 X 2 1/2, BRIGHT, Z	1
36	4230-0057	BHSCS, 3/8 X 2 1/4, BRIGHT, Z	8
37	4230-0059	BHSCS, 3/8-16 X 4 1/4, BRIGHT, Z	3
38	4230-0060	BHSCS, 3/8-16 X 2 3/4, BRIGHT, Z	2
39	4230-0066	BHSCS, 3/8-16 X 3/4, BRIGHT, Z	4
40	4230-0069	BHSCS, 1/4-20 X 1 3/4, BRIGHT, Z	1
41	4230-0085	BHSCS, 5/16-18 X 1 1/4, BRIGHT, Z	8
42	4230-0093	BHSCS, 1/4-20 X 3/4, BRIGHT, Z	1
43	4500-0008	Nut, JAM, 1/4-20, Z	1
44	4500-0016	NUT, NYLOC, 5/16-18, NE, Z	4
45	4500-0029	NUT,NYLOC,JAM,3/8-16,Z	10
46	4500-0046	U-NUT, #8, PANEL .025-.125	14
47	4500-0048	U-NUT, 1/4-20, EDGE .531, .025-.150	2
48	4600-0007	WASHER, SAE, 5/16, Z	12
49	4600-0009	WASHER,SAE,3/8-16,Z	30
48	4600-0025	MACHINE BUSHING, 1", 18 GAGE	5
51	4600-0027	WASHER, NYLON, 2 OD, 1 1/16 ID, 3/16	2
52	4600-0001	BELT, MECTROL, SPOOL	201
53	4900-0001	STOP, RED	2
54	4900-0052	SPRING,O.D. .5L1.5,CENTURY 921	1
55	4900-0056	PIN,PULL,CAM,BELT	1
56	4900-0057	CAM,PIN,CLAMP,CABLE	1
57	4900-0058	CLAMP,CAM,BELT	1
58	4900-0077	CAM, VRC - 11	1
59	4900-0108	SLEEVE, HANDLE, RED	1
60	4900-0139	BEARING, 1 ID X 2 OD, NR16-Z	6
61	4900-0440	PULLEY,BELT,4.75D,3/8B,1.5W,MOLDED	3
62	4900-0562	PULLEY,BELT,3.75D,3/8B,1.5W,MOLDED	2
64	5220-0005	LABEL, SAFETY, SECURE TO FLOOR	1
66	5230-0008	LOGO,STAR TRAC,IMPACT,TOP SHROUD	2
67	5230-0009	LOGO,IMPACT,LOWER SHROUD	1
68	5230-0010	LABEL,NAME,ABDOMINAL	2
69	5240-0005	LABEL, INSTRUCTIONAL, 1-12 VERT STRIP	1
70	730-0200	PLASTIC, ROLLER WASHER	2
71	2210-0009	BUSHING, SEAT POST	1
73	2210-0006	SHROUD,LOWER,MINI,INSIDE,IMPACT	1
74	4900-0522	COVER, SHROUD BRACKET	2
75	5210-0125	PLAC,IMPACT,HORZ,S2303 30 DEG PEC MACHINE	1
76	5210-0147	PLAC, LOCKLOAD WEIGHT SELECTION	1
77	3311-0081	ASSY. W-STK, 10/10LB/210LBS, BLT, SHRT, LNL, G3	1

- NOTES:
1. INTERPRET DRAWING PER ASME Y14.5M-1994.
 2. REMOVE ALL BURRS AND SHARP EDGES .015/.030.
 3. IF APPLICABLE, CRITICAL DIMENSIONS LABELED.
 4. ALL HARDWARE TO BE KITTED PER 3700-0316.
 5. ALL UPHOLSTERY TO BE KITTED PER 3700-0357.
 6. EST. GRO WT. 462 LBS.
 7. BELT FROM TOP PLATE 74"
 8. BELT FROM WGT STACK TO CAM 73"
 9. BELT BETWEEN TWO ARMS 41"
 10. BELT BETWEEN HANGING PULLEY & CAM MOUNT 13"

DOCUMENT STATUS:
RELEASED

UNLESS OTHERWISE SPECIFIED DIMENSIONS ARE IN INCHES. TOLERANCES ARE:
 DECIMALS: .015
 FRACTIONS: 1/32
 ANGLES: .015°
 HOLE DIA: .010
 UNLESS OTHERWISE SPECIFIED DIMENSIONS ARE IN INCHES. TOLERANCES ARE:
 DECIMALS: .015
 FRACTIONS: 1/32
 ANGLES: .015°
 HOLE DIA: .010

THIRD ANGLE PROJECTION

MATERIAL: SEE BOM

FINISH: N/A

VENDOR: N/A

PIN: N/A

UNISEN, INC. DBA 14410 Myford Road Irvine CA 92606

STAR TRAC

9LL-S2303AXXXXX

REV: B

DRAWN: JJJ 03/29/08

CHECKED: JJJ

APPROVED: JJJ

U.O.M.: INCH

SCALE: 1:10

SHEET 1 OF 2

SHEET SIZE: D

