

REVISIONS				
REV.	DATE	DESCRIPTION	ECO	APPROVED
A	03/21/2008	RELEASE FOR PRODUCTION	100149	DMS

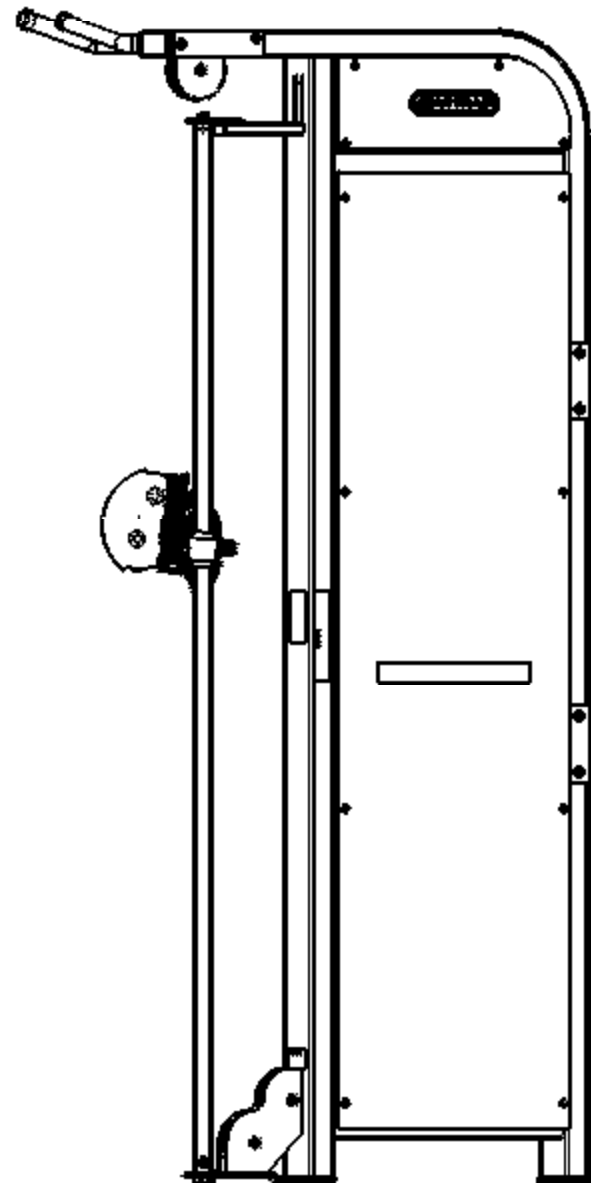
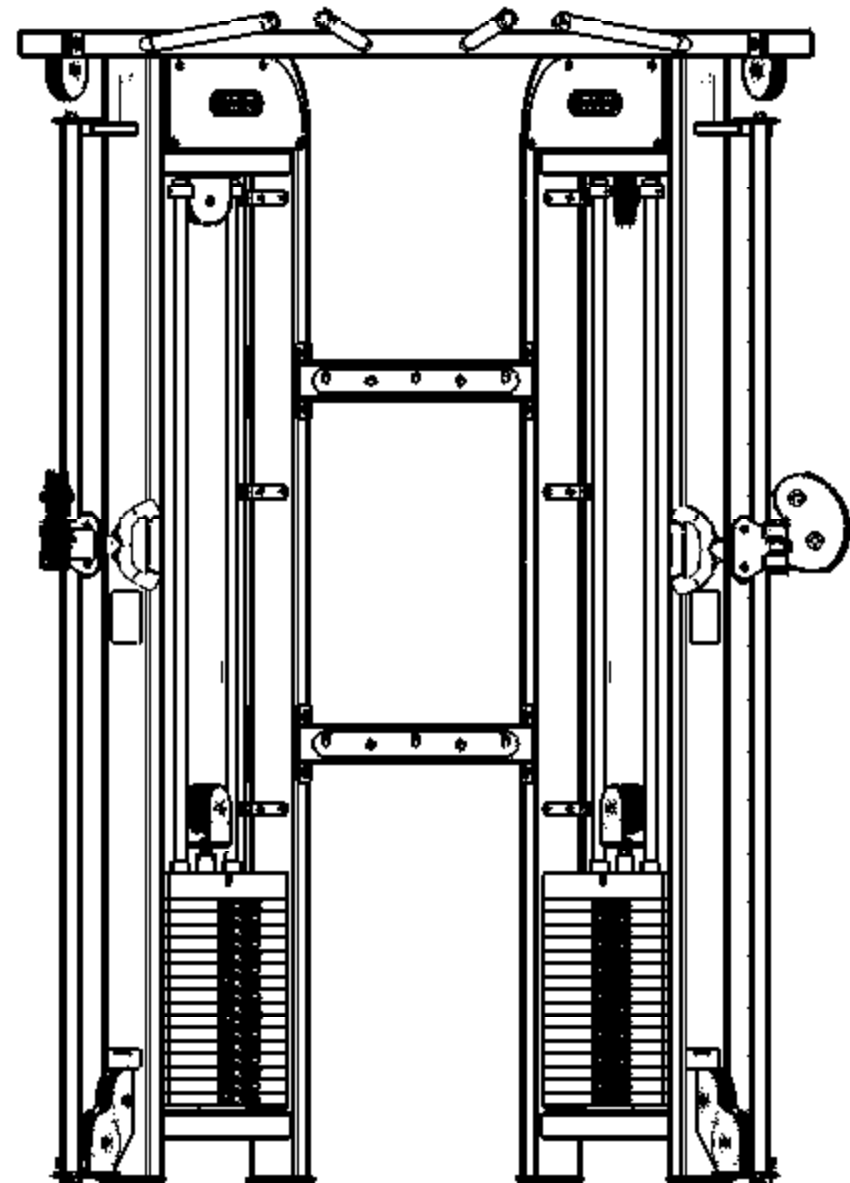
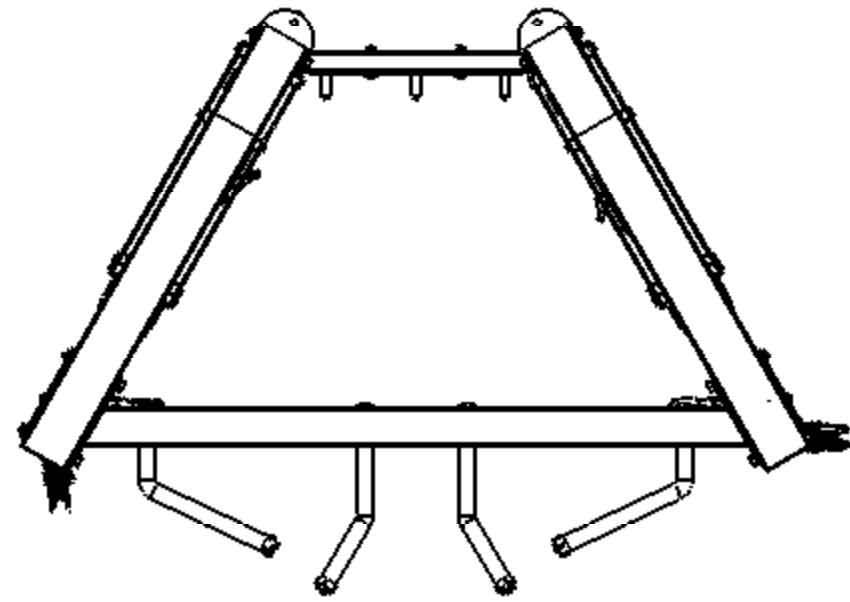

ITEM NO.	PART NUMBER	DESCRIPTION	QTY.
1	3210-0316	ASSY WELD, WGT FRAME	2
2	3210-0318	ASSY, WELD, TOP BRACE, BARS	1
3	3210-0319	ASSY, WELD, CROSS BAR	2
4	3210-0320	ASSY, WELD, EQUIP. RACK	2
5	3210-0328	ASSY, WELD, POST, ADJUST, DUAL PULLEY	2
6	3310-0080	ASSY, MECH, DUAL PULLEY, RH, DP	1
7	3310-0102	ASSY, MECH, DUAL PULLEY, LH, DP	1
8	3311-0032	ASSY, W-STK, 40LB/360, CABLE, DAP,LNL	2
9	4900-PNTX	POWDER COAT, TBD	3.0 LBS
10	3701-0001	KIT, ACC., DAP	1
11	2120-3173	BAR, MACH, 1/4X2X6, MOUNT	4
12	2120-3174	BAR, MACH, 1/4X2X7, MOUNT	2
13	2120-3331	SPACER, SHROUD, DAP	16
14	2130-0047	BRKT, MOUNT, SHROUD, 1/8"	16
15	2200-0015	SHROUD, SIDE, 3/16"	2
16	2200-0016	SHROUD, TOP, 3/16",LH	2
17	2200-0023	SHROUD, TOP, 3/16",RH	2
18	2900-0006	TUBE, GRIP, 1", BLK X 14"	2
19	2900-0016	TUBE,GRIP, 1", BLK X 12"	2
20	4161-0065	HCS 1/2-13 X 1.25 YZ8	2
21	4220-0044	SHCS, 3/8-16 x 5, BLK, Z	12
22	4220-0016	SHCS, 3/8-16 X 2.00, BZ	2
23	4230-0029	BHSCS, 3/8-16 X 2.25, BLK, Z	4
24	4230-0033	BHSCS, 3/8-16 X 1.75, BLK, Z	14
25	4230-0034	BHSCS, 1/4-20 X 1.25, BLK, Z	16
26	4230-0038	BHSCS, 1/4-20 X .625, BLK, Z	16
27	4250-0001	SSS, 10-32 X 1/8, BLK	8
28	4500-0043	NUT, ACORN 1/4-20, BLK, Z	16
29	4500-0048	U-NUT,1/4-20,EDGE .531,.025-.150	16
30	4500-0050	NUT, NYLOC, 3/8-16, BLK, Z	32
31	4600-0036	WASHER, SAE, 3/8, BLK, Z	46
32	4600-0037	WASHER, SAE, 1/4, BLK, Z	48
33	4800-0060	CABLE,1/8 X 1/4,433.625,FCAB-433.625	1
34	4900-0005	CAP, HANDLE, 1",CHROME	4
35	4900-0047	PULLEY, CABLE, 3.5D X 3/8B X 1.0 W	2
36	4900-0049	PULLEY, CABLE, 4.0D x 3/8B x 1.0W	12
37	4900-0085	PLASTIC CAP	2
38	4900-0417	CAP, BLACK, 2 X 4	2
39	4900-0448	RIVET,3/16,.126-.250 GRIP,BLK,ALUM	32
40	5220-0005	LABEL, SAFETY, SECURE TO FLOOR	2
41	5220-0025	LABEL,SAFETY,MAIN WARNING,IMPACT,WHITE	2
42	5220-0026	LABEL,WARNING,AUTHORIZED	2
43	5220-0027	LABEL,WARNING,NOT A STEP	2
44	5230-0009	LOGO,IMPACT,LOWER SHROUD	2
45	5230-0036	LOGO,STAR TRAC,8"	4
46	5220-0009	LABEL, SAFETY, GENERAL WARNING	2

NOTES:  
 1. INTERPRET DRAWING PER ASME Y14.5M-1994.  
 2. REMOVE ALL BURRS AND SHARP EDGES. 015/.030.  
 3. IF APPLICABLE, CRITICAL DIMENSIONS LABELED.

DOCUMENT STATUS:  
 RELEASED

NOTICE OF PROPRIETARY INFORMATION  
 THIS DOCUMENT SHALL NOT BE REPRODUCED NOR SHALL THE INFORMATION CONTAINED HEREIN BE USED BY OR DISCLOSED TO OTHER EXCEPT AS EXPRESSLY AUTHORIZED BY UNISEN

MATERIAL SEE BOM	TOLERANCES UNLESS OTHERWISE SPECIFIED X.XXX = ± .010 X.XX = ± .030 X.X = ± .050 X = ± .125	ANGLES = ± 2° FRACTIONS = ± 1/32	UNISEN, INC. DBA <b>STAR TRAC</b> 14410 Myford Road Irvine CA 92606	
FINISH N/A	DRAWN DMS	DATE 03/21/2008	PART NO <b>9LL-D9301-XXAAX</b>	REV <b>A</b>
	CHECKED		TITLE DAP, LL-D9301	
	APPROVED		SCALE: 1:15   SHEET 1 OF 2   SHEET SIZE: C	
	U.O.M.	INCH		

