

REVISION HISTORY				
REV	DATE	DESCRIPTION	ECO	BY
A	12/1/2011	RELEASED FOR PRODUCTION AT LAND AMERICA	----	LA
B	6/20/2012	UPDATE DESIGN OF THE LA-S5302-XXXXS.	13690	CLK

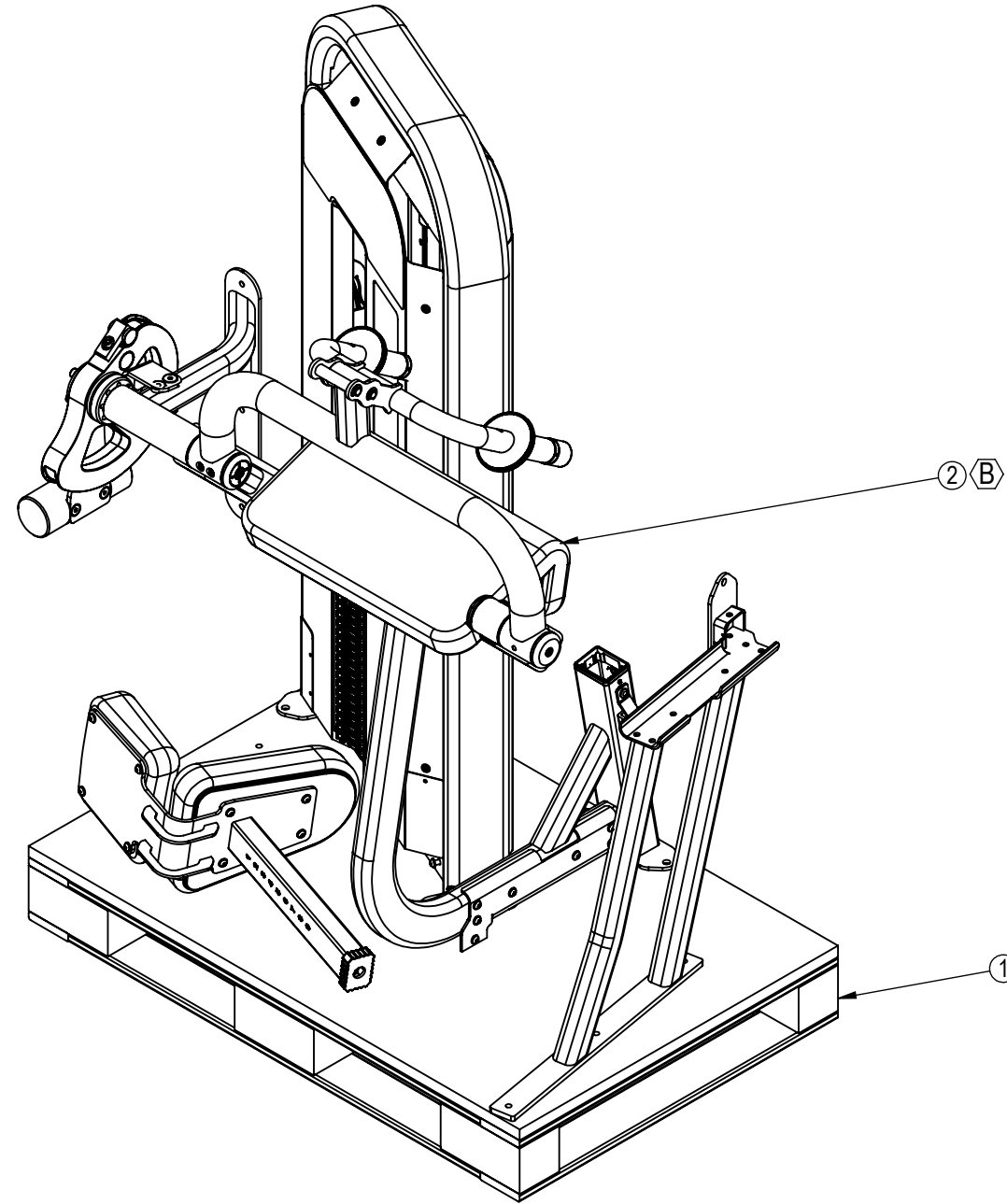

NOTICE OF PROPRIETARY INFORMATION
 THIS DOCUMENT SHALL NOT BE REPRODUCED NOR SHALL THE INFORMATION CONTAINED HEREIN BE USED BY OR DISCLOSED TO OTHER EXCEPT AS EXPRESSLY AUTHORIZED BY CORE INDUSTRIES, INC., D.B.A. STAR TRAC.

DOCUMENT STATUS:

ITEM NO.	PART NUMBER	DESCRIPTION	QTY.
1	731-0178	PALLET, 765 x 1180 x 152	1
2	LA-S5302-XXXXS	LA, SSS, TRICEPS EXTENSION	1

NOTES:

CLASS OF WORK	UNLESS OTHERWISE SPECIFIED DIMS ARE IN mm. TOLERANCES FOR MEASURE OF LENGTH ARE:							ANGLES = ±2°
	0.5 to 3	> 3 to 6	> 6 to 30	> 30 to 120	> 120 to 400	> 400 to 1000	> 1000 to 2000	
FINE	±0.05	±0.05	±0.1	±0.15	±0.2	±0.3	±0.5	----
MEDIUM	±0.1	±0.1	±0.2	±0.3	±0.5	±0.8	±1.2	±2
COARSE	±0.2	±0.3	±0.5	±0.8	±1.2	±2	±3	±4
VERY COARSE	----	±0.5	±1	±1.5	±2.5	±4	±6	±8

MATERIAL SEE BOM

FINISH N/A

VENDOR: N/A

P/N: N/A

THIRD ANGLE PROJECTION



	INITIAL	DATE
DRAWN	CLK	5/25/2012
CHECKED		
APPROVED		

CORE INDUSTRIES, INC. DBA
STAR TRAC
 14410 Myford Road
 Irvine CA 92606

STARTRAC PART NO	REV
9LA-S5302-XXXXS	B
TITLE LA, SSS, TRICEPS EXTENSION	
SCALE: 1:12	SHEET 1 OF 1 SHEET SIZE: B