

REVISION HISTORY				
REV	DATE	DESCRIPTION	ECO	BY
A	12/1/2011	RELEASED FOR PRODUCTION AT LAND AMERICA	----	LA
B	5/30/2012	MAKE DRAWING	13688	CLK

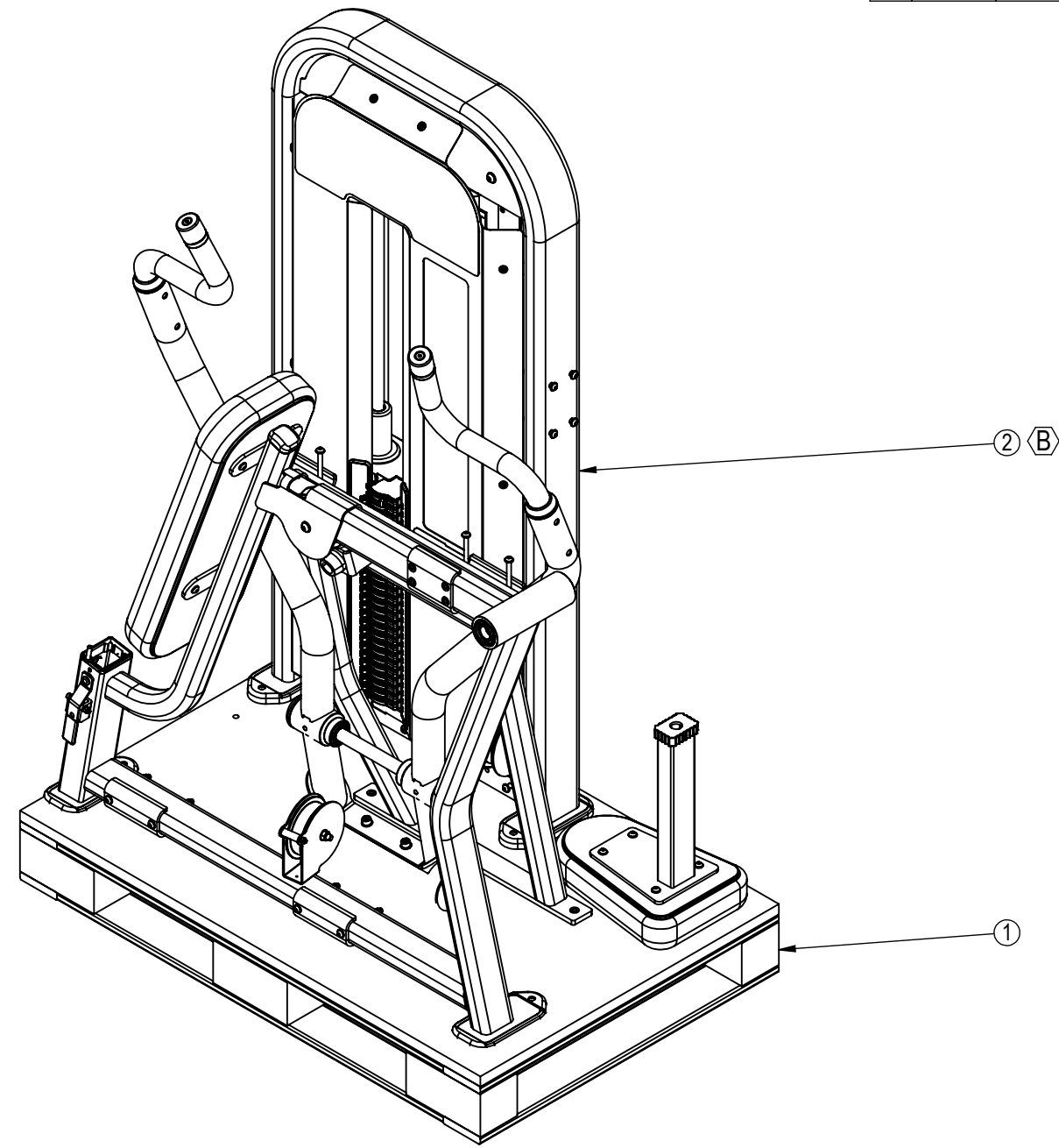

NOTICE OF PROPRIETARY INFORMATION  
 THIS DOCUMENT SHALL NOT BE REPRODUCED NOR SHALL THE INFORMATION CONTAINED HEREIN BE USED BY OR DISCLOSED TO OTHER EXCEPT AS EXPRESSLY AUTHORIZED BY CORE INDUSTRIES, INC., D.B.A. STAR TRAC.

**DOCUMENT STATUS:**

ITEM NO.	PART NUMBER	DESCRIPTION	QTY.
1	731-0178	PALLET, 765 x 1180 x 152	1
2	LA-S4307-XXXXS	LA, SSS, SHOULDER PRESS	1

NOTES:

CLASS OF WORK	UNLESS OTHERWISE SPECIFIED DIMS ARE IN mm. TOLERANCES FOR MEASURE OF LENGTH ARE:							ANGLES = ±2°
	0.5 to 3	>3 to 6	>6 to 30	>30 to 120	>120 to 400	>400 to 1000	>1000 to 2000	
FINE	±0.05	±0.05	±0.1	±0.15	±0.2	±0.3	±0.5	----
MEDIUM X	±0.1	±0.1	±0.2	±0.3	±0.5	±0.8	±1.2	±2
COARSE	±0.2	±0.3	±0.5	±0.8	±1.2	±2	±3	±4
VERY COARSE	----	±0.5	±1	±1.5	±2.5	±4	±6	±8

MATERIAL  
SEE BOM

FINISH  
N/A

VENDOR: N/A

P/N: N/A

THIRD ANGLE PROJECTION



	INITIAL	DATE
DRAWN	CLK	5/22/2012
CHECKED		
APPROVED		

CORE INDUSTRIES, INC. DBA  
 14410 Myford Road  
 Irvine CA 92606

STARTRAC PART NO.	REV
<b>9LA-S4307-XXXXS</b>	<b>B</b>
TITLE <b>SHOULDER PRESS ON PALLET</b>	
SCALE: 1:12	SHEET 1 OF 1   SHEET SIZE: B

Grid labels: 9, 8, 7, 6, 5, 4, 3, 2, 1 (columns); J, I, H, G, F, E, D, C, B, A (rows)