

REVISION HISTORY				
REV	DATE	DESCRIPTION	ECO	BY
A	12/1/2011	RELEASED FOR PRODUCTION AT LAND AMERICA	----	LA
B	5/23/2012	MAKE DRAWING	13685	CLK

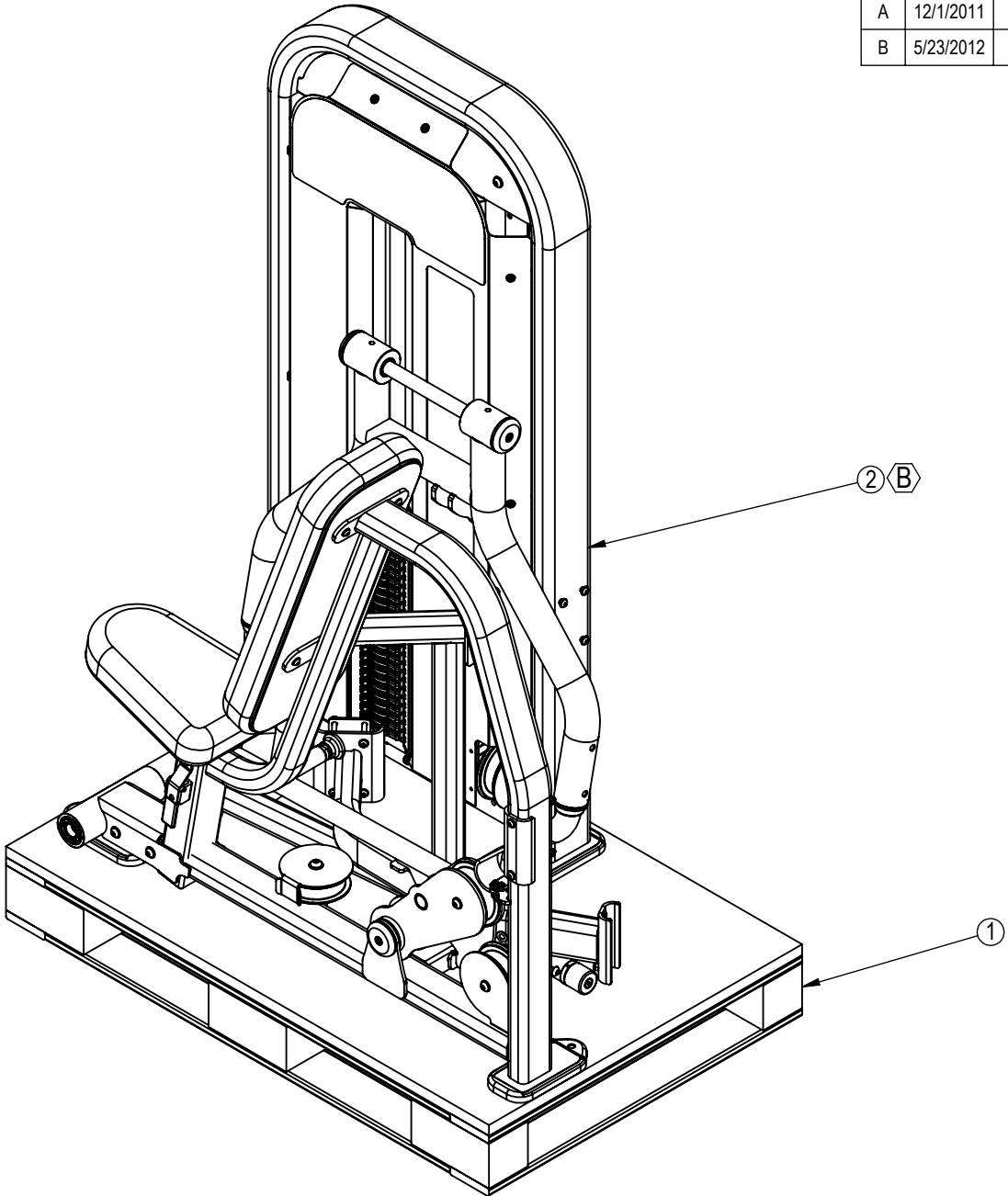

NOTICE OF PROPRIETARY INFORMATION  
 THIS DOCUMENT SHALL NOT BE REPRODUCED NOR SHALL THE INFORMATION CONTAINED HEREIN BE USED BY OR DISCLOSED TO OTHER EXCEPT AS EXPRESSLY AUTHORIZED BY CORE INDUSTRIES, INC., D.B.A. STAR TRAC.

**DOCUMENT STATUS:**

ITEM NO.	PART NUMBER	DESCRIPTION	QTY.
1	731-0178	PALLET, 765 x 1180 x 152	1
2	LA-S4301-XXXXS	VERTICAL PRESS	1

NOTES:

CLASS OF WORK	UNLESS OTHERWISE SPECIFIED DIMS ARE IN mm. TOLERANCES FOR MEASURE OF LENGTH ARE:							ANGLES = ±2°
	0.5 to 3	> 3 to 6	> 6 to 30	> 30 to 120	> 120 to 400	> 400 to 1000	> 1000 to 2000	
FINE	±0.05	±0.05	±0.1	±0.15	±0.2	±0.3	±0.5	----
MEDIUM X	±0.1	±0.1	±0.2	±0.3	±0.5	±0.8	±1.2	±2
COARSE	±0.2	±0.3	±0.5	±0.8	±1.2	±2	±3	±4
VERY COARSE	----	±0.5	±1	±1.5	±2.5	±4	±6	±8

MATERIAL SEE BOM

FINISH N/A

VENDOR: N/A

P/N: N/A

THIRD ANGLE PROJECTION



DRAWN	INITIAL CLK	DATE 5/17/2012
CHECKED		
APPROVED		

CORE INDUSTRIES, INC. DBA **STAR TRAC** 14410 Myford Road Irvine CA 92606

STARTRAC PART NO	REV
<b>9LA-S4301-XXXXS</b>	<b>B</b>
TITLE	
VERTICAL PRESS ON PALLET	
SCALE: 1:12	SHEET 1 OF 1   SHEET SIZE: B