

REVISION HISTORY				
REV	DATE	DESCRIPTION	ECO	BY
A	12/1/2011	RELEASE FOR PRODUCTION AT LAND AMERICA	----	LA
B	4/25/2012	UPDATE COMPONENTS WITHIN THE MACHINE.	13672	CLK

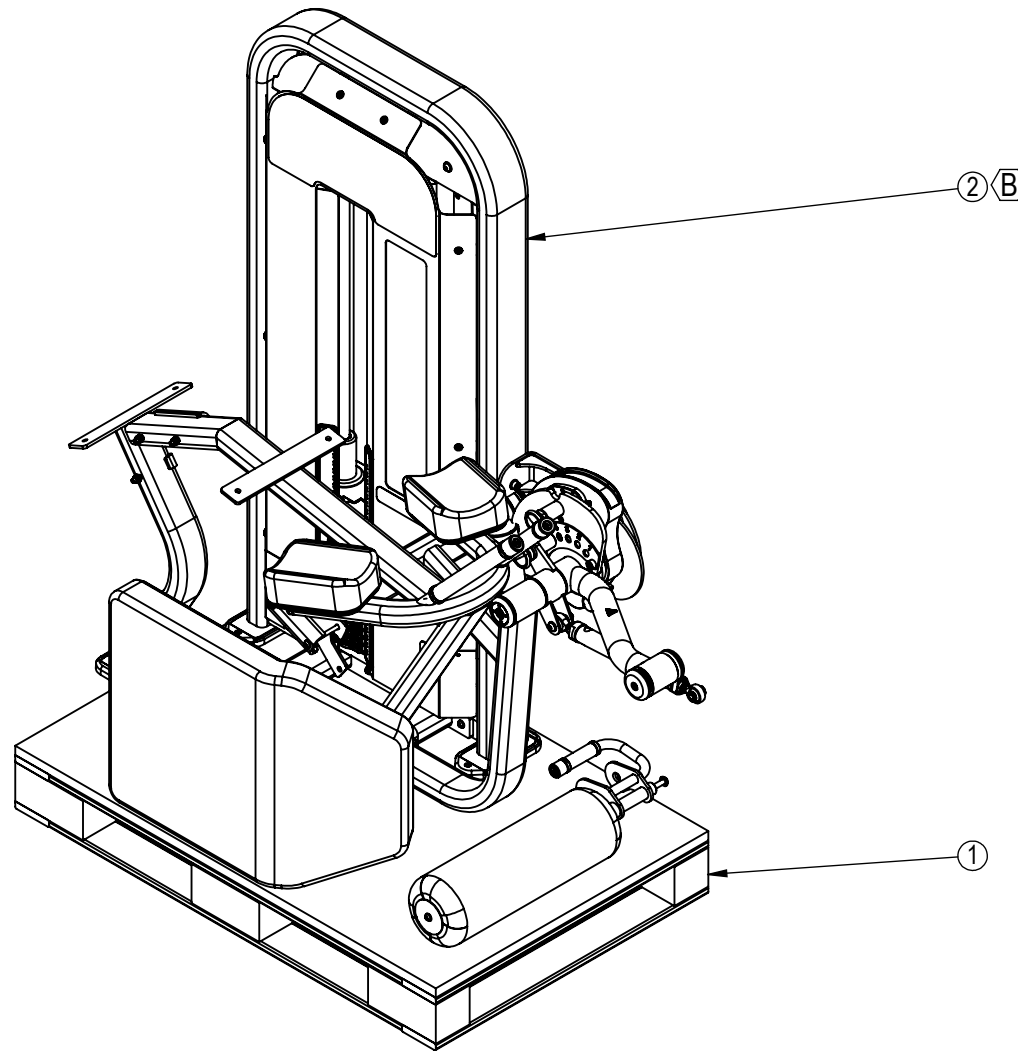

NOTICE OF PROPRIETARY INFORMATION
 THIS DOCUMENT SHALL NOT BE REPRODUCED NOR SHALL THE INFORMATION CONTAINED HEREIN BE USED BY OR DISCLOSED TO OTHER EXCEPT AS EXPRESSLY AUTHORIZED BY CORE INDUSTRIES, INC., D.B.A. STAR TRAC.

DOCUMENT STATUS:

ITEM NO.	PART NUMBER	DESCRIPTION	QTY.
1	731-0178	PALLET, 765 x 1180 x 152	1
2	LA-S1301-XXXXS	LA, SSS, LEG CURL	1

NOTES:

CLASS OF WORK	UNLESS OTHERWISE SPECIFIED DIMS ARE IN mm. TOLERANCES FOR MEASURE OF LENGTH ARE:							ANGLES = ±2°
	0.5 to 3	> 3 to 6	> 6 to 30	> 30 to 120	> 120 to 400	> 400 to 1000	> 1000 to 2000	
FINE	±0.05	±0.05	±0.1	±0.15	±0.2	±0.3	±0.5	----
MEDIUM	±0.1	±0.1	±0.2	±0.3	±0.5	±0.8	±1.2	±2
COARSE	±0.2	±0.3	±0.5	±0.8	±1.2	±2	±3	±4
VERY COARSE	----	±0.5	±1	±1.5	±2.5	±4	±6	±8

MATERIAL
SEE BOM

FINISH
N/A

VENDOR: N/A

P/N: N/A

THIRD ANGLE PROJECTION



DRAWN	INITIAL CLK	DATE 4/19/2012
CHECKED		
APPROVED		

CORE INDUSTRIES, INC. DBA
 14410 Myford Road
 Irvine CA 92606

STARTRAC PART NO	REV
9LA-S1301-XXXXS	B
TITLE LA, SSS, LEG CURL	
SCALE: 1:15	SHEET 1 OF 1 SHEET SIZE: B

Grid coordinates: 9, 8, 7, 6, 5, 4, 3, 2, 1 (horizontal); J, I, H, G, F, E, D, C, B, A (vertical)