

REVISION HISTORY				
REV	DATE	DESCRIPTION	ECD	BY
A	5/19/09	PRODUCTION RELEASE		MLB

ITEM NO.	PART NUMBER	DESCRIPTION	QTY.
14	2120-0292	Guide, Bearing, 10", 10, 20	2

ITEM NO.	PART NUMBER	DESCRIPTION	QTY.
15	2120-0275	STANDOFF, Z, ALUMINUM	6
16	2120-3347	CLAMP,BELT BARREL,1X1,30,KNURLED	1

ITEM NO.	PART NUMBER	DESCRIPTION	QTY.
17	2120-3866	SPACER, PULLEY COVERS	1
18	2120-3909	SHAFT, KNEE PIVOT, CHIN DIP	1
19	2120-4013	STOP, 1.0 SHAFT	2
20	2120-4014	CAP, BEARING TUBE STOP	2
21	2140-0073	SHEET, BENT, 16 GA X 50, GUARD	2
22	2211-0136	ASSY, WELD, ROM, KNEE PIVOT	1
23	4210-0029	PHCS, 3/8-16 X 1.00	10
24	4230-0043	SHCS, 5/16-18X1 1/2, BLK	1
25	4230-0053	BHSCS, 3/8-16 X 4, BRIGHT, Z	4
26	4230-0056	BHSCS, 3/8 X 3, BRIGHT, Z	2
27	4230-0057	BHSCS, 3/8 X 2 1/4, BRIGHT, Z	2
28	4230-0059	BHSCS, 3/8-16 X 4 1/4, BRIGHT, Z	1
29	4230-0060	BHSCS, 3/8-16 X 2 3/4, BRIGHT, Z	1
30	4230-0065	BHSCS, 3/8-16 X 1/2, BRIGHT, Z	2
31	4230-0066	BHSCS, 3/8-16 X 3/4, BRIGHT, Z	4
32	4230-0071	BHSCS, 1/2-13 X 3, BRIGHT, Z	4
33	4230-0075	BHSCS, 1/2-13 X 1, BRIGHT, Z	2
34	4230-0080	BHSCS, 5/16-18 X 2 3/4, BRIGHT, Z	4
35	4250-0001	SSS, 10-32 X 1/8, BLK	8
36	4500-0002	NUT, NYLOC, 5/16-18	1
37	4500-0029	NUT, NYLOC, JAM, 3/8-16, Z	18
38	4500-0044	NUT, WELD, 5/16-18, 5/8, BASE	1
39	4500-0071	NUT, NYLOC, 1/2-13	4
40	4600-0005	WASHER, USS, 1/2, Z	2
41	4600-0007	WASHER, SAE, 5/16, Z	5
42	4600-0008	WASHER, SAE, 1/2, Z	8
43	4600-0009	WASHER, SAE, 3/8-16, Z	40
44	4600-0025	MACHINE BUSHING, 1", 18 GAUGE	4
45	4800-0001	BELT, MECTROL, SPOOL	99 IN
46	4900-0005	CAP, HANDLE, 1" CHROME	4
47	4900-0037	BEARING, FLANGE, 1.00 X 1.00H	2
48	4900-0118	BEARING, ROLLER, 1", 1 1/4 OPEN	4
49	4900-0129	LINEAR SHFT, 1" X 40	2
50	4900-0136	CAP, WEIGHT, NO INDICATOR, BLK	2
51	4900-0139	BEARING, 1 ID X 2 OD, NR16-Z	4
52	4900-0157	STOP, 1R X 1 X 3/8, F-DAS	4
53	4900-0183	SHOCK, 30 lbs, 9.00 X 5.505	1
54	4900-0480	PULLEY BELT, 4.750, 3/8", 1.5W, MOLDED	2
55	4900-0540	BALL, STD, 10 mm X 25 LC, THD	2
56	4900-0576	PULL PIN, 1/2", K-20DR	1
57	5210-0143	PLAC, IMPACT HORIZ, S6302, CHINDIP ASSIST	1
58	5220-0002	LABEL, SAFETY, KEEP HANDS SMALL	1
59	5220-0005	LABEL, SAFETY, SECURE TO FLOOR	1
60	5290-0001	SERIAL NUMBER	1
61	5220-0050	SCREW, SHCS, 3/8-24 X 25, Z	6
62	4900-0574	Rivet Nut, 3/8-16	2
63	4900-0588	CAP, 2.0 x 2.0, BLACK, TEXTURED	8
64	4230-0050	BHSCS, 3/8-16 X 1, BRIGHT, Z	2
65	4900-0629	SPRNG, 1/8 X 3/4	4
66	2143-0137	PLATE, FOOT PAD, MED, 11" W/HOLES	4
67	2400-0050	PAD, FOOT, RUBBER, MED	4
68	3311-0300	ASSY, MECH WT FRAME, S6302 PR	1

ITEM NO.	PART NUMBER	DESCRIPTION	QTY.
1	3211-0129	ASSY, WELD, MAIN FRAME, CHIN DIP	1
2	3211-0130	ASSY, WELD, CHIN GRP, LH	1
3	3211-0131	ASSY, WELD, CHIN GRP, RH	1
4	3211-0132	ASSY, WELD, ADJUSTABLE GRP	2
5	3211-0133	ASSY, WELD, KNEE SLED, CHIN DIP	1
6	3211-0134	ASSY, WELD, KNEE PIVOT, CHIN DIP	1
7	3211-0250	ASSY, WELD, W STK CONN	1
8	2161-0025	PULLEY COVER, OUTER	1
9	2161-0026	PULLEY COVER, INNER	1
10	4900-PNTX	POWDER COAT, TBD	2.0 LBS.
11	3500-0057	ASSY, UPHOLSTRY, 15 X 12, F 42Z-C	1
12	4900-UPHX	UPHOLSTRY, TBD	30 LIN. YDS.
13	1400-0001	TUBE, ROUND, 1", RUBBER, BLK	41 IN.

- NOTES:
- INTERPRET DRAWING PER ASME Y14.5M-1994
 - IF APPLICABLE, CRITICAL DIMENSIONS LABELED.
 - ALL HARDWARE IS KITTED PER 3700-0533.
 - ALL UPHOLSTERY IS KITTED PER 3700-0253
- EST. GROSS WT. 856 LBS.
KNEE PAD ASSY SETUP HEIGHT.

DOCUMENT STATUS:
ECO

MATERIAL
SEE BOM

FINISH
N/A

VENOR: N/A

UNISEN INC. DBA 14410 Myford Road
Irvine CA 92606

9PR-S6302CXXXXX X01
CHIN DIP ASSIST, PR

SCALE: 1:12 SHEET 2 OF 2 SHEET SIZE: B

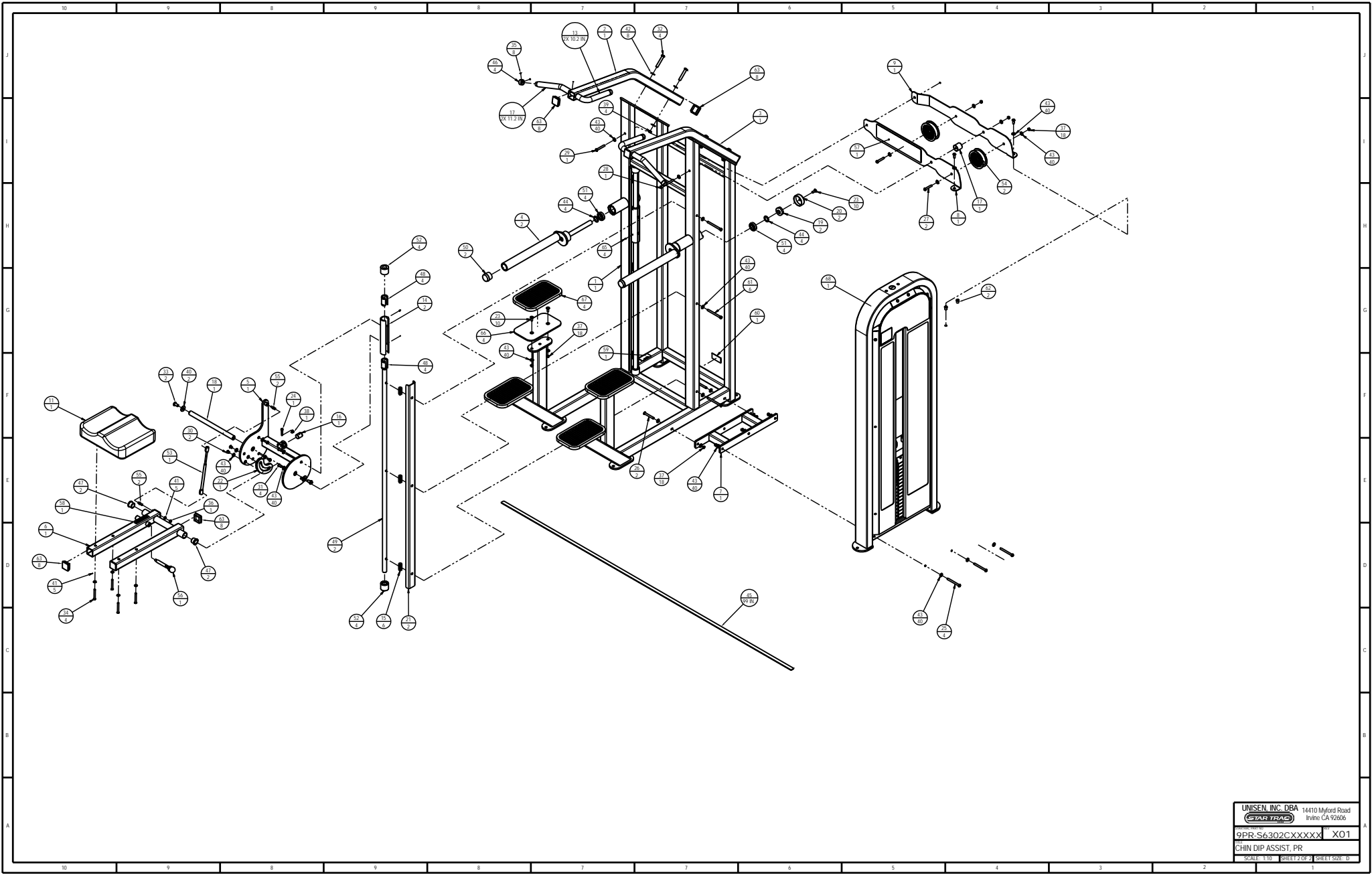

UNISEN, INC. DBA 14410 Myford Road
 STARTRAC Irvine, CA 92606
 9PR-S6302CXXXXX X01
 CHIN DIP ASSIST, PR
 SCALE: 1:10 SHEET Z0P2 SHEET SIZE: D