

REVISIONS				
REV.	DATE	DESCRIPTION	ECO	APPROVED
A	5/8/2007	PRODUCTION RELEASE	100029	SLS
B	8/1/2007	4900-0151 WAS 4900-0003	100036	SLS
C	12/28/2007	MODIFIED CONNECTOR ARM AND OTHER WELDMENTS RE-DESIGNED	100077	CSM

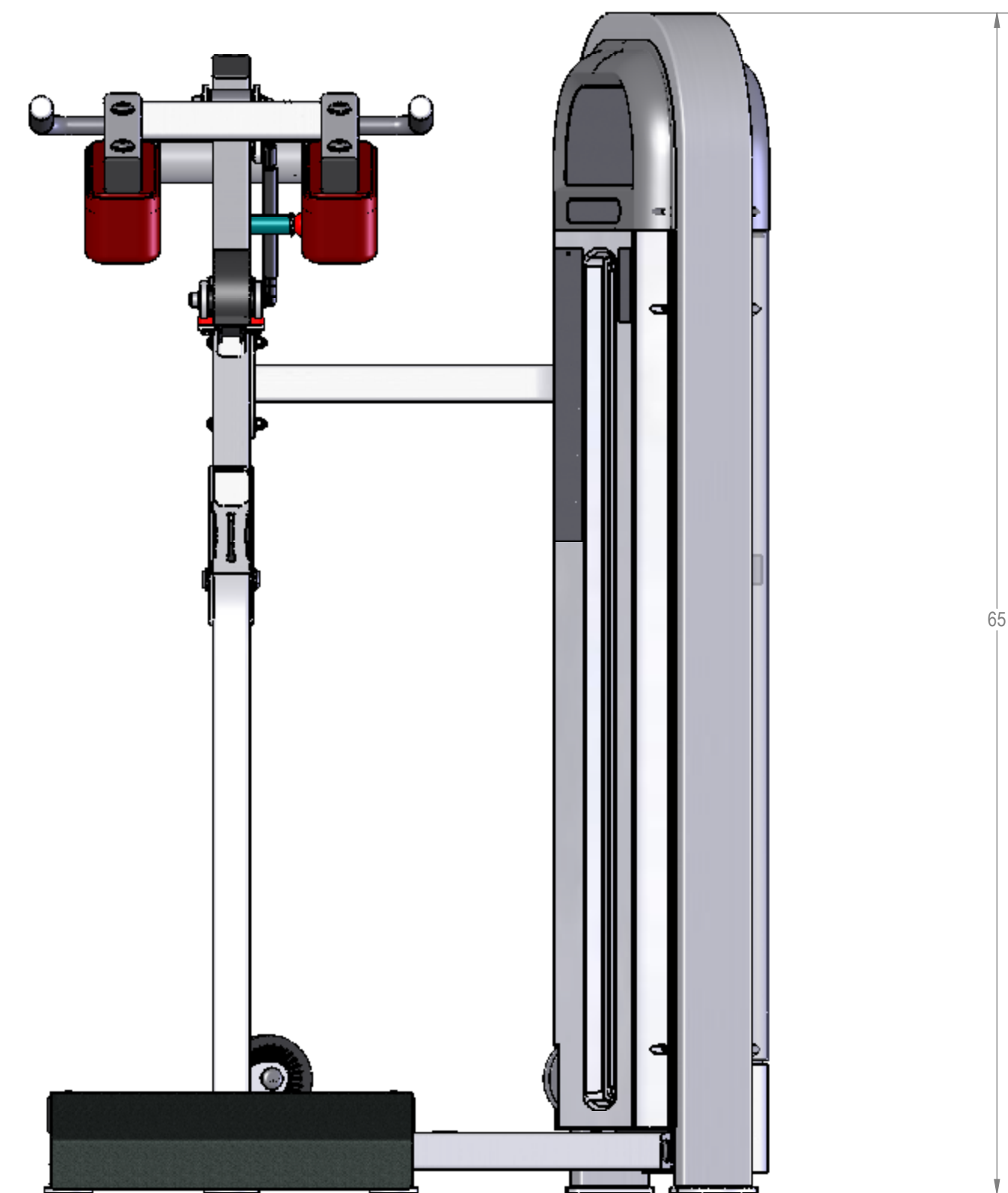
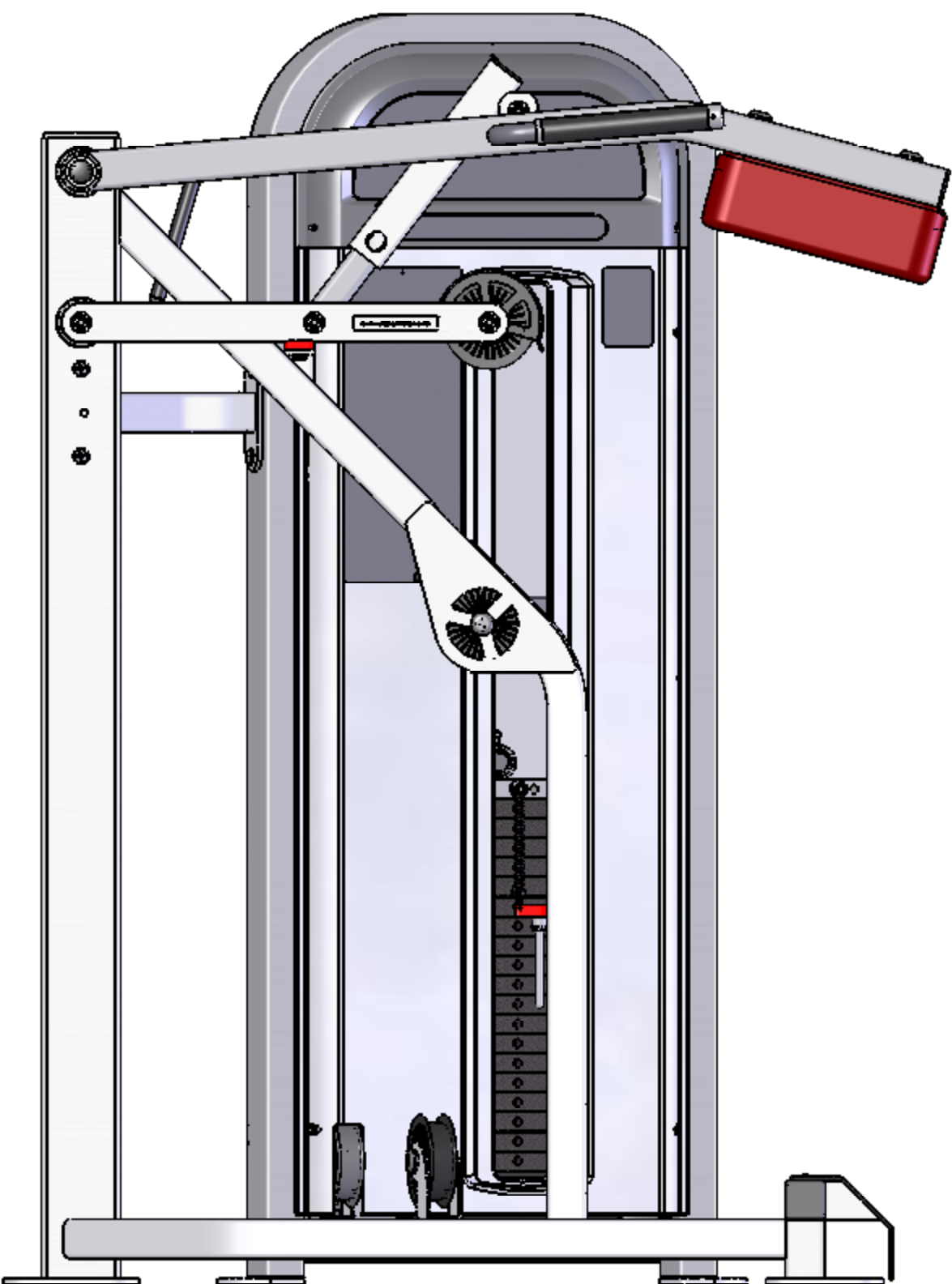
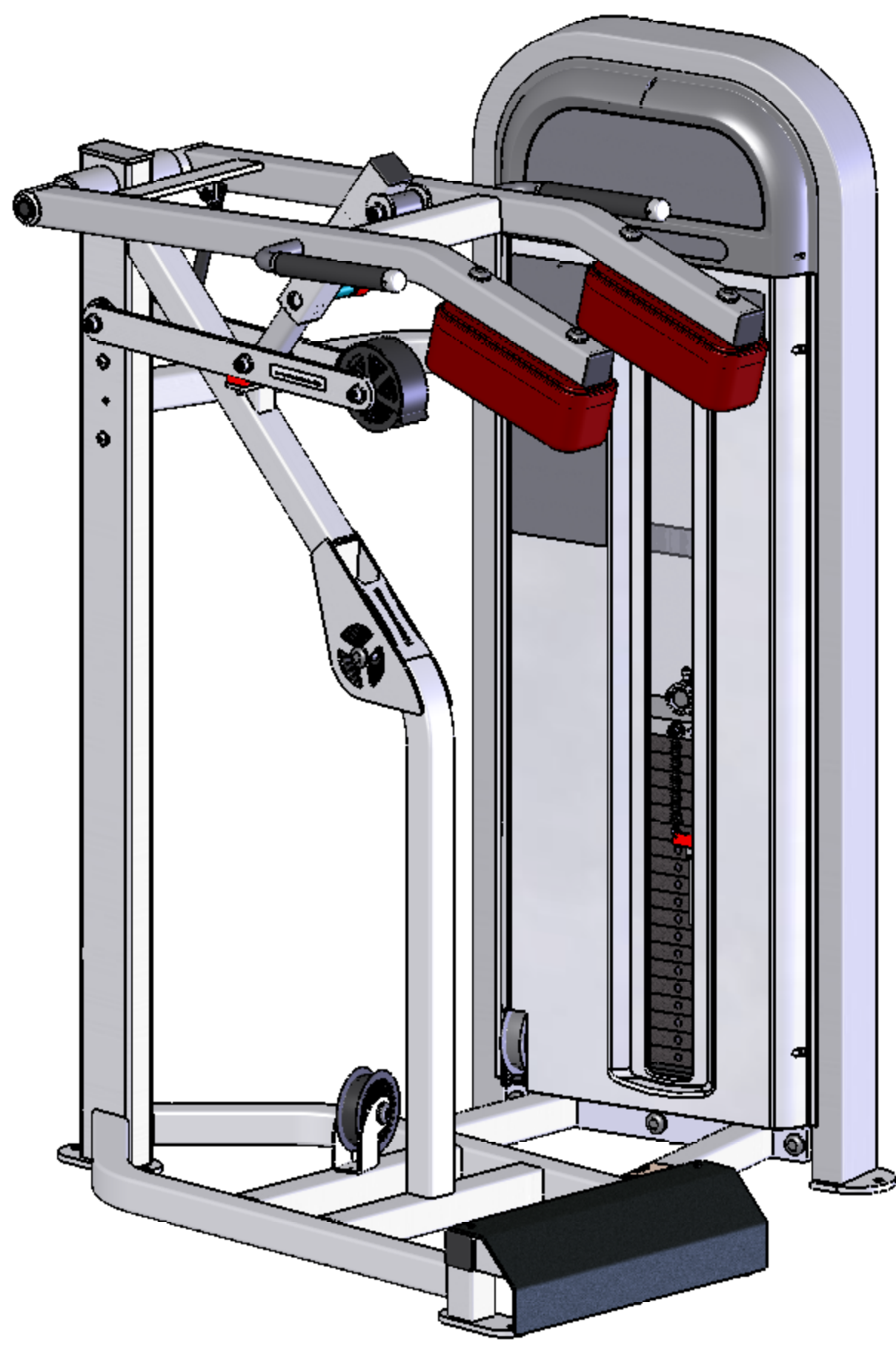
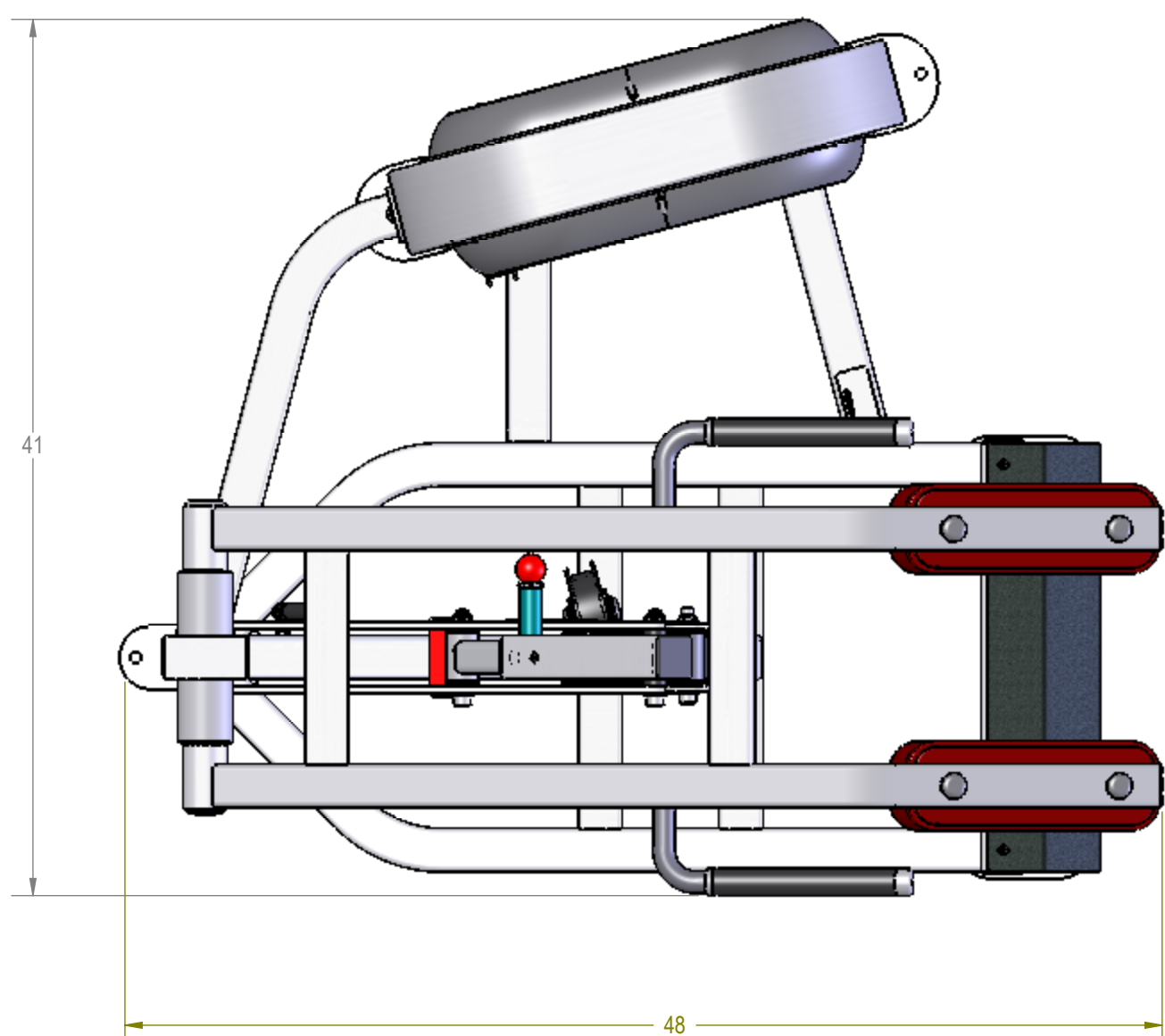

ITEM NO.	PART NUMBER	DESCRIPTION	QTY.
1	3211-0075	ASSY, WELD, MAIN FRAME, PR-S1309	1
2	3211-0076	ASSY, WELD, WT STACK, COMPL, PR-S1309	1
3	3211-0092	ASSY, WELD, LINKAGE TUBE, S1309	1
4	3211-0094	ASSY, WELD, ARMS, S1309	1
5	2130-0064	PLATE, KICK PLATE	1
6	3211-0186	ASSY, WELD, CONNECTOR ARM, S1309	1
7	2164-0050	BAR, MACH, 3/8 X 2.23, 4 HOLE	1
8	2164-0053	BAR, MACH, 3/8 X 2.23, 3 HOLE	1
9	3310-0120	ASSY, W-STK, 15LB/300LBS, BELT, SHRT	1
10	3500-0055	ASSY, UPHOLSTRY, 12x4, FL-108-B	2
11	4900-0440	PULLEY, BELT, 4.75D, 3/8B, 1.5W, MOLDED	4
12	1400-0001	TUBE, GRIP, 1", BLK X 8 9/16"	2
13	2120-0154	PLATE, BELT CLAMP, 1/4, BC-002	1
14	2120-0502	PLATE, BELT CLAMP, 1/4, BC-003	1
15	2120-0769	RACE, INNER, 1 X 2 5/8L	3
16	2120-0598	TUBE, SQR, SEATPOST, PLASTIC	1
17	2120-3739	BAR, MACH, 1 RD. X 1 1/2, S1309	1
18	2130-0069	BRACKET, MOUNT, KICK PLATE, IMPACT	2
19	2140-0324	PLATE, FOOT, 3/16 THK., S1309	1
20	2210-0001	SHROUD, UPPER, PRO	2
21	2120-3572	SHRD, MOD, STANDING CALF RAISE, PR-S1309	1
22	2210-0005	SHROUD, LOWER, SHORT, OUTSIDE, PRO	1
23	3211-0093	ASSY, WELD, LINKAGE, S1309	1
24	3211-0102	ASSY, WELD, PULLEY COVER, S1309	1
25	4161-0009	HCS, 3/12-18 X 2.75 Z	4
26	4161-0018	HFBOLT, SHOULDER, 3/8-16x2.25x1-C	1
27	4161-0019	HFBOLT, SHOULDER, 3/8-16x2.5x1-C	3
28	4161-0020	HCS, 3/8-16 x 2.75 Z5	1
29	4161-0023	HHC, 3/8-16x4.00 Z	1
30	4161-0024	HCS 3/8-16 X 4.25 Z5	2
31	4161-0074	SCREW, #8-18x1-1/2, PHT-AB, PH, CS	14
32	4220-0005	SHCS, 1/4-20 x 1.0	4
33	4220-0022	SHCS, 1/2-20 X 4.0, ZINC PL.	4
34	4230-0005	BHSCS, 1/4-20 X 1/2	2
35	4230-0006	BHSCS, 250-20 X .750 BO	3
36	4250-0001	SSS, 10-32 X 1/8, BLK	4
37	4250-0015	SSSCP, 1/4-20 X 1/2, BLK	2
38	4500-0002	NUT, NYLOC, 5/16-18	4
39	4500-0008	Nut, JAM, 1/4-20, Z	2
40	4500-0024	JAMNUT, NYLOK, 1/2-20	4
41	4500-0029	NUT, NYLOC, JAM, 3/8-16, Z	8
42	4500-0046	U-NUT, #8, PANEL 025-125	14
43	4500-0048	U-NUT, 1/4-20, EDGE .531, 025-150	2
44	4600-0006	FLAT WASHER, 1/4 Z	2
45	4600-0007	WASHER, SAE, 5/16, Z	8
46	4600-0008	WASHER, SAE, 1/2, Z	8
47	4600-0009	WASHER, SAE, 3/8-16, Z	16
48	4600-0025	MACHINE BUSHING, 1", 18 GAGE	2
49	4800-0001	BELT, MECTROL	1
50	4900-0001	STOP, RED	1
51	4900-0151	PULL PIN, 1/2", K320	1
52	4900-0005	CAP, HANDLE, 1", CHROME	2
53	4900-0037	BEARING, FLANGE, 1.00B X 1.00H	4
54	4900-0086	Cap, Black, 2 x 2	5
55	4900-0088	CAP, BLACK, 1" ROUND	2
56	4900-0139	BEARING, 1 ID X 2 OD, NR16-Z	4
57	4900-0145	CAP, BLACK, RH-20	11
58	4900-0148	WASHER, CAP, 5/16", RHW-204	4
59	4900-0149	WASHER, CAP, 3/8", RHW-205	7
60	4900-0184	SHOCK, 120 lbs, 8.40C X 3.5S	1
61	4900-0441	PULLEY, BELT, 4.75D, 1/2B, 1.5W, MOLDED	1
62	4900-0445	PULLEY, BELT, 4.75D, 3/8B, 2.0W, MOLDED	1
63	4900-0540	BALL STUD, 10 mm X .75" LG, THD	2
64	5210-0119	PLAC, IMPACT, PR-S1309, STANDING CALF MACH	1
65	5220-0002	LABEL, SAFETY, KEEP HANDS, SMALL	2
66	5220-0005	LABEL, SAFETY, SECURE TO FLOOR	1
67	5220-0023	LABEL, SAFETY, MAIN WARNING, IMPACT	1
68	5230-0008	LOGO, STAR TRAC, IMPACT, TOP SHROUD	2
69	5230-0009	LOGO, IMPACT, LOWER SHROUD	1
70	5230-0037	LABEL, NAME, STANDING CALF	2
71	5240-0005	LABEL, INSTRUCTIONAL, 1-12 VERT STRIP	1
72	4230-0056	BHSCS, 3/8 X 3, BRIGHT Z	4
73	4600-0013	WASHER, SAE, 3/8, Z	8
74	4500-0030	NUT, NYLOC, JAM, 3/8-16, THICK Z	4

- NOTES:
1. INTERPRET DRAWING PER ASME Y14.5M-1994.
 2. REMOVE ALL BURRS AND SHARP EDGES .015/.030.
 3. IF APPLICABLE, CRITICAL DIMENSIONS LABELED.

DOCUMENT STATUS:
ECO

MATERIAL
SEE BOM

FINISH
N/A

NOTICE OF PROPRIETARY INFORMATION
THIS DOCUMENT SHALL NOT BE REPRODUCED NOR SHALL THE INFORMATION CONTAINED HEREIN BE USED BY OR DISCLOSED TO OTHER EXCEPT AS EXPRESSLY AUTHORIZED BY UNISEN

TOLERANCES UNLESS OTHERWISE SPECIFIED
 XXXX = ±.010 ANGLES = ±1°
 XXX = ±.030 FRACTIONS = ±.132
 XX = ±.050
 X = ±.125

UNISEN, INC. DBA
STAR TRAC
 14410 Myford Road
 Irvine CA 92606

DRAWN: SLS DATE: 02/26/07
 CHECKED: SLS
 APPROVED: SLS

PART NO: **9PR-S1309-XXXX** REV: **B01**
 TITLE: PR-S1309, (FL-109), STANDING CALF MACHINE
 SCALE: 1:8 | SHEET 1 OF 2 | SHEET SIZE: D

