

REVISION HISTORY				
REV	DATE	DESCRIPTION	ECO	BY
A	11/29/2011	PRODUCTION RELEASE	13612	SCN
B	5/17/2013	REMOVED 740-2001, ADDED 740-4011	14149	KY

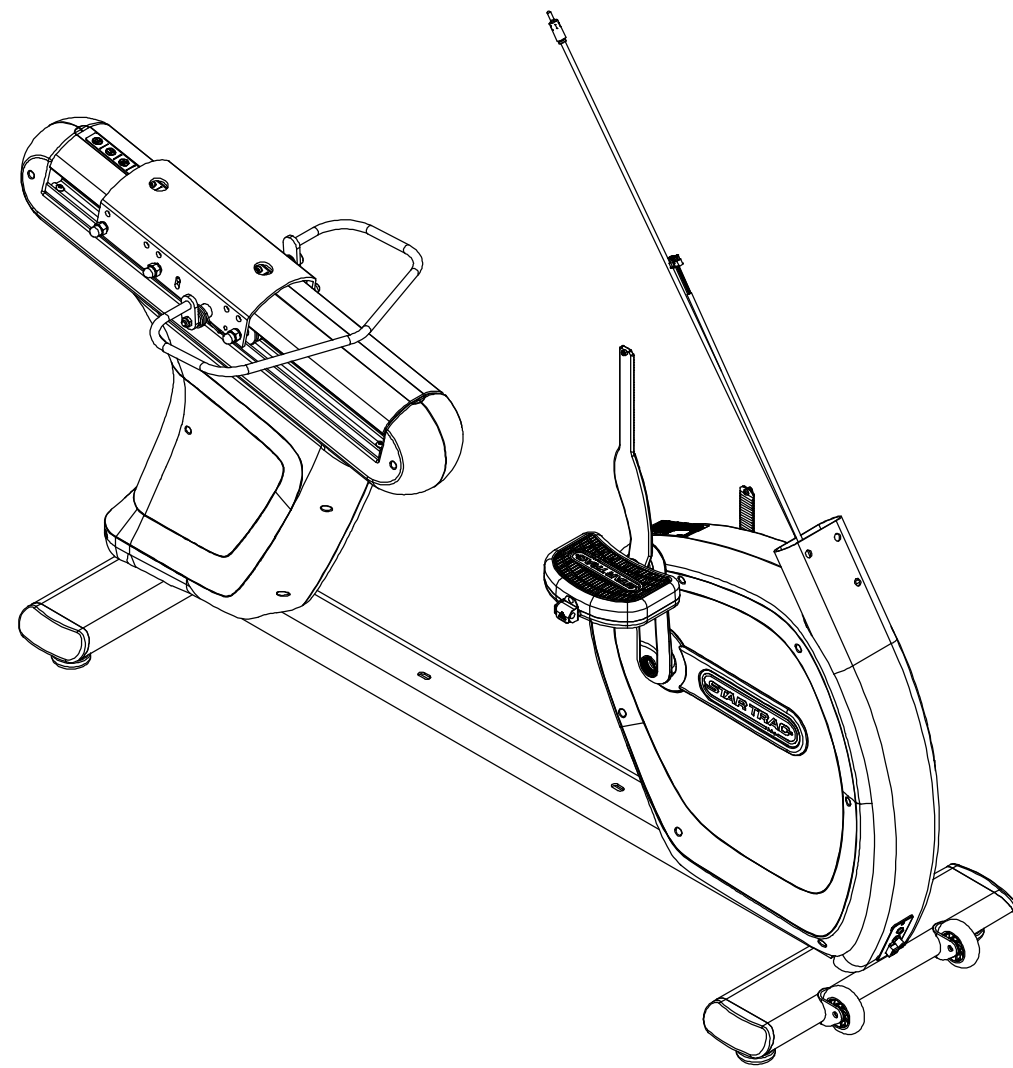

ITEM NO.	PART NUMBER	DESCRIPTION	QTY.
1	110-3164	SCREW, M4x0.7x16L,PHT,PH,CS,ZI	19
2	110-3167	SCREW, M4x0.7, 64mm,PHT,PH,CS,ZI	12
3	110-3171	SCREW, M6x20, SHC, HE, ISO4762	4
4	110-3177	SCREW, ISO4762, M5x16	2
5	110-3179	SCREW, ISO4762, M12x35	2
6	110-3230	SCREW, M5x18, SHC, HE, ISO4762	1
7	110-3236	NUT, M6xP1.0, UNLOCK	4
8	110-3469	SCREW, M6 X 1.0, 10mm, SHC, HK, NP	4
9	120-3246	WASHER, ISO 7089 - M6	4
10	120-3247	WASHER, ISO7089, M12	2
11	120-3252	WASHER, M5, ISO 7089	1
12	120-3254	SPACER, SHROUD, RB, PRO BIKE	2
13	120-3255	WASHER, M12, LOCK, ISO	2
14	130-1699	BELT, RB PRO	1
15	140-3243	SPRING, EXT	1
16	140-3248	SPACER, BRACKET, IDLER	3
17	140-3250	BRACKET, ANGLE, 4M	2
18	718-1087	GENERATOR, HYBRID BRAKE, UB/RB PRO	1
19	718-5251	ASSY, SHROUD, REAR, LT, R-BIKE, GEN 2	1
20	718-5253	SHROUD, REAR, RIGHT, R-BIKE, GEN 2	1
21	718-5254	ASSY, SHROUD, FRONT, LT, R-BIKE, GEN 2	1
22	718-5256	SHROUD, FRONT, RIGHT, R-BIKE, GEN 2	1
23	718-5258	KEY, DIE CAST, E-BIKES, GEN 2	2
24	718-5261-01	ASSY, PEDAL W/ STRAP, L, TAPER, E-BIKES, GEN 2	1
25	718-5261-02	ASSY, PEDAL W/ STRAP, R, TAPER, E-BIKES, GEN 2	1

ITEM NO.	PART NUMBER	DESCRIPTION	QTY.
26	718-5264	CRANK ARM, E-BIKES, GEN 2	2
27	718-5266	ASSY, BB, TAPER, E-BIKES, GEN 2	1
28	718-5267	PULLEY, 8J, 200mm OD, UNIV. E-BIKES	1
29	718-5268	BB, SPACER, E-BIKES, GEN 2	1
30	718-5269	ASSY, IDLER, E-RB, GEN 2	1
31	718-5277	NUT, AXLE, B/B, E-/S- BIKE, GEN 2	1
32	718-5296	WELDMENT, FRAME, S-RB, GEN 2	1
33	718-5333	ENDCAPS, SUPPORT, S-BIKE, GEN 2	4
34	718-5339	ASSY,EXTERNAL, CONN, S-BIKES G2	1
35	720-5074	ASSY,SEAT TRACK,RB,8020	1
36	730-1666	WASHER,PLAIN,M6	5
37	731-0373	WASHER,PLAIN,M6	4
38	731-0374	SCREW,M6 X 1.0,16mm,BHC,HK	5
39	731-0513	STICKER,STAR TRAC,DECO,45MMX191MM	2
40	740-0002	ASSY, LCB W/HEATSINK, S-BIKE	1
41	740-4011	CABLE, MAIN I/O, LOWER, S-UBx/S-RBx	1
42	740-7023	ASSY, FOOT, W/ OVER MOLD	4
43	740-7173	NUT, 1/2-13, HEX, CS, BO	4
44	740-7187	SCREW, M6X1.25X10, BHC, HE, SS	2
45	740-7553	BEARING, 6005 SERIES, 25x47x12, 2RS	2
46	740-7916	M5 X 16MM, DOWEL PIN	2
47	740-8006	WHEEL, FRONT FOOT, SPINNER	2
48	740-8007	BOLT, WHEEL, NXT	2
49	740-8145	SCREW, M8x1.25, 14mm, BB AXLE	4

NOTES:

DOCUMENT STATUS:

CLASS OF WORK	UNLESS OTHERWISE SPECIFIED DIMS ARE IN mm. TOLERANCES FOR MEASURE OF LENGTH ARE:							ANGLES = ±2°
	0.5 to 3	> 3 to 6	> 6 to 30	> 30 to 120	> 120 to 400	> 400 to 1000	> 1000 to 2000	
FINE	±0.05	±0.05	±0.1	±0.15	±0.2	±0.3	±0.5	----
MEDIUM	±0.1	±0.1	±0.2	±0.3	±0.5	±0.8	±1.2	±2
COARSE	±0.2	±0.3	±0.5	±0.8	±1.2	±2	±3	±4
VERY COARSE	----	±0.5	±1	±1.5	±2.5	±4	±6	±8

MATERIAL
SEE BOM

FINISH
NONE

VENDOR: **LAND AMERICA** P/N:

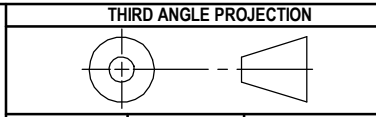

THIRD ANGLE PROJECTION	
DRAWN	DATE
SCN	10/10/2011
CHECKED	
APPROVED	

CORE INDUSTRIES, INC. DBA
STAR TRAC
14410 Myford Road
Irvine CA 92606

STARTRAC PART NO: **718-5332** REV: **B**

TITLE: **ASSY, BASE FRAME,S-RB , GEN 2**

SCALE: 1:10 SHEET 1 OF 3 SHEET SIZE: B

NOTICE OF PROPRIETARY INFORMATION
THIS DOCUMENT SHALL NOT BE REPRODUCED NOR SHALL THE INFORMATION CONTAINED HEREIN BE USED BY OR DISCLOSED TO OTHER EXCEPT AS EXPRESSLY AUTHORIZED BY CORE INDUSTRIES, INC., D.B.A. STAR TRAC.

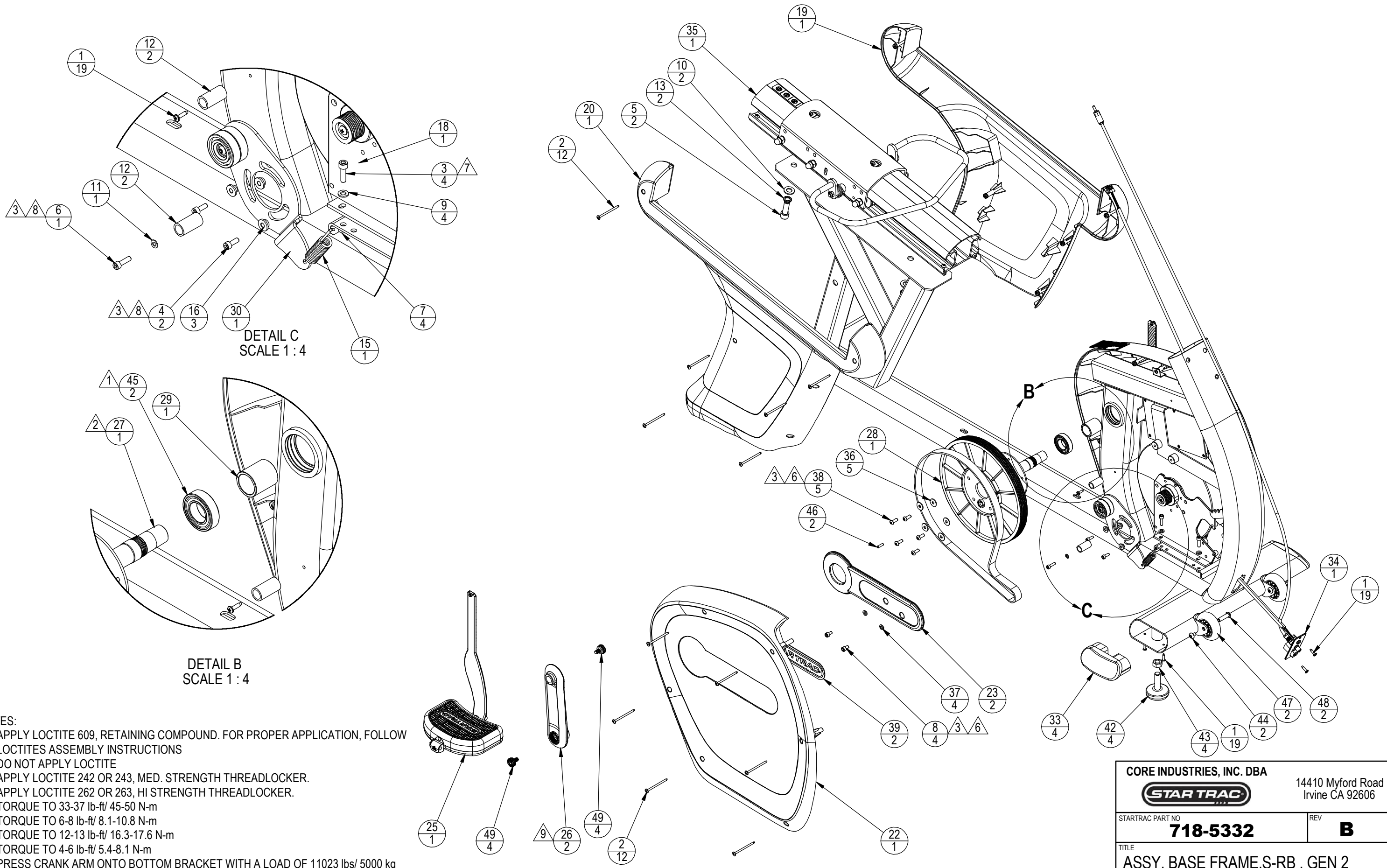

- NOTES:
1. APPLY LOCTITE 609, RETAINING COMPOUND. FOR PROPER APPLICATION, FOLLOW LOCTITES ASSEMBLY INSTRUCTIONS
 2. DO NOT APPLY LOCTITE
 3. APPLY LOCTITE 242 OR 243, MED. STRENGTH THREADLOCKER.
 4. APPLY LOCTITE 262 OR 263, HI STRENGTH THREADLOCKER.
 5. TORQUE TO 33-37 lb-ft/ 45-50 N-m
 6. TORQUE TO 6-8 lb-ft/ 8.1-10.8 N-m
 7. TORQUE TO 12-13 lb-ft/ 16.3-17.6 N-m
 8. TORQUE TO 4-6 lb-ft/ 5.4-8.1 N-m
 9. PRESS CRANK ARM ONTO BOTTOM BRACKET WITH A LOAD OF 11023 lbs/ 5000 kg
 10. TORQUE TO 48-50 lb-ft/ 65-67.8 N-m

CORE INDUSTRIES, INC. DBA		14410 Myford Road
STARTRAC		Irvine CA 92606
STARTRAC PART NO	718-5332	REV B
TITLE ASSY, BASE FRAME, S-RB, GEN 2		
SCALE: 1:8	SHEET 2 OF 3	SHEET SIZE: B

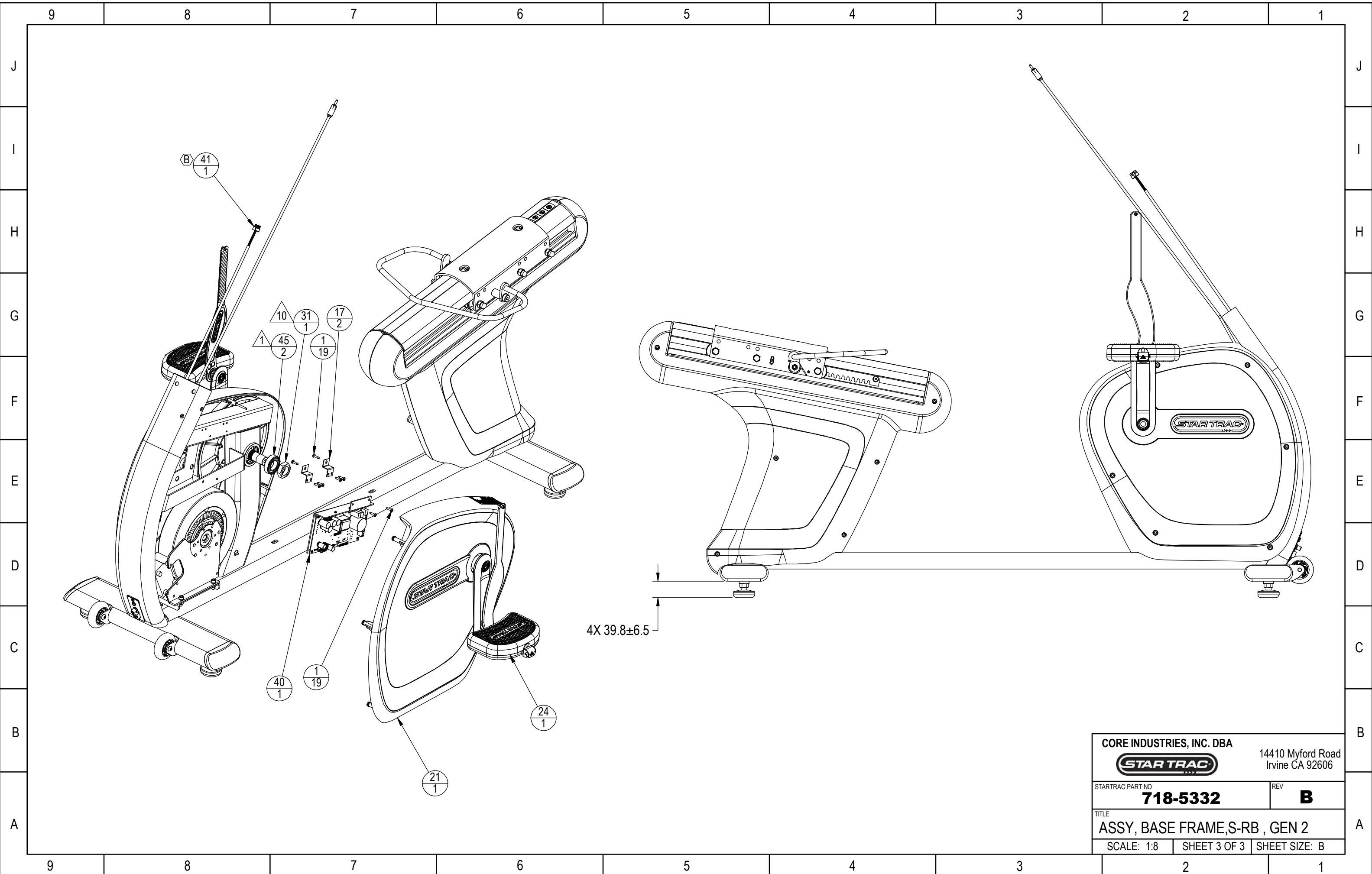

CORE INDUSTRIES, INC. DBA		14410 Myford Road
STAR TRAC		Irvine CA 92606
STARTRAC PART NO	718-5332	REV B
TITLE ASSY, BASE FRAME,S-RB , GEN 2		
SCALE: 1:8	SHEET 3 OF 3	SHEET SIZE: B