



LATERAL RAISE

OWNER'S MANUAL

REVISED: Sept. 15, 1998

SERIAL NO.'S

through

Contents

Parts Manual

- 1 WORKBOX ASSEMBLY
- 2 MOVEMENT ARM ASSEMBLY
- 3 SEAT ASSEMBLY
- 4 BELT & PULLEY ASSEMBLY
- 5 WEIGHT STACK ASSEMBLY
- 6 WEIGHT STACK ASSEMBLY
- 7 PARTS LIST
- 8 PARTS LIST

Maintenance Manual

Follows page 8

See last pages of this manual for 2ST Strength Circuit Exercise Order Diagram and 2ST Floor Plan Kit.



PARTS AND SERVICE
 709 Powerhouse Road
 Independence, Virginia 24348
 800-235-2233
 Fax: 540-773-2298

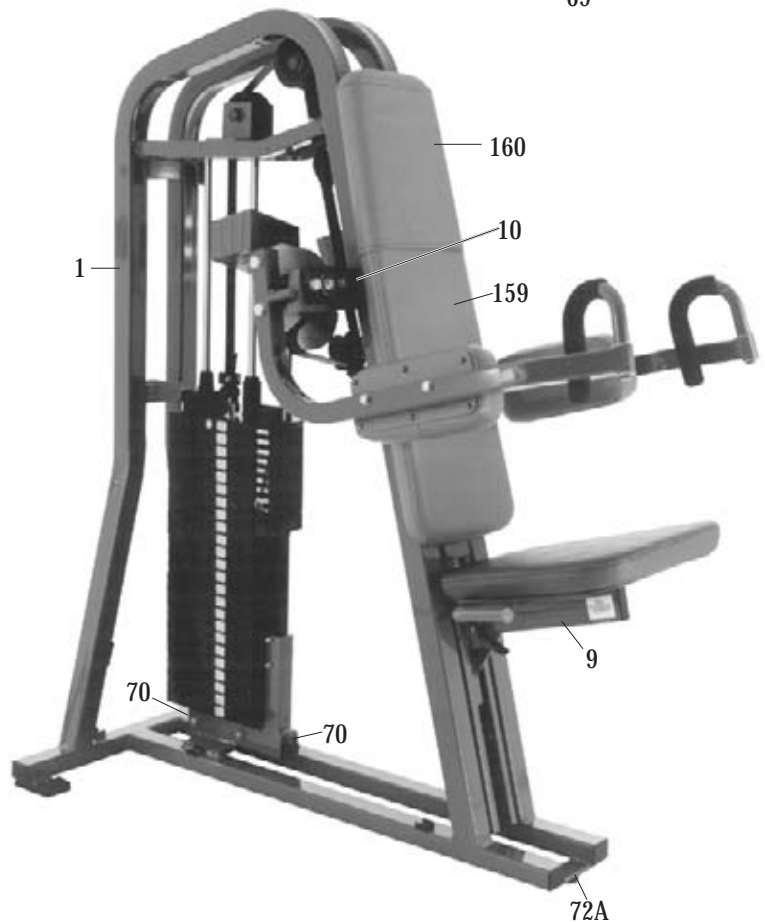

19-4926

WORKBOX ASSEMBLY

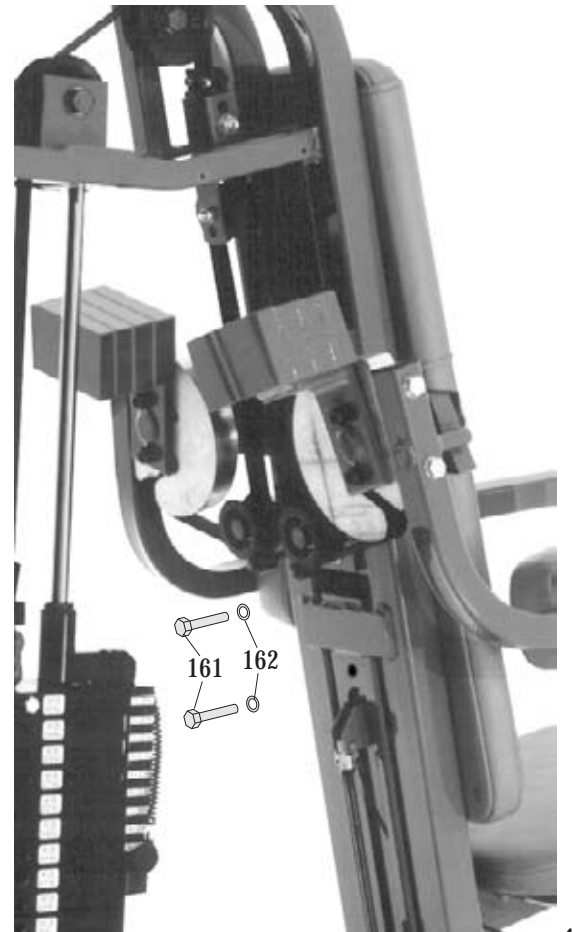
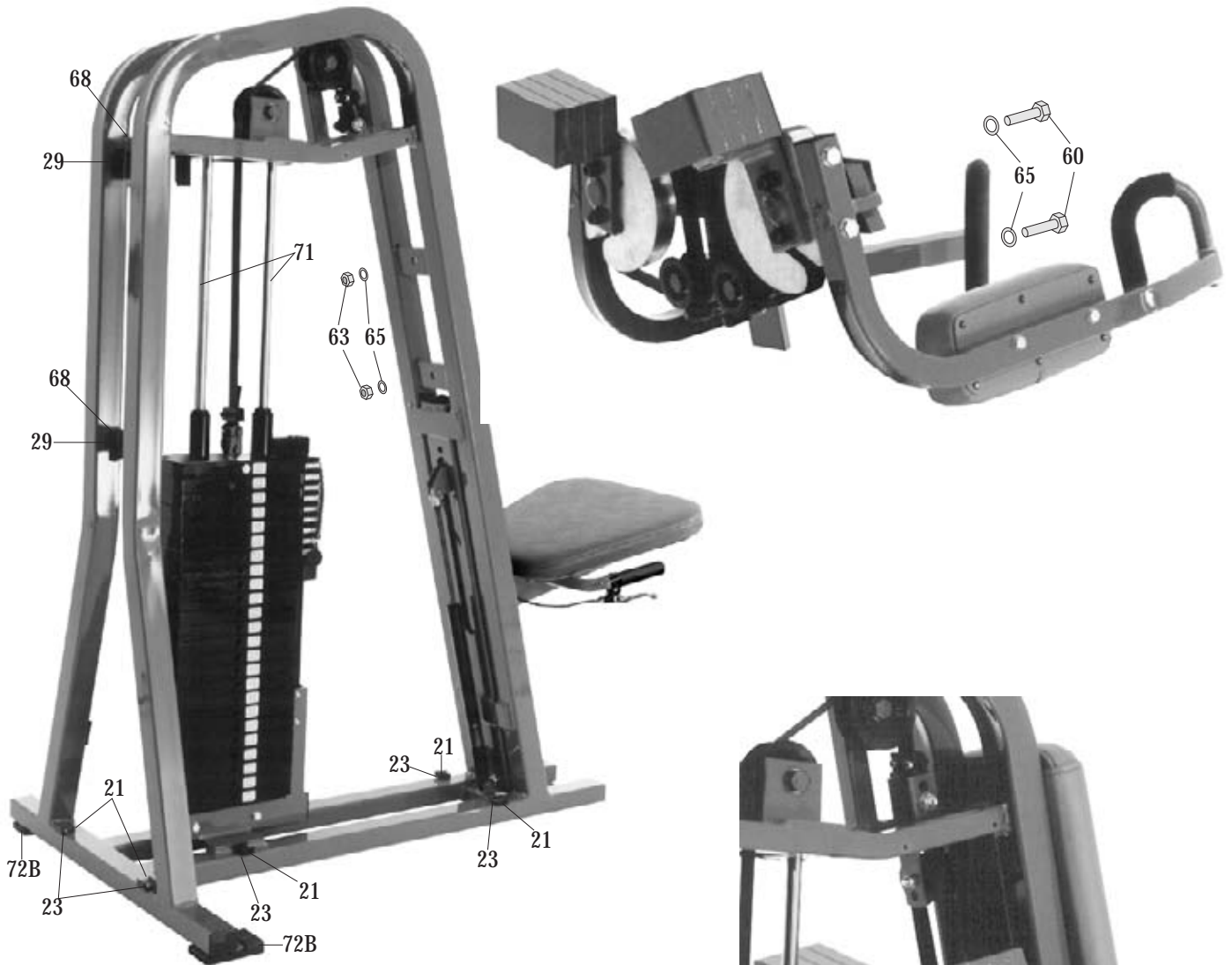

**MOVEMENT ARM
ASSEMBLY**

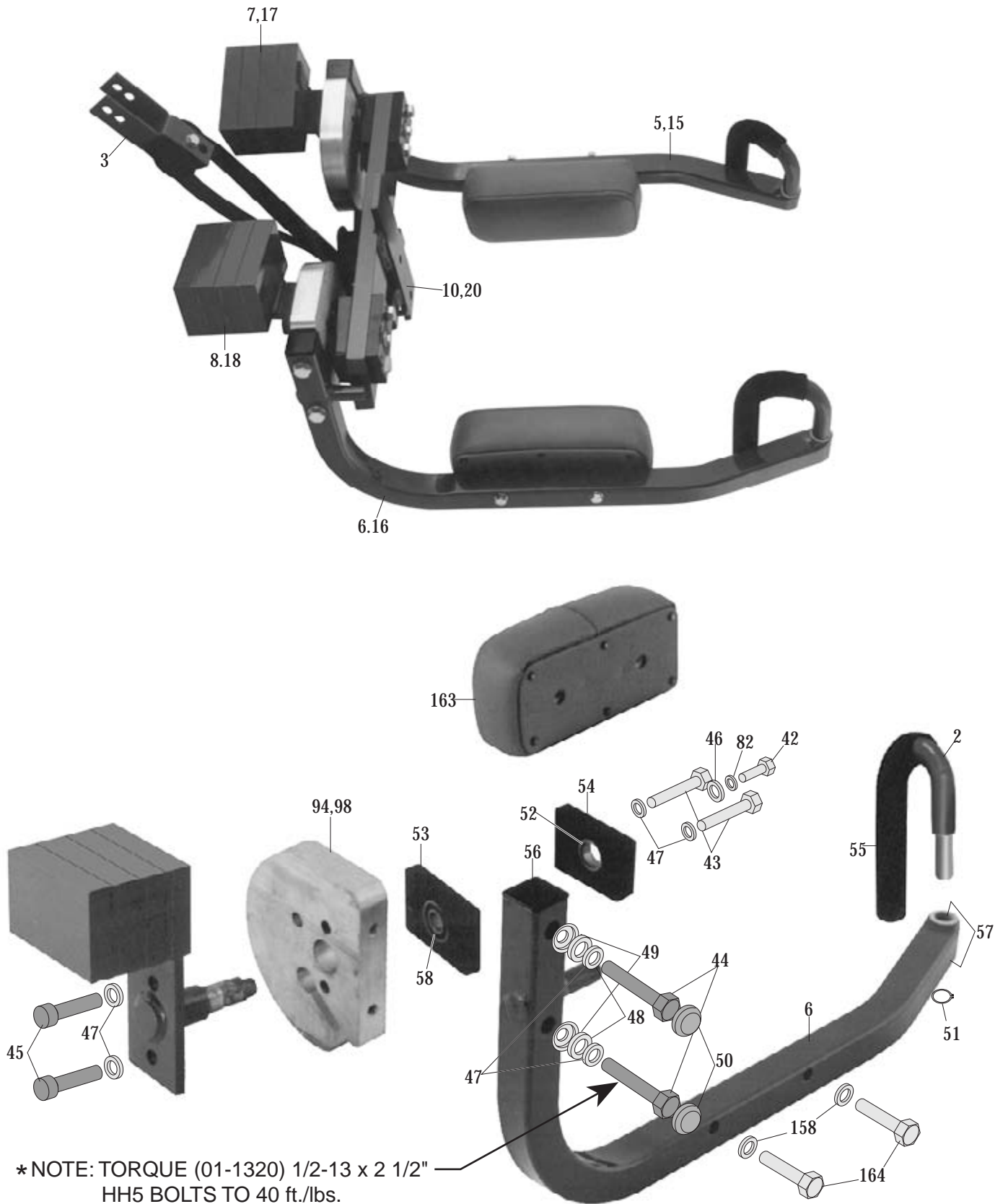

* NOTE: TORQUE (01-1320) 1/2-13 x 2 1/2"
HH5 BOLTS TO 40 ft./lbs.

SEAT ASSEMBLY

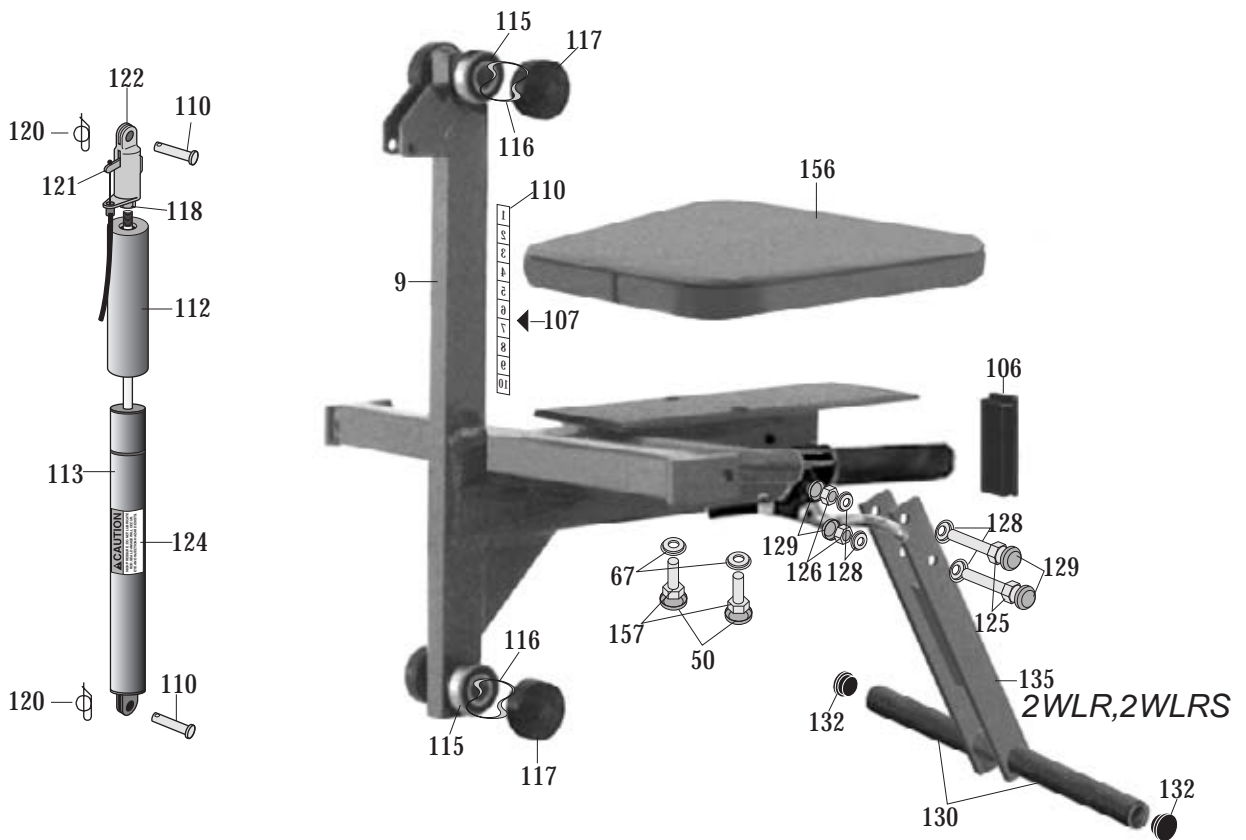
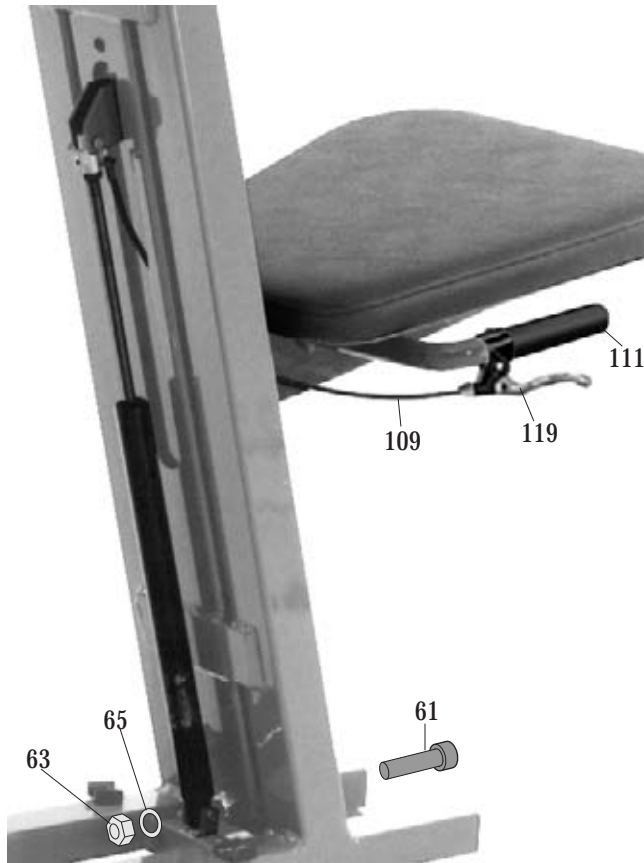

BELT & PULLEY ASSEMBLY

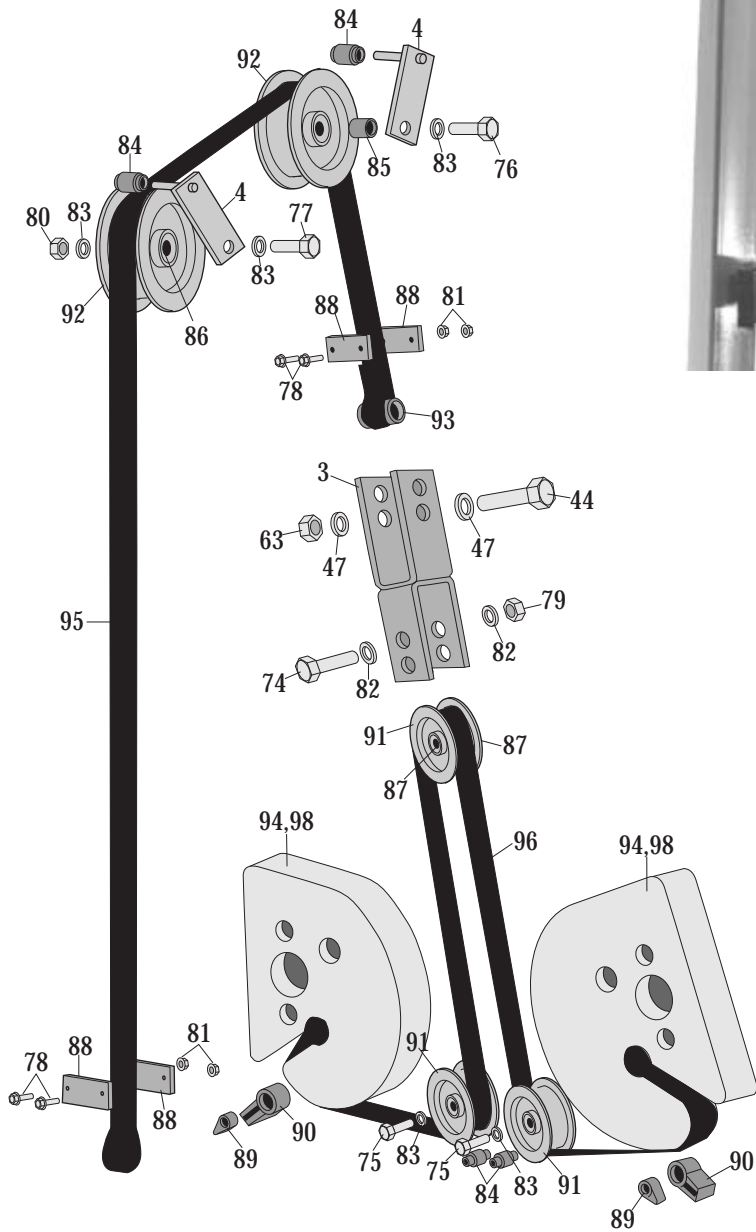
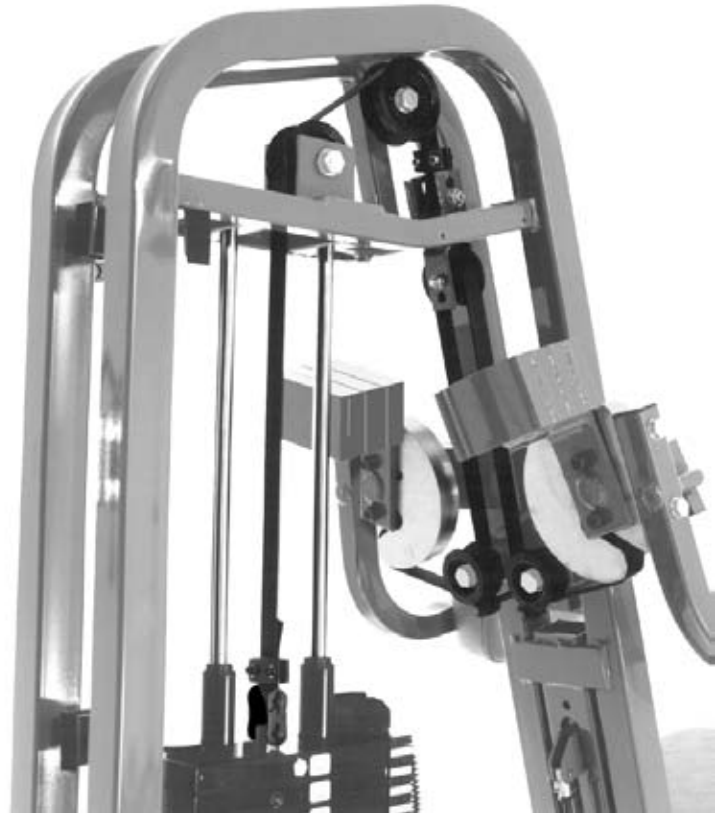

24 WEIGHT STACK



**USE CAUTION
WHEN WORKING
WITH WEIGHT
STACK !**

STANDARD

REF #	PART #	DESCRIPTION
A	01-0010	200 lb. WEIGHT STACK (20-200)
A	01-0010	BOLT HH2 7/16-14 X 4 1/2 BLACK
B	02-9190	1/4-20 X 3/4 FLANGE BUTTON HD. SCREW
C	03-1045	NUT NTE 7/16 BLACK
D	04-5070	RUBBER WEIGHT STACK WASHER
E	05-4020	BOTTOM WEIGHT BUSHING
F	05-4055	TOP WEIGHT BUSHING
G	06-2005	CHAIN LINK #100 CONNECTING LINK
H	06-7064	COIL SUPER 6"
I	06-8150	1 1/4 EXTERNAL SNAP RING
J	06-8254	SNAP RING 1"
K	07-4000	NYLINER PLASTIC BUSHING
L	07-8296	PIN WEIGHT SELECTOR W/MAGNET 4" LENGTH
M	07-9268	TOP WEIGHT SLEEVE
N	09-3066	HOLE PLUG 1 1/4 DIA WHITE
O	09-6135	BELT ROLLER
P	12-1024	DECAL WARNING 3"
Q	12-1052	WEIGHT STACK DECAL 20-250 lbs
R	12-1062	WEIGHT STACK DECAL 9.1 - 113.7 kg
S	17-2204	1 X 4 X 9.330 TOP WEIGHT STEEL, 10 lbs.
T	17-2206	1 X 4 X 9.330 SECOND WEIGHT STEEL, 10 lbs.
U	17-2203	1 X 4 X 9.330 BOTTOM WEIGHT STEEL, 10 lbs
V	17-2203	1 X 4 X 9.330 BOTTOM WEIGHT STEEL, 10 lbs
W	17-4115	WEIGHT STACK PIN 24 HOLE
X	BSF509	WEIGHT STACK STAND 8"
Y	07-9269	3" WEIGHT STACK SPACER
Z	09-2060	1 1/2 X 3" HOLE PLUG

WOMEN'S/MEDICAL

REF #	PART #	DESCRIPTION
A	01-0010	130 lb. WEIGHT STACK (10-130)
A	01-0010	BOLT HH2 7/16-14 X 4 1/2 BLACK
B	02-9190	1/4 X 1/2 PAN HD TYPE "F" SCREW BLACK
C	03-1045	NUT NTE 7/16 BLACK
D	04-5070	RUBBER WEIGHT STACK WASHER
E	05-4020	BOTTOM WEIGHT BUSHING
F	05-4055	TOP WEIGHT BUSHING
G	06-2005	CHAIN LINK #100 CONNECTING LINK
H	06-7064	COIL SUPER 6"
I	06-8150	1 1/4 EXTERNAL SNAP RING
J	06-8254	SNAP RING 1"
K	07-4000	NYLINER PLASTIC BUSHING
L	07-8296	PIN WEIGHT SELECTOR W/MAGNET 4" LENGTH
M	07-9268	TOP WEIGHT SLEEVE
N	09-3066	HOLE PLUG 1 1/4 DIA WHITE
O	09-6135	BELT ROLLER
P	12-1024	DECAL WARNING 3"
Q	12-1056	WEIGHT STACK DECAL 10-180 lbs
R	12-1061	WEIGHT STACK DECAL 4.6 - 81 kg
S	17-2210	1 X 4 X 9.330 TOP WEIGHT ALUM., 3.5 lbs.
T	17-2212	1 X 4 X 9.330 SECOND WEIGHT ALUM., 3.5 lbs.
U	17-2211	1 X 4 X 9.330 BOTTOM WEIGHT ALUM., 3.5 lbs.
V	17-2203	1 X 4 X 9.330 BOTTOM WEIGHT STEEL, 10 lbs.
W	17-4115	WEIGHT STACK PIN 24 HOLE
X	BSF509	WEIGHT STACK STAND 8"
Y	07-9269	3" WEIGHT STACK SPACER
Z	09-2060	1 1/2 X 3" HOLE PLUG

SUPER STACK

REF#	PART #	DESCRIPTION
A	01-0010	290 lb. WEIGHT STACK (20-290)
A	01-0010	BOLT HH2 7/16-14 X 4 1/2 BLACK
B	02-9190	1/4 X 1/2 PAN HD TYPE "F" SCREW BLACK
C	03-1045	NUT NTE 7/16 BLACK
D	04-5070	RUBBER WEIGHT STACK WASHER
E	05-4020	BOTTOM WEIGHT BUSHING
F	05-4055	TOP WEIGHT BUSHING
G	06-2005	CHAIN LINK #100 CONNECTING LINK
H	06-7064	COIL SUPER 6"
I	06-8150	1 1/4 EXTERNAL SNAP RING
J	06-8254	SNAP RING 1"
K	07-4000	NYLINER PLASTIC BUSHING
L	07-8297	PIN WEIGHT SELECTOR W/MAGNET 7" LENGTH
M	07-9268	TOP WEIGHT SLEEVE
N	09-3066	HOLE PLUG 1 1/4 DIA WHITE
O	09-6135	BELT ROLLER
P	12-1028	DECAL WARNING 6"
Q	12-1057	WEIGHT STACK DECAL 20-365 lbs
R	12-1064	WEIGHT STACK DECAL 9.1 - 165.9 kg
S	17-2204	1 X 4 X 9.330 TOP WEIGHT STEEL, 10 lbs.
T	17-2207	1 X 6 X 9.330 SECOND WEIGHT STEEL, 15 lbs.
U	17-2205	1 X 6 X 9.330 BOTTOM WEIGHT STEEL, 15 lbs.
V	17-2205	1 X 6 X 9.330 BOTTOM WEIGHT STEEL, 15 lbs.
W	17-4115	WEIGHT STACK PIN 24 HOLE
X	BSF509	WEIGHT STACK STAND 8"
Y	07-9269	3" WEIGHT STACK SPACER
Z	09-2060	1 1/2 X 3" HOLE PLUG

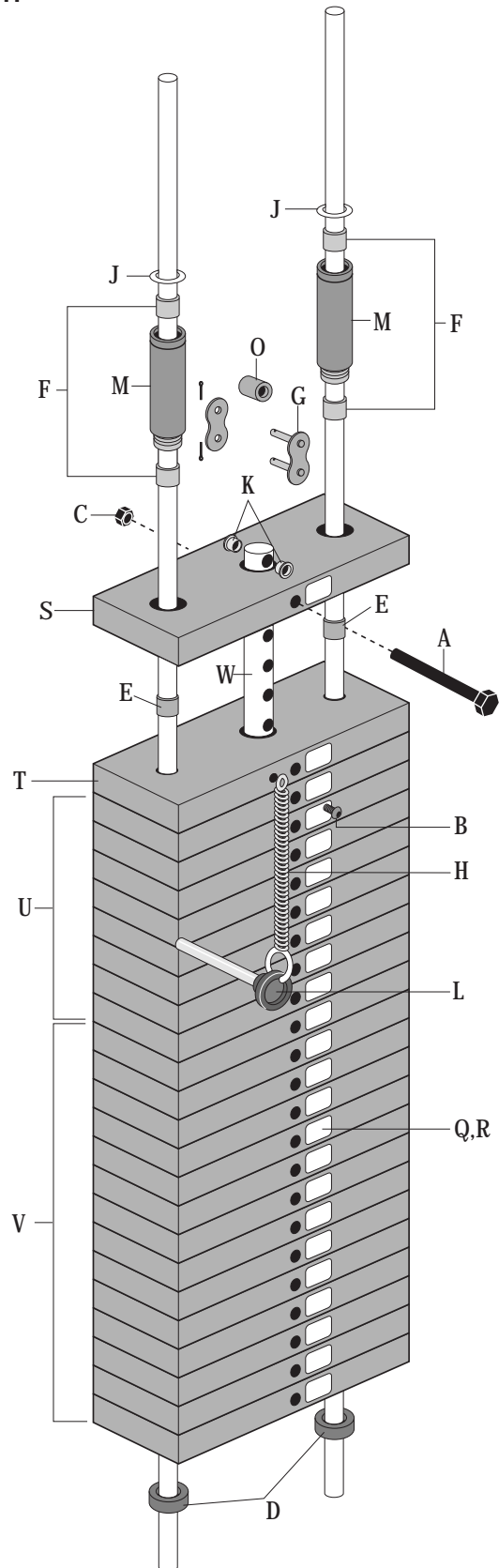

MINI 24 ADD-ON WEIGHT KIT LATERAL RAISE

REF #	PART #	DESCRIPTION
AA	01-1545	3/8-16 X 1/2 HEX BOLT BLACK
BB	01-1151	3/8-16 X 2-3/4 HEX BOLT BLACK
CC	01-4035	1/4 X 1-1/4 WIZ BOLT BLACK
DD	02-4134	1/4 X 1/2 PAN HD TYPE "F" SCREW BLACK
EE	02-9250	3/8 X 2 1/4 HEX BOLT BLACK
FF	03-1035	3/8 WIZ NUT BLACK ZINC
GG	03-4290	1/4 WIZ NUT BLACK ZINC
HH	04-5207	1/2 SAE FLAT WASHER BLACK
II	04-5225	1/4 LOCK WASHERS
JJ	04-5214	1/2 LOCK WASHERS BLACK
KK	06-7062	.450 OD 5" SUPER COIL
LL	07-5083	MINI WEIGHT BRACKET LR-PF
MM	07-8045	ADD ON WEIGHT SELECTOR PIN & KNOB
NN	07-9245	MOLDED WEIGHT STAND INSERT
OO	07-9250	MOLDED ADD-ON-WEIGHT BASE
PP	07-9255	MOLDED ADD-ON-WEIGHT LINK
QQ	07-9292	STANDARD MINI WT. STACK PIN
RR	09-3072	HOLE PLUG 3/8" BLACK
SS	12-1063	ADD ON WEIGHT DECAL KG
TT	12-1066	ADD ON WEIGHT DECAL LBS
UU	17-5998	CAST ADD-ON SECOND PLATE
VV	17-5999	CAST ONE POUND WEIGHT
WW	17-6015	RECTANGULAR WEIGHT BUSHING
XX	BSF514	MINI-WEIGHT STAND LR-PF

NO WEIGHT STAND:
2LR, 2PF
YY 07-9292 SHORT MINI WEIGHT STACK PIN
ZZ BSF514 SHORT MINI WEIGHT STAND

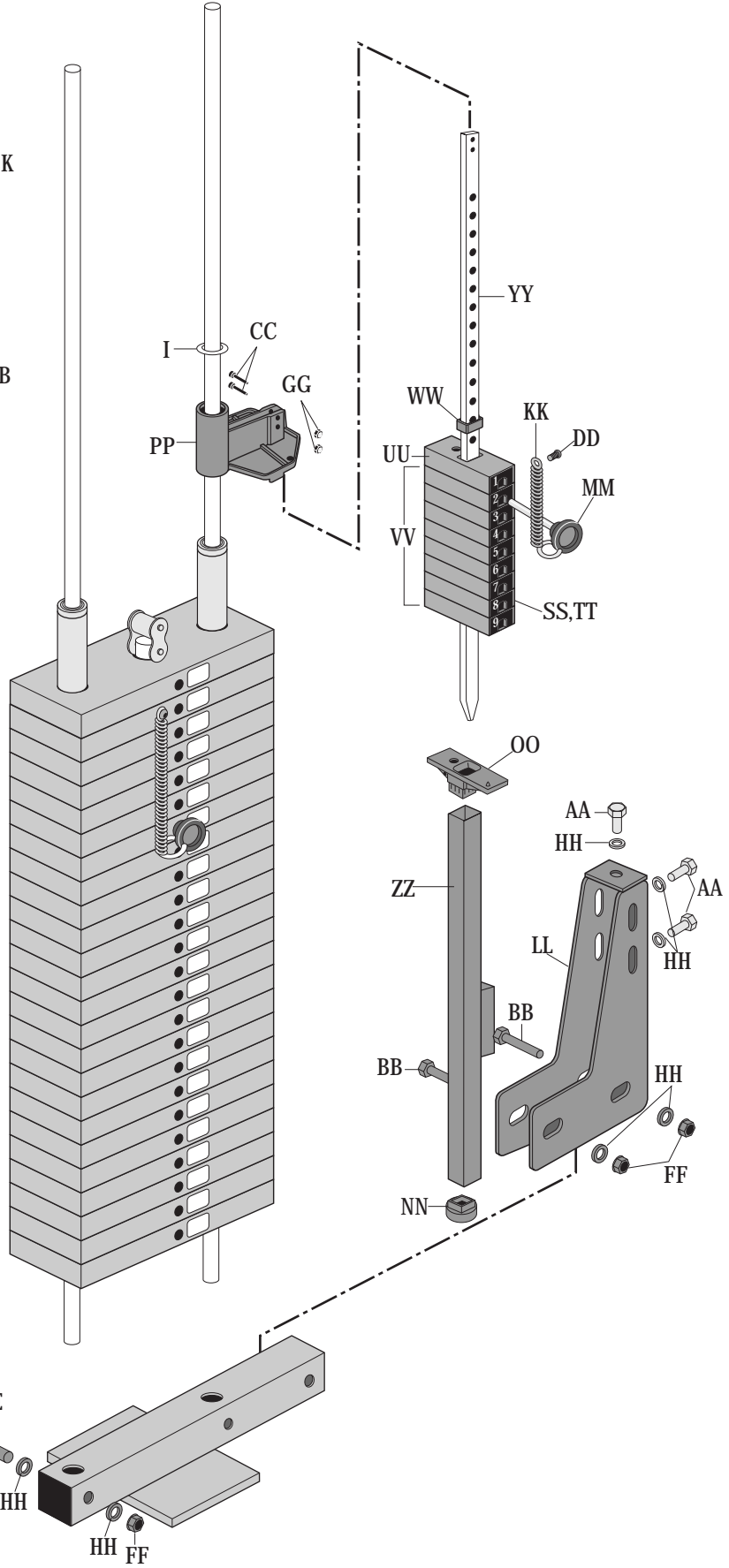

**USE CAUTION
WHEN WORKING
WITH WEIGHT
STACK !**

2ST LATERAL RAISE

E.L. CODES:

2LRS FULLY SHIELDED LATERAL RAISE
 2WLRS FULLY SHIELDED WOMENS' LATERAL RAISE
 2MLRS FULLY SHIELDED MEDICAL LATERAL RAISE
 2LR PARTIAL SHIELDED LATERAL RAISE
 2WLR PARTIAL SHIELDED WOMENS' LATERAL RAISE
 2SLR PARTIAL SHIELDED SUPER LATERAL RAISE

REF# PART# DESCRIPTION

E.L. CODE: 2LRS, 2MLRS, 2LR, 2SLR
 WL09 WELDMNT KIT LATERAL RAISE
 1.....BF504.....BACK FRAME ASSEMBLY
 2.....HB08.....HANDLE BAR ASSEMBLY
 3.....IB400.....IDLER BRACKET ASSEMBLY
 4.....LK529.....ANTI-JUMP PIN ASSEMBLY
 5.....MA508.....LEFT MOVEMENT ARM ASSEMBLY
 6.....MA509.....RIGHT MOVEMENT ARM ASSEMBLY
 7.....MA510.....LEFT MOVEMENT ARM COUNTER WEIGHT ASSEMBLY
 8.....MA511.....RIGHT MOVEMENT ARM COUNTER WEIGHT ASSEMBLY
 9.....SE502.....SEAT ASSEMBLY
 10.....WB502.....WORKBOX ASSEMBLY

E.L. CODE: 2WLR, 2WLR
 WL10 WELDMNT KIT LATERAL RAISE WOMENS
 11.....BF504.....BACK FRAME ASSEMBLY
 12.....HB08.....HANDLE BAR ASSEMBLY
 13.....IB400.....IDLER BRACKET ASSEMBLY
 14.....LK529.....ANTI-JUMP PIN ASSEMBLY
 15.....MA541.....LEFT MOVEMENT ARM WOMENS ASSEMBLY
 16.....MA542.....RIGHT MOVEMENT ARM WOMENS ASSEMBLY
 17.....MA543.....LEFT WOMENS MA COUNTER WEIGHT ASSY.
 18.....MA544.....RIGHT WOMENS MA COUNTER WEIGHT ASSY
 19.....SE502.....SEAT ASSEMBLY
 20.....WB511.....WORKBOX ASSEMBLY

E.L. CODE: 2LRS, 2WLRS, 2MLRS
 SH39 SHIELD KIT 2LRS
 21.....02-4134.....1/4 X 1/2 PAN HD. TYPE "F" CUTTING SCREW
 22.....03-4030.....NUT INSERT 1/4-20 X 1/2 ALUMINUM
 23.....07-5416.....BOLT ON SHLD MNT
 24.....07-9014.....SHIELD STANDOFF 5/8 OD X 7 1/2 L
 25.....14-2031.....RIGHT SIDE SHIELD
 26.....14-2032.....BACK SHIELD
 27.....14-2033.....RIGHT WORK BOX SHIELD
 28.....14-2049.....LEFT SIDE SHIELD
 29.....19-1015.....2" SQ SERIES 170 DUAL LOC
 30.....19-1016.....1 X 2 RECT. SERIES 400 DUAL LOC

E.L. CODE: 2LR, 2WLR, 2SLR
 SH38 SHIELD KIT 2LR
 31.....03-4030.....NUT INSERT 1/4-20 X 1/2 ALUMINUM
 32.....07-9014.....SHIELD STANDOFF 5/8 OD X 7 1/2 L
 33.....14-2117.....BACK SHIELD
 34.....14-2118.....LEFT SIDE SHIELD
 35.....14-2119.....RIGHT SIDE SHIELD
 36.....19-1015.....2" SQ SERIES 170 DUAL LOC
 37.....19-1016.....1 X 2 RECT. SERIES 400 DUAL LOC

E.L. CODE: 2LRS, 2WLRS, 2MLRS, 2LR, 2WLR, 2SLR
 SH37 SHIELD KIT LATERAL RAISE
 38.....12-2776.....PLACARD LATERAL RAISE
 39.....12-1120.....RED PINE TREE CLIP
 40.....19-4926.....PARTS DIAGRAM LATERAL RAISE
 41.....02-4134.....SCREW SHIELD 1/4 X 3/4
 41A.....12-1026.....WARNING DECAL KEEP HANDS AWAY

REF# PART# DESCRIPTION

E.L. CODE: 2LRS, 2WLRS, 2MLRS, 2LR, 2WLR, 2SLR
 MV05 MOVEMENT ARM KIT LATERAL RAISE
 42.....02-9210.....3/8 X 1 HH5
 43.....01-1402.....1/2 X 2 1/4 HH5
 44.....01-1321.....1/2 X 2 1/2 HH5
 45.....02-4117.....1/2 X 1 1/4 AC
 46.....04-5206.....3/8 SAE FL. WASHER
 47.....04-5214.....WASHER INT LOK 1/2
 48.....04-5207.....1/2 SAE FLAT WASHER BLACK
 49.....04-5130.....1/2 BOLT CAP WASHER
 50.....04-5145.....PLASTIC BOLT CAP
 51.....06-8160.....3/4"EXTERNAL SNAP RING
 52.....07-5065.....203 PP BEARINGS 17MM
 53.....07-8402.....BEARING MTS. (25MM TAPPED)
 54.....07-8403.....BEARING MTS. (17MM ST. HOLE)
 55.....09-1070.....1 X 8.5 LR HANDLE GRIP
 56.....09-2020.....1 1/2 SQ. HOLE PLUG
 57.....45-1051.....BUSHING IGUS PLAIN LFI-1214-08
 58.....45-1063.....205 PP FAFNIR BEARING

E.L. CODE: 2LRS, 2WLRS, 2MLRS, 2LR, 2WLR, 2SLR
 FR10 FRAME KIT LATERAL RAISE
 59.....02-9250.....BOLT HH5 3/8 X 2 1/4
 60.....01-1271.....BOLT HH5 1/2 X 1 1/4
 61.....02-4115.....SCREW AC 1/2 X 3/4
 62.....03-1035.....NUT NTE 3/8
 63.....03-1055.....NUT NTE 1/2
 64.....03-1055.....NUT 1/2 BLACK
 65.....04-5214.....1/2 INT LOC WASHER
 66.....04-5214.....WASHER 1/2 INT LOC BLACK
 67.....04-5135.....3/8 BOLT CAP WASHER
 68.....09-2010.....1 1/4 SQ FRAME PLUG
 69.....09-2040.....1 1/2 X 2 FRAME CAP PLUGS
 70.....09-2070.....2 SQ FRAME PLUGS
 71.....17-1265.....GUIDE RODS 46" LONG
 72.....04-5145.....PLASTIC BOLT CAP
 72A.....09-5030.....ROUND FOOT PAD
 72B.....09-5035.....RECTANGLE FOOT PAD

E.L. CODE: 2LRS, 2WLRS, 2MLRS, 2LR, 2WLR, 2SLR
 BLT10 BELT & PULLEY KIT LATERAL RAISE
 73.....02-9250.....BOLT HH5 3/8 X 2 1/4
 74.....01-1115.....BOLT HH5 3/8 X 2 1/2
 75.....01-2180.....BOLT HH5 5/8 X 1 1/2 BLACK
 76.....01-2185.....BOLT HH5 5/8 X 2 1/2 BLACK
 77.....01-2200.....BOLT HH5 5/8 X 3 1/2 BLACK
 78.....01-4030.....1/4 X 1 WHIZ FLANGE SM PATTERN BLACK
 79.....03-1035.....3/8 NTE
 80.....03-1067.....5/8 NTE
 81.....03-4290.....1/4-20 WHIZ FLANGE NUT L/N SM PATTERN
 82.....04-5213.....3/8 LOC WASH
 83.....04-5215.....5/8 LOC WASH
 84.....06-5045.....ANTI-JUMP ROLLER
 85.....07-5072.....ANTI-JUMP PIN SPACER
 86.....07-8344.....5/8 ID X 1 LONG PULLEY BUSHING
 87.....07-8346.....25/64 ID X 3/4 LONG PULLEY BUSHING
 88.....07-8982.....END STRAP CLAMP
 89.....08-7063.....TEARDROP (FOR CAM)
 90.....08-7064.....TEARDROP INSERT
 91.....09-8323.....2" PULLEY
 92.....09-8327.....3" PULLEY
 93.....09-8990.....STRAP END BUSHING NYLON
 94.....11-1581.....PC LR CAM MENS L&R
 95.....24-6030.....KEVLAR BELT 47" LONG
 96.....24-6030.....KEVLAR BELT 63" LONG

REF#	PART#	DESCRIPTION
	<i>E.L. CODE:</i> 2WLRS, 2WLR	
	CAM02	CAM KIT LATERAL RAISE WOMENS
97
9811-3372WOMENS CAMS L&R
99
10024-6030KEVLAR BELT 51 1/2" LONG WOMENS BELT

	<i>E.L. CODE:</i> 2LRS, 2WLRS, 2MLRS, 2LR, 2WLR, 2SLR	
	IN01	INSPECTION KIT
10112-1080INSPECTION STICKER DECAL
10212-1088DECAL NAUTILUS NAMEPLATE 2 1/2 x 9 1/4
10319-1291DECAL SERIAL # BAR CODE
10440-7167BAG 50 X 46 X 86 X .002 THICK

	<i>E.L. CODE:</i> 2LRS, 2LR, 2SLR	
	ST06	SEAT KIT 1
10509-30637/16" WHITE HOLE PLUG
10609-30801 X 3 HOLE PLUG
10712-1001SEAT POSITION INDICATOR ARROW
10812-1009SEAT DECAL 1 BOTTOM -10 TOP (5/8 WIDE)
10906-8006SEAT ADJUSTMENT CABLE, 18"
11007-8027PIN CLEVIS 5/16 X 1 3/16
11109-1058RUBBER HAND GRIP, 7/8 X 4 1/2
11207-9298GAS SPRING COVER TUBE
11307-9299GAS SPRING COVER PLUG
11410-3045RIGID IN COMPRESSION, 250 N #7613IL
11507-5065BEARING FAFNIR 203 PP
11610-401240 MM O.D. WAVE SPRING SSB-0158-S17
11719-1235NYLON SEAT ROLLERS
11803-1075NUT HEX 10MM
11906-8000SEAT ADJUSTMENT HANDLE 7/8"
12007-8135COTTER PIN #RUE-10 mfg. PIVOT POINT
12107-9201SHOCK LEVER P/N 783234
12207-9205HEAD THREAD ON CAST ALUM
12312-1109SEAT SHOCK ADJ. TAG
12412-1113SHOCK WARNING DECAL

	<i>E.L. CODE:</i> 2WLRS, 2MLRS, 2WLR	
	ST07	SEAT KIT 2
12501-11213/8 X 2 HH5
12603-10353/8 NTE
12704-52133/8 LOC WASH
12804-51353/8" BOLT CAP WASHER
12904-5145PLASTIC BOLT CAP
13009-11721 X 6 GRIP
13109-30801 X 3 HOLE PLUG
13209-30941.25 OD X .75 ID X .75 L HOLE PLUG
13312-1001SEAT POSITION INDICATOR ARROW
13412-1009SEAT DECAL 1 BOTTOM -10 TOP (5/8 WIDE)
135SE510WOMEN'S FOOTREST ASSEMBLY

	<i>E.L. CODE:</i> 2LRS, 2WLRS, 2MLRS, 2LR, 2WLR, 2SLR	
	UPH07	LATERAL RAISE UPHOLSTERY KIT
156UP8015SEAT PAD
15701-1105BOLT HH5 3/8 X 1 1/2 BLACK
15804-5213WASHER INT LOK 3/8 BLACK
159UP8210BACK PAD
160UP720SLIPCOVER
16101-1550BOLT HH5 3/8 X 3 BLACK
16204-5213WASHER INT LOK 3/8 BLACK
163UP8230MA ELBOW PAD
16401-1115BOLT HH5 3/8 X 2 1/2 BLACK
16504-5213WASHER INT LOK 3/8 BLACK

	<i>E.L. CODE:</i> 2LR, 2WLR, 2SLR	
16609-3067HOLE PLUG WHITE 1/4"

REF#	PART#	DESCRIPTION
	<i>E.L. CODE:</i> 2WLRS, 2WLR	
	IN01	INSPECTION KIT
16712-1175NAUTILUS WOMEN'S NAMEPLATE 2 1/2 x 9 1/4