

This document contains information proprietary to Magnum Fitness Systems. It is submitted in confidence and is to be used solely for the purpose for which it is furnished. This document and such information is not to be reproduced, transmitted, or used in whole or part without written authorization.

TOLERANCES: + 0.000"
- 1/16"

UNLESS OTHERWISE SPECIFIED
DIMENSIONS ARE IN INCHES.

DRAWN BY:
Josh Ellis

MAGNUM FITNESS SYSTEMS
2201 12th. Avenue
S. Milwaukee, WI, 53172

TITLE: 414 - Biangular Shoulder Press

DATE:
08/13/07

PART NO.
xxx-xxx

JOB NO.
XXXXXXXX

REV:
1

FILE LOCATION: C:\Cad Drawings\Solid Works\

1 OF 2

ITEM NO.	QTY.	PART NO.	DESCRIPTION
1	1	100-839	Main Frame
2	2	851-317	1" PILLOW BLOCK
3	1	100-840	Right Arm
4	1	100-857	H-Brace
5	1	100-841	Left Arm
6	2	200-388	1" CRR - 5"
7	4	851-416	FLANGE BEARING - 1"
8	6	819-316	1" Ext. SNAP RING
9	6	850-006	2" X 3" END CAP
10	2	250-399	3/4"OD x 7/16"ID PIPE - 7"
11	1	339-708	SEAT POST - CHROMED
12	6	850-004	2" x 2" END CAP
13	1	900-196	Back Pad
14	1	900-005	UPHOLSTERY
15	2	858-260	2" x 2" RUBBER BUMPER
16	4	858-252	2 1/2"OD x 1"ID RUBBER DOUGHNUT - 1/2"
17	2	850-030	Bullet End Cap
18	2	858-253	2 1/2"OD x 1 7/8"ID RUBBER BUMPER - 1/2"
19	1	101-411	Lever Lock Assembly
20	2	855-154f	Ball Joint (Female Half)
21	2	855-154m	Ball Joint (Male half)
22	2	855-156m	Ball Joint (Male Half)
23	2	855-156f	Ball Joint (Female Half)(Threaded Left Handed)

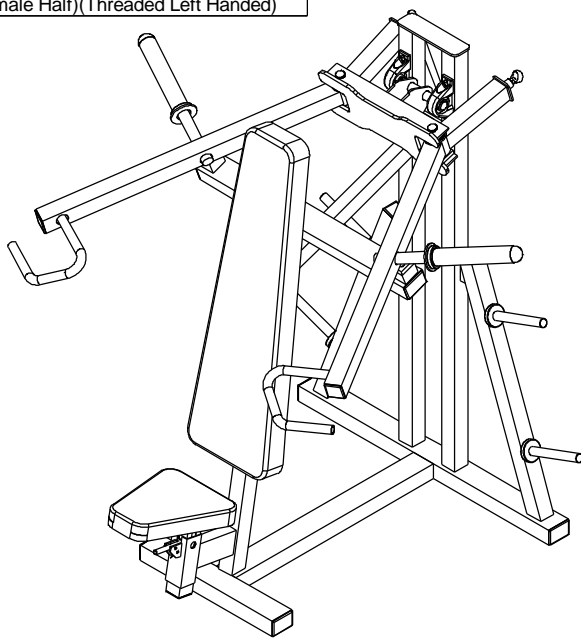

<p>This document contains information proprietary to Magnum Fitness Systems. It is submitted in confidence and is to be used solely for the purpose for which it is furnished. This document and such information is not to be reproduced, transmitted, or used in whole or part without written authorization.</p>	<p>TOLERANCES: + 0.000" - 1/16"</p>		<p>MAGNUM FITNESS SYSTEMS 2201 12th. Avenue S. Milwaukee, WI, 53172</p>		
	<p>UNLESS OTHERWISE SPECIFIED DIMENSIONS ARE IN INCHES.</p>		<p>TITLE: 414 - Biangular Shoulder Press</p>		
<p>DRAWN BY: Josh Ellis</p>	<p>DATE: 08/13/07</p>	<p>PART NO. xxx-xxx</p>	<p>JOB NO. XXXXXXXX</p>	<p>REV: 1</p>	
<p>FILE LOCATION: C:\Cad Drawings\Solid Works\</p>				<p>2 OF 2</p>	