

This document contains information proprietary to Magnum Fitness Systems. It is submitted in confidence and is to be used solely for the purpose for which it is furnished. This document and such information is not to be reproduced, transmitted, or used in whole or part without written authorization.

TOLERANCES: + 0.000"
- 1/16"

MAGNUM FITNESS SYSTEMS

2201 12th. Avenue
S. Milwaukee, WI, 53172

TITLE: M61 - Adjustable Decline / Sit Up

UNLESS OTHERWISE SPECIFIED
DIMENSIONS ARE IN INCHES.

DRAWN BY:
Josh Ellis

DATE:
03/27/06

PART NO.
xxx-xxx

JOB NO.
XXXXXXXX

REV:
1

FILE LOCATION: C:\Cad Drawings\Solid Works\

1 OF 2

ITEM NO.	QTY.	PART NO.	DESCRIPTION
1	1	100-636	Frame - Bottom
2	1	100-637	Frame - Top
3	1	100-638	ADJUSTMENT TUBE
4	1	339-910	Chrome Slide
5	6	850-004	2" x 2" END CAP
6	1	900-017	Upholstery - Back Pad
7	1	900-018	Upholstery - Bent Pad
8	2	902-007	9" ROLLER PAD
9	2	836-215	ROLLER END CAP w/ 2" HOLE
10	2	836-216	ROLLER END CAP w/ 5/16" HOLE
11	1	852-826	SHOCK
12	2	850-503	Wheel
13	2	851-505	Flange Bushing - 3/4"OD x 1/2"ID
14	1	401-140	SPRING PIN ASSEMBLY

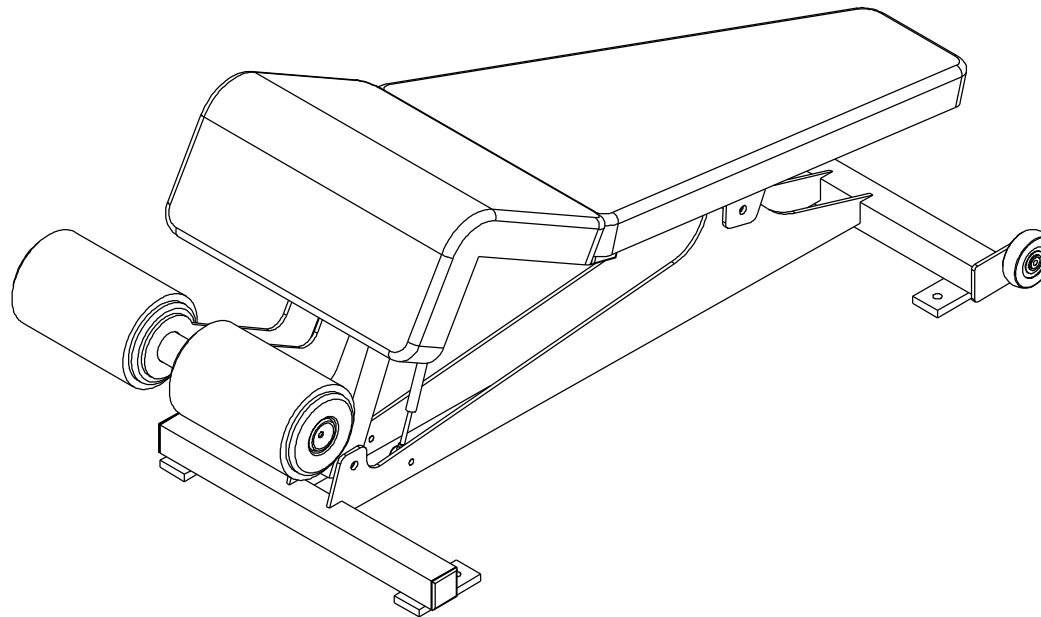

This document contains information proprietary to Magnum Fitness Systems. It is submitted in confidence and is to be used solely for the purpose for which it is furnished. This document and such information is not to be reproduced, transmitted, or used in whole or part without written authorization.

TOLERANCES: + 0.000"
- 1/16"

UNLESS OTHERWISE SPECIFIED
DIMENSIONS ARE IN INCHES.

DRAWN BY:
Josh Ellis

MAGNUM FITNESS SYSTEMS
2201 12th. Avenue
S. Milwaukee, WI, 53172

TITLE: M61 - Adjustable Decline / Sit Up

DATE: 03/27/06	PART NO. xxx-xxx	JOB NO. XXXXXXXX	REV: 1
-------------------	---------------------	---------------------	-----------

FILE LOCATION: C:\Cad Drawings\Solid Works\

2 OF 2