

<p>This document contains information proprietary to Magnum Fitness Systems. It is submitted in confidence and is to be used solely for the purpose for which it is furnished. This document and such information is not to be reproduced, transmitted, or used in whole or part without written authorization.</p>	<p>TOLERANCES: + 0.000" - 1/16"</p>	<p>MAGNUM FITNESS SYSTEMS 2201 12th. Avenue S. Milwaukee, WI, 53172</p>		
	<p>UNLESS OTHERWISE SPECIFIED DIMENSIONS ARE IN INCHES.</p>	<p>TITLE: 4014 - Shoulder Press</p>		
<p>DRAWN BY: Josh Ellis</p>	<p>DATE: 2/15/06</p>	<p>PART NO. xxx-xxx</p>	<p>JOB NO. XXXXXXXX</p>	<p>REV: 1</p>
<p>FILE LOCATION: C:\Cad Drawings\Solid Works\</p>				<p>1 OF 2</p>

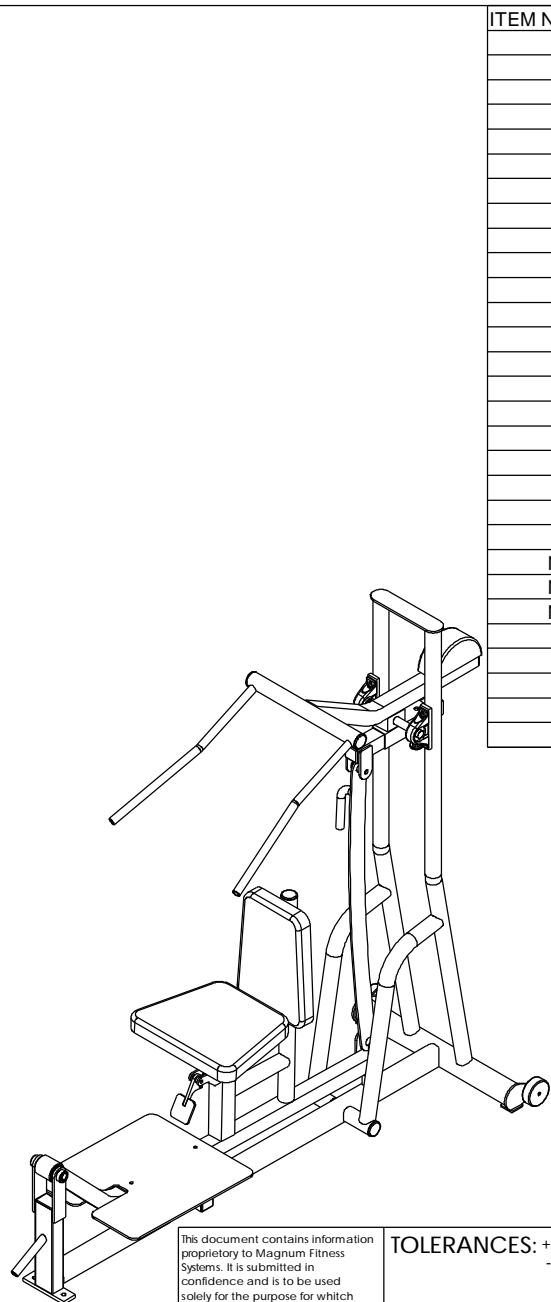

ITEM NO.	QTY.	PART NO.	DESCRIPTION
1	1	101-422	Main Frame
2	1	101-459	Sub Frame
3	1	101-460	Slide
4	1	101-461	Linkage
5	1	101-462	Arm Assembly
6	2	851-317	1" PILLOW BLOCK
7	1	501-537	DIAMOND PLATE
8	1	339-702	ADJUSTMENT POST - CHROMED
9	1	200-455	8" CRR - 3 1/4"
10	1	901-054	UPHOLSTERY
11	1	901-055	UPHOLSTERY
12	2	850-504	3 1/2" WHEEL
13	1	850-006	2" X 3" END CAP
14	5	850-004	2" x 2" END CAP
15	5	850-035	2" ROUND END CAP
16	2	851-416	FLANGE BEARING - 1"
17	1	101-513	Lever
18	2	851-552	3/8" FLANGE BUSHING - 3/8"
19	4	851-514	1/2" BRASS BUSHING
20	1	401-140	SPRING PIN ASSEMBLY
21	1	838-223	HALF-ROUND RUBBER BUMPER
NP	2	858-322	GRIP - 30"
NP	1	858-300	GRIP - 10"
NP	1	858-301	GRIP - 10" - RED
22	1	855-302	SPRING PIN w/ 5/32"
23	1	852-807	SPRING
24	1	817-306	3/8"-16 JAM NUT
25	1	700-534	MASTER LINK
26	1	852-826	SHOCK

This document contains information proprietary to Magnum Fitness Systems. It is submitted in confidence and is to be used solely for the purpose for which it is furnished. This document and such information is not to be reproduced, transmitted, or used in whole or part without written authorization.

TOLERANCES: + 0.000"
- 1/16"

UNLESS OTHERWISE SPECIFIED
DIMENSIONS ARE IN INCHES.

MAGNUM FITNESS SYSTEMS
2201 12th. Avenue
S. Milwaukee, WI, 53172

TITLE: 4014 - Shoulder Press

DRAWN BY:
Josh Ellis

DATE:
02/15/06

PART NO.
xxx-xxx

JOB NO.
XXXXXXXX

REV:
1

FILE LOCATION: C:\Cad Drawings\Solid Works\

2 OF 2