

# SECTION III

## How To...

# SERVICE AND REPAIR

	<b>Page</b>
Pedals, Crank Arms, and Side Shrouds.....	3
Crank Shaft Hub Assembly .....	5
Crank Shaft and Bearings .....	7
Clutch Assembly.....	10
Intermediate Pulley Shaft and Bearings .....	11
Idler Roller .....	16
Main Drive Belt.....	17
Alternator.....	18
Alternator Belt .....	19
Seat Post Assembly (Latch LC8500, 9100, 9500) .....	20
Seat Post Assembly (Pull-Pin C7 and C9) .....	21
Main Wire Harness.....	22
9 Volt Console Battery (LC8500 and C7).....	23
6 Volt Battery on Frame (LC9500, 9100, and C9).....	24
Display Console and Accessory Tray.....	25
Console Post Assembly, Main Cable, and Coax Cable for LCD .....	26
Power Control Board (LC8500 and C7) .....	27
Power Control Board (LC9500, 9100, and C9) .....	28
Pedal .....	29
Front Wheels.....	30
Handlebar Assembly .....	31
Heart Rate Sensor (LC9500 and C9).....	32
Telemetry Receiver LC9500, 9100, 8500, and C7).....	33
Resistor Assembly.....	34
Auto Start Switch.....	35
Console PCB.....	36
LCD Integrated Console Service Overview.....	37
Headphone Jack .....	38
Inverter Board.....	39
Single Board Computer .....	40
Interface Board.....	41
Touch Screen Assembly .....	42

***Lifecycle Upright Bikes LC95, LC91, LC85, C9, C7, 95Ce, 95Ci, 93Ci, and 90C***

**Notes:**

---

# Lifecycle Upright Bikes LC95, LC91, LC85, C9, C7, 95Ce, 95Ci, 93Ci, and 90C

## How To... Remove Pedals, Crank Arms, and Shrouds

Special Service Tools: NONE

NOTE: Each shroud can be removed independently of each other. This procedure covers removal of the right shroud first and then the left shroud. However, the order is not critical, but what is important, is to know that three screws secure the shrouds to the frame while the remaining five screws secures the shroud halves to each other. See illustration below.

1. Remove the mounting screw on the right side seat cover and then remove the seat post covers.

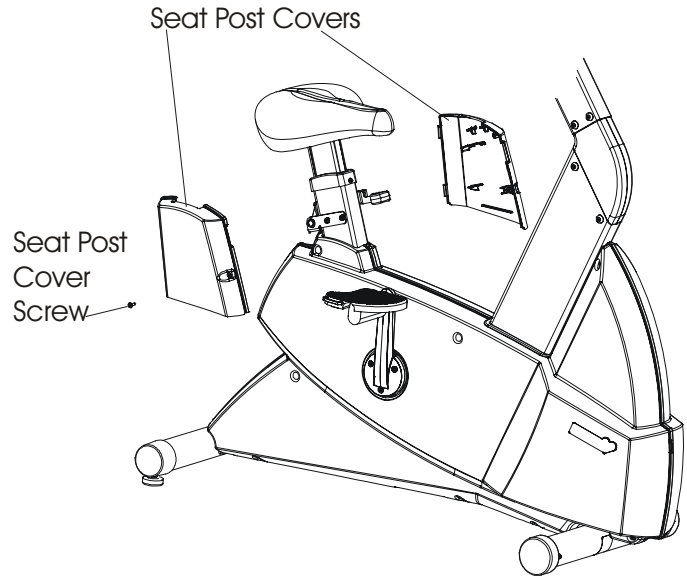

2. Remove three screws from the right crank arm, and then remove the right crank arm from the crank hub with pedal attached.

3. To remove the right shroud, remove eight screws as follows:

- Four screws at the bottom of the shroud
- One at the top rear of the shroud which are secured into the left shroud
- Three screws, as shown, which secure the right shroud to the frame.

4. After removing these screws, remove the right shroud from the unit. The left shroud will remain attached to the left side of the frame.

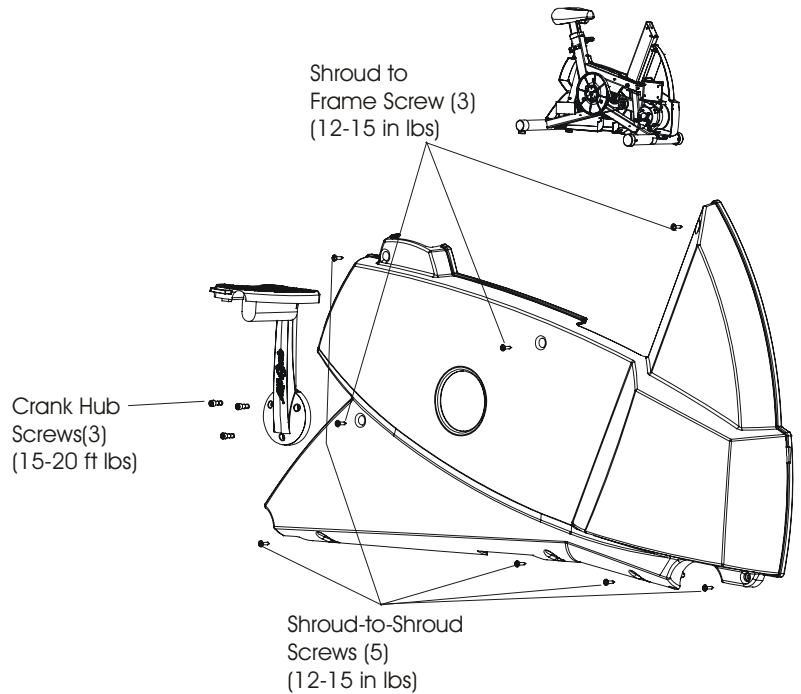

## Lifecycle Upright Bikes LC95, LC91, LC85, C9, C7, 95Ce, 95Ci, 93Ci, and 90C How To... Remove Pedals, Crank Arms, and Shrouds - Continued

**Special Service Tools: NONE**

---

4. Remove three screws from the left crank hub, and then remove the left crank arm from the crank shaft with pedal attached.
5. Remove the remaining three frame screws from the upper half of the left shroud, and then remove the left shroud.

Note: If only the left shroud needs removal, then remove the four lower screws and one screw in the top rear of the shroud from the right shroud which secures the two shroud halves together, and then remove the remaining three frame screws on the upper-side of the left shroud. See illustration on previous page.

6. Install shrouds in reverse order.
7. Torque the shroud screws 12-15 in lbs.
8. Torque crank hub screws 15-20 ft lbs. These screws can be reused up to 5 times before needing replacement. Torque the pedals 10-15 ft lbs if removed.

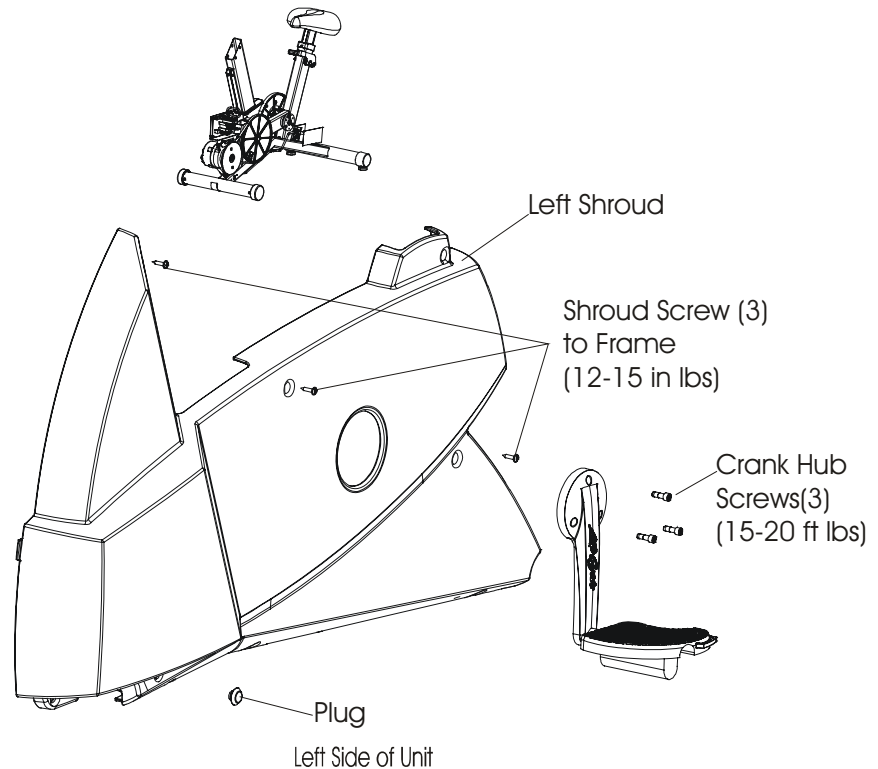

# Lifecycle Upright Bikes LC95, LC91, LC85, C9, C7, 95Ce, 95Ci, 93Ci, and 90C

## How To... Replace the Crank Shaft Hub Assembly

Special Service Tools: Bearing Service Tool Kit – Part Number: **BearingToolKit**

1. Remove the crank arm with pedal from the defective crank shaft hub.
2. Remove the side shrouds. Refer to How To...Remove Pedals, Pedal Levers, and Side Shrouds.
3. Remove the main drive belt. Refer to, How To...Remove Main Drive Belt.

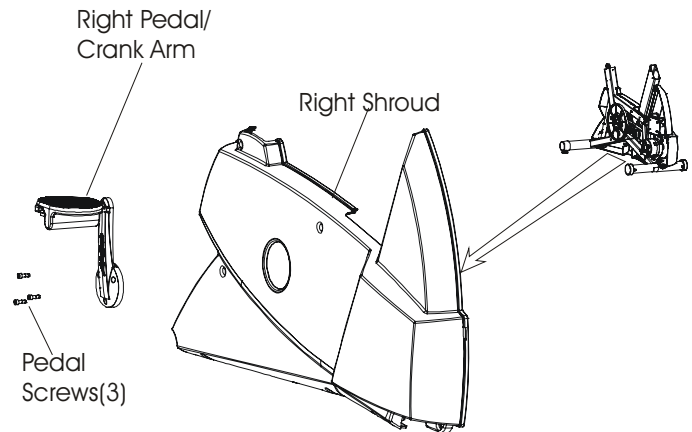

4. Remove the bolt and washer in the center of each hub.

NOTE: The arrow mark on the hub. The other hub also has same mark 180 degrees apart for proper crank arm location.

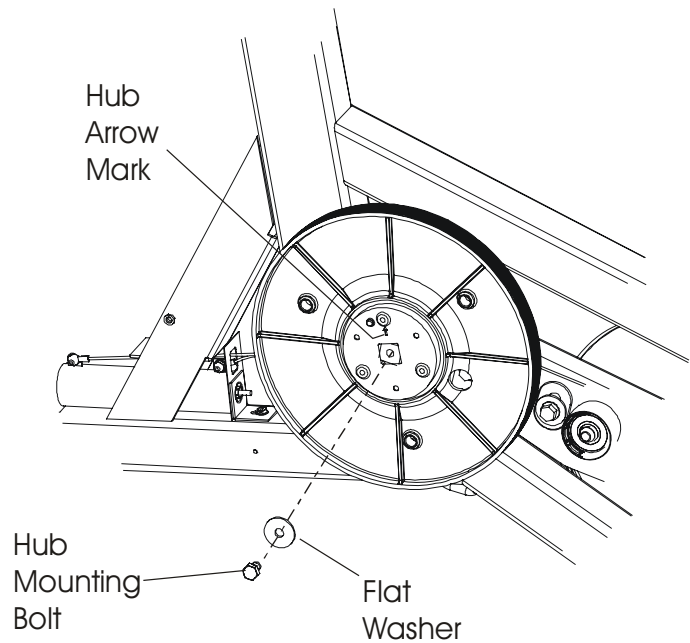

## Lifecycle Upright Bikes LC95, LC91, LC85, C9, C7, 95Ce, 95Ci, 93Ci, and 90C How To... Replace the Crank Shaft Hub Assembly - Continued

Special Service Tools: Bearing Service Tool Kit – Part Number: **BearingToolKit**

---

5. Install the disc puller plate as illustrated on the left hub.
6. Turn the puller forcing bolt clockwise until the left hub is removed. Discard the hub.

NOTE: The right hub is removed with the crank shaft pulley attached. Use the puller as described in left hub removal. Once off, remove the three screws at the back of the pulley to separate it from the hub.

NOTE: Make sure the arrow mark on the hub is pointing 180 degrees from the other hub.

7. Position the new hub on the crank shaft with the washer. Install the mounting bolts and tighten evenly until the hub is fully seated on the shaft. Torque: 220-240 in lbs. This bolt can be reused up to 5 times before needing replacing.

NOTE: If the right hub was replaced, then install the hub back on the pulley first and secure using the three mounting screws.

8. Reinstall the side shrouds, crank arms, and pedals.

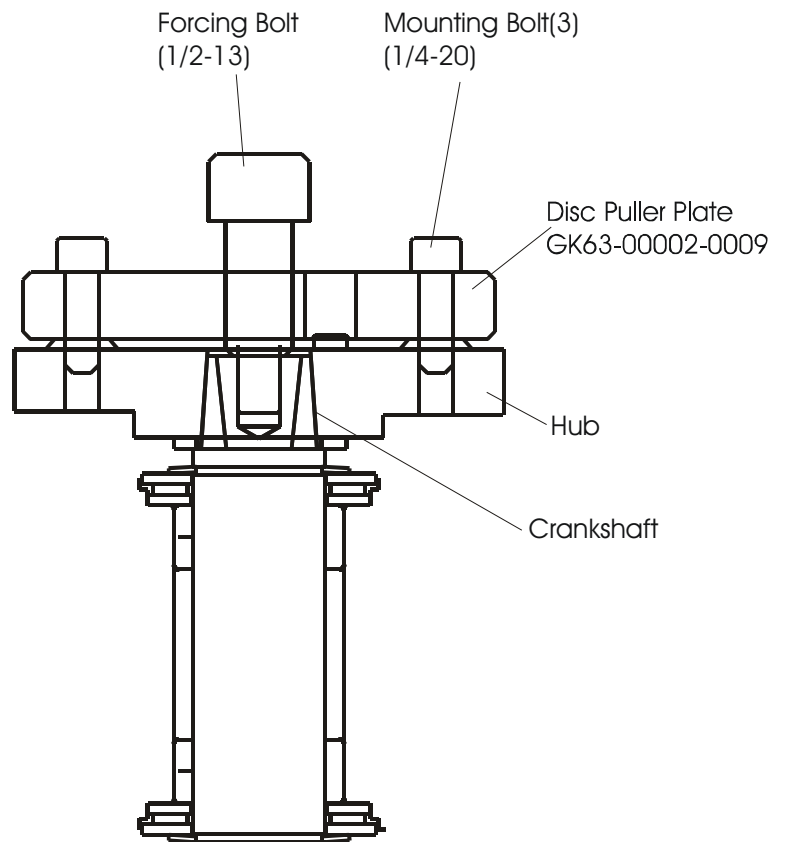

REMOVING THE HUB

**Lifecycle Upright Bikes LC95, LC91, LC85, C9, C7, 95Ce, 95Ci, 93Ci, and 90C**  
**How To... Replace the Crank Shaft Bearings**

**Special Service Tools: Bearing Service Tool Kit – Part Number: [BearingToolKit](#)**

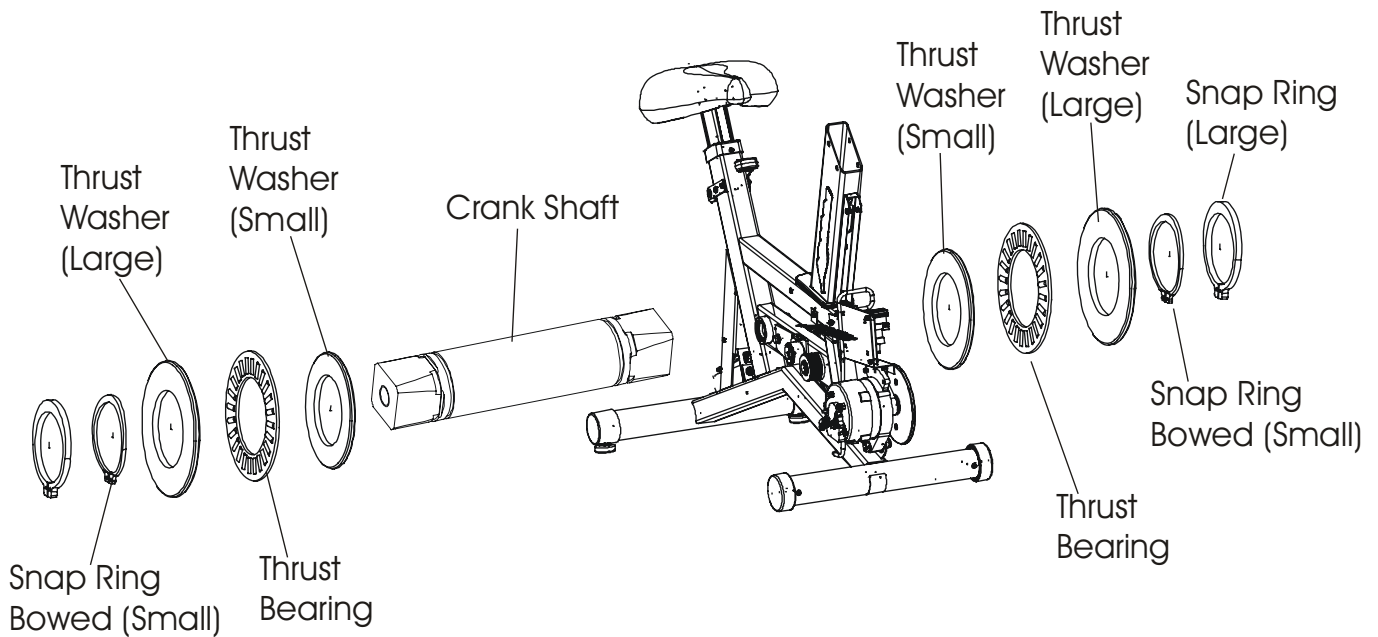

1. Remove the pedals, crank arms, and side shrouds. Refer to, How To... Remove Pedals, Pedal Levers, and Side Shrouds.
2. Remove the main drive belt. Refer to, How To...Remove Main Drive Belt.
3. Remove the crank shaft hubs. Refer to, How To...Remove Crank Shaft Hubs.
4. Remove the snap rings, large thrust washer, thrust bearing, and small thrust washer from both sides the crank shaft.
5. Push the crank shaft out from the frame bearings.
6. Inspect, and if necessary, replace any crank shaft component parts as necessary before reassembling onto the new crank shaft.
7. Install the bearing puller on the crank needle bearings as illustrated

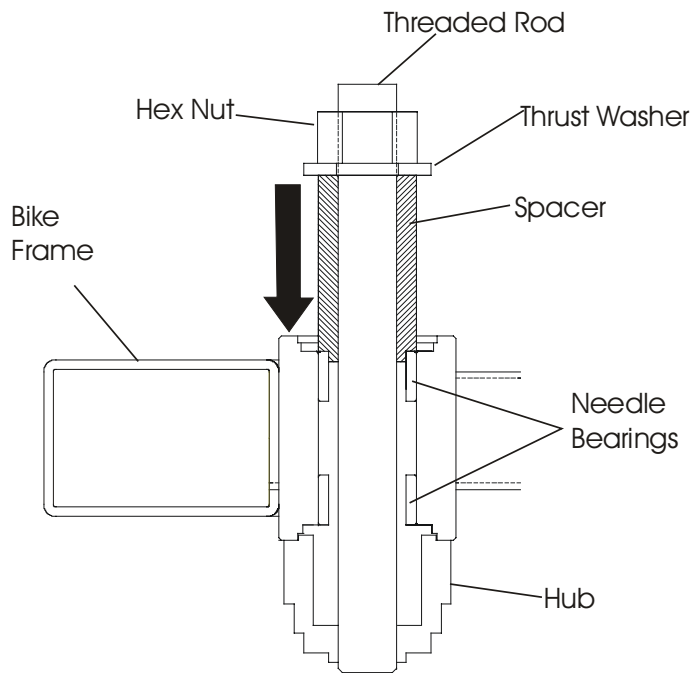

INSTALLING CRANK BEARING KIT

# Lifecycle Upright Bikes LC95, LC91, LC85, C9, C7, 95Ce, 95Ci, 93Ci, and 90C

## How To... Replace the Crank Shaft Bearings - Continued

Special Service Tools: Bearing Service Tool Kit – Part Number: **BearingToolKit**

- Press out the needle bearings by rotating the hex nut clockwise until the bearings drop into the puller hub. Once the bearings are out of the frame, disassemble the puller assembly, and discard the bearings.
- Clean the housing before installing new needle bearings.

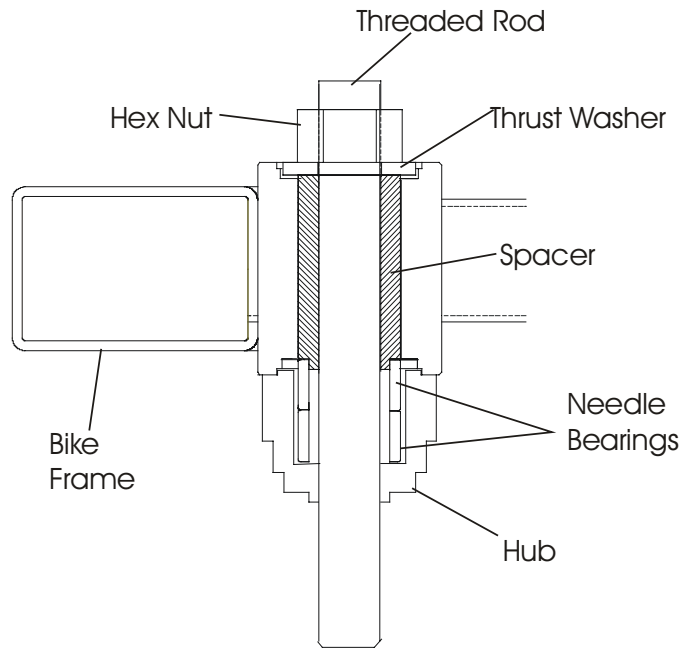

PUSHING OUT THE NEEDLE BEARINGS INTO THE HUB

- Position the new needle bearing with markings, on the face of the bearings, are positioned facing out. Make sure bearings are aligned straight and square.

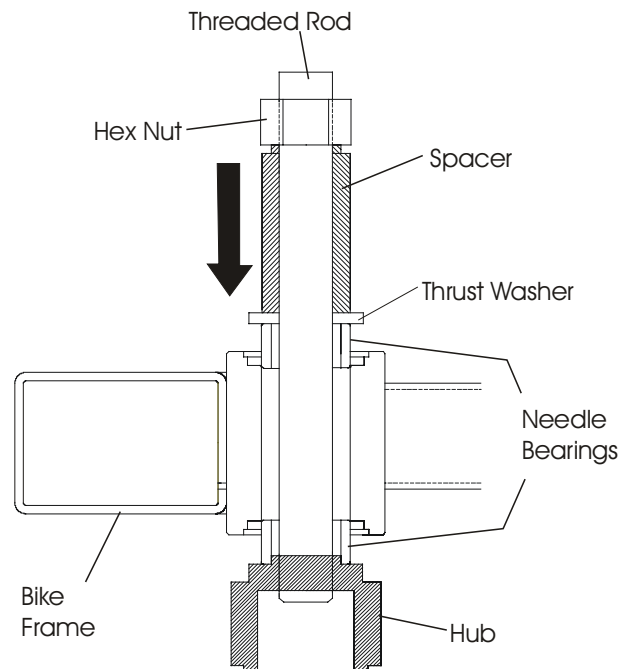

INSTALLING NEW NEEDLE BEARINGS



**Lifecycle Upright Bikes LC95, LC91, LC85, C9, C7, 95Ce, 95Ci, 93Ci, and 90C**  
**How To... Replace the Crank Shaft Bearings - Continued**

**Special Service Tools: Bearing Service Tool Kit – Part Number: [BearingToolKit](#)**

11. Start tightening the hex nut. You may have to hold the spacer to stop it from turning.
12. Continue pressing in the new needle bearings until the thrust washer and hub stop against the frame housing shoulder. Make sure that the bearing races seat flush against the inner hub face.

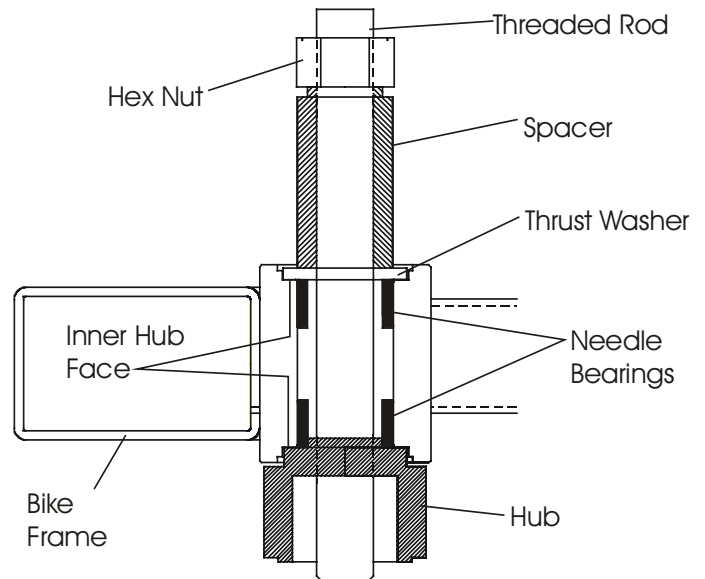

PRESSING IN NEW BEARINGS

13. Reassemble shaft and components. Use the exploded view below to aid in reassembly.
14. Reinstall the hubs. Refer to, How To...Remove Crank Shaft Hubs.
15. Reinstall the main drive belt. Refer to, How To...Remove Main Drive Belt.
16. Reinstall the side shrouds, crank arms, and pedals. Refer to, How To...in this section.

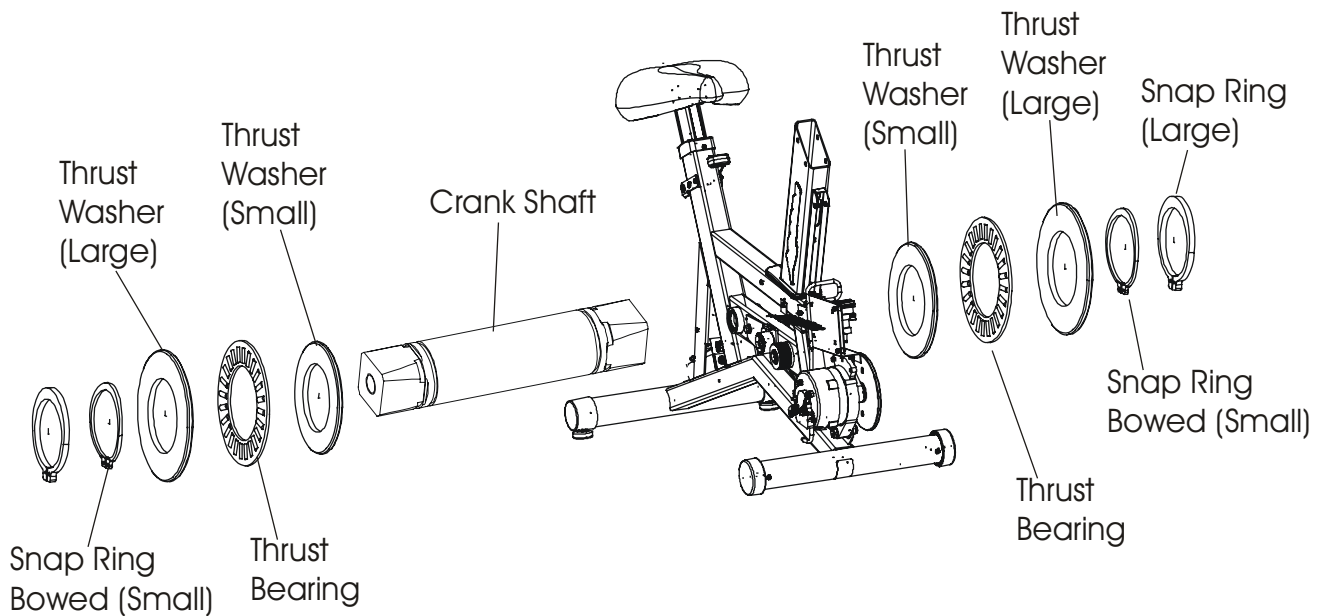

## Lifecycle Upright Bikes LC95, LC91, LC85, C9, C7, 95Ce, 95Ci, 93Ci, and 90C

### How To... Replace the Clutch Assembly

**Special Service Tools: NONE**

---

1. Remove the right side shrouds. Refer to, How To...Remove Pedals, Pedal Levers, and Side Covers.
2. Remove the main drive belt. Refer to, How To...Remove Main Drive Belt.
3. Remove the snap ring from the intermediate shaft.
4. Remove the washer, clutch assembly and washer from the shaft. Discard the clutch assembly.
5. Install the new clutch and its parts in reverse order. Make sure to install the step side into the frame.
6. Install main drive belt. Refer to, How To... Install Main Drive Belt.
7. Install shrouds and then pedals.

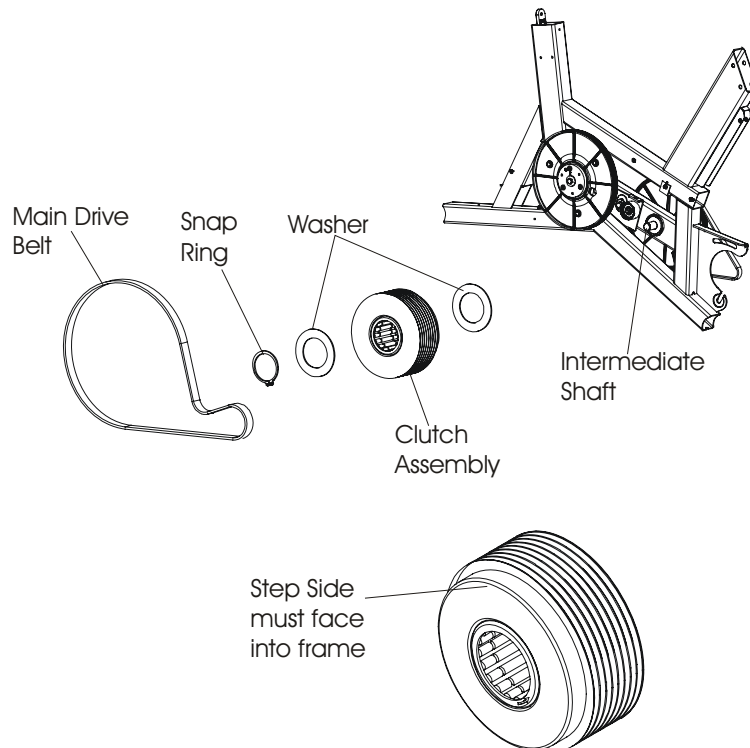

# Lifecycle Upright Bikes LC95, LC91, LC85, C9, C7, 95Ce, 95Ci, 93Ci, and 90C

## How To... Replace the Intermediate Pulley Shaft and Bearings

Special Service Tools: Bearing Service Tool Kit – Part Number: **BearingToolKit**

1. Remove the side covers. Refer to, How To...Remove Pedals, Pedal Levers, and Side Shrouds.

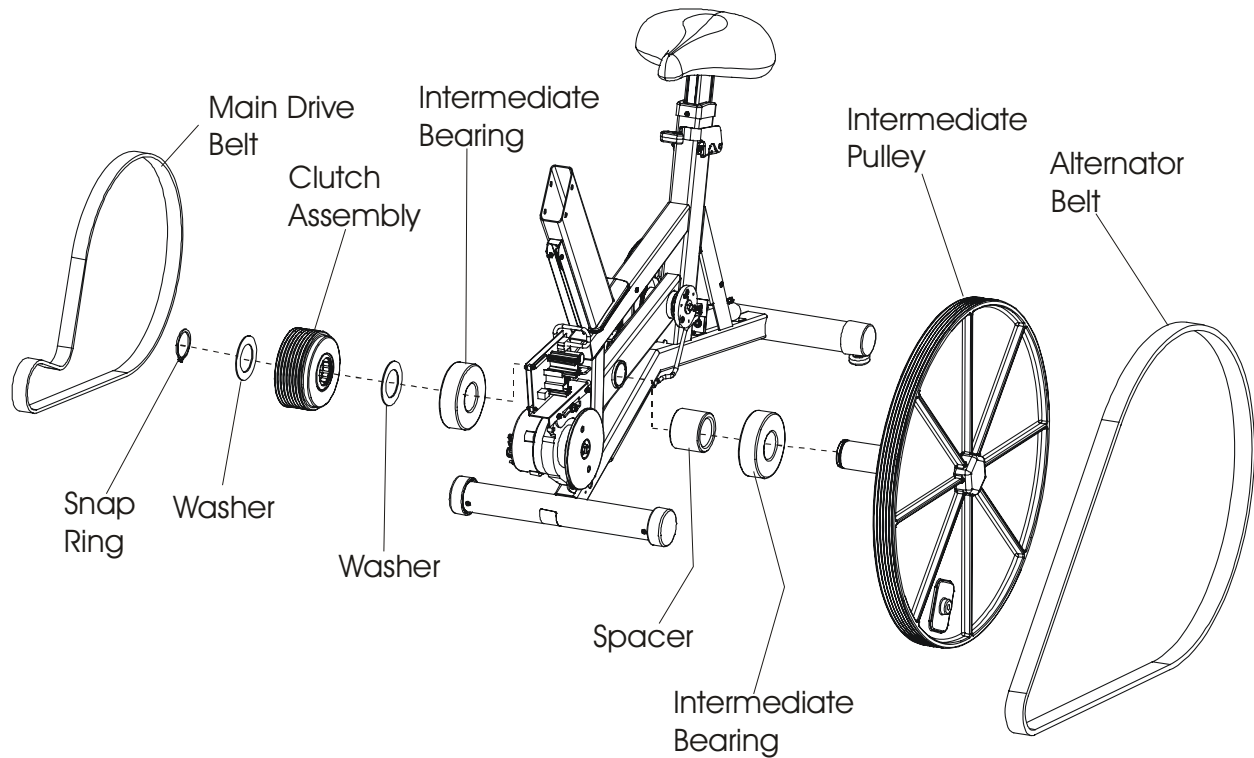

2. Remove the main drive belt. Refer to, How To...Remove Main Drive Belt.
3. Remove the clutch assembly. Refer to, How To...Remove the Clutch Assembly.
4. Remove the alternator belt. Refer to, How To...Remove the Alternator Belt.
5. Assemble 2-Jaw Puller, OTC Model 1025 to the bike frame at the intermediate pulley shaft as shown.

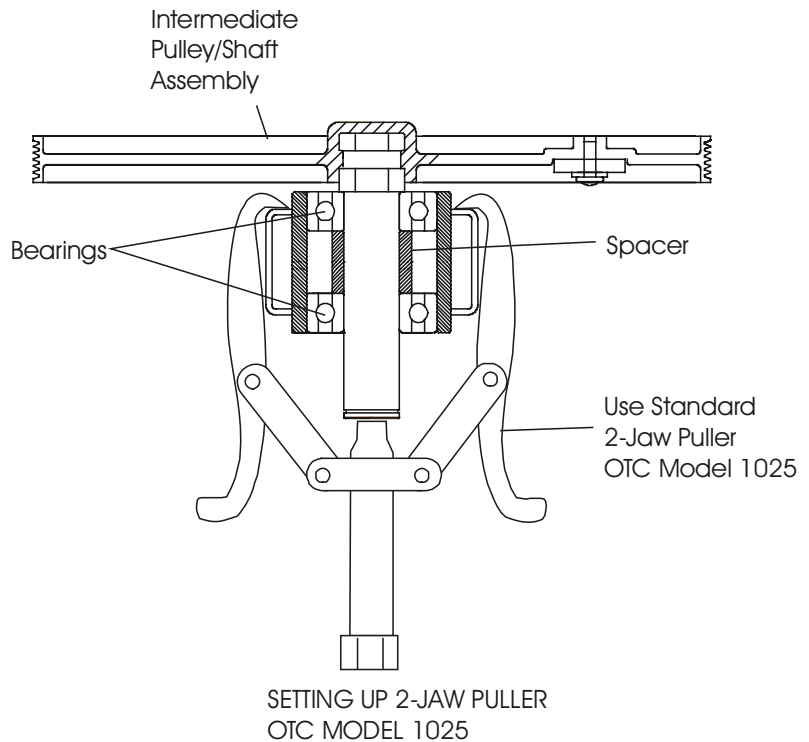

**Lifecycle Upright Bikes LC95, LC91, LC85, C9, C7, 95Ce, 95Ci, 93Ci, and 90C**  
**How To... Replace the Intermediate Pulley Shaft and Bearings - Continued**

**Special Service Tools: Bearing Service Tool Kit – Part Number: [BearingToolKit](#)**

6. Turn the forcing screw clockwise to press out the pulley shaft assembly from the bearings and spacer.
7. Once the pulley shaft is free of the bearings, proceed to remove the bearings.

Note: Do Not replace the pulley without replacing the bearings.

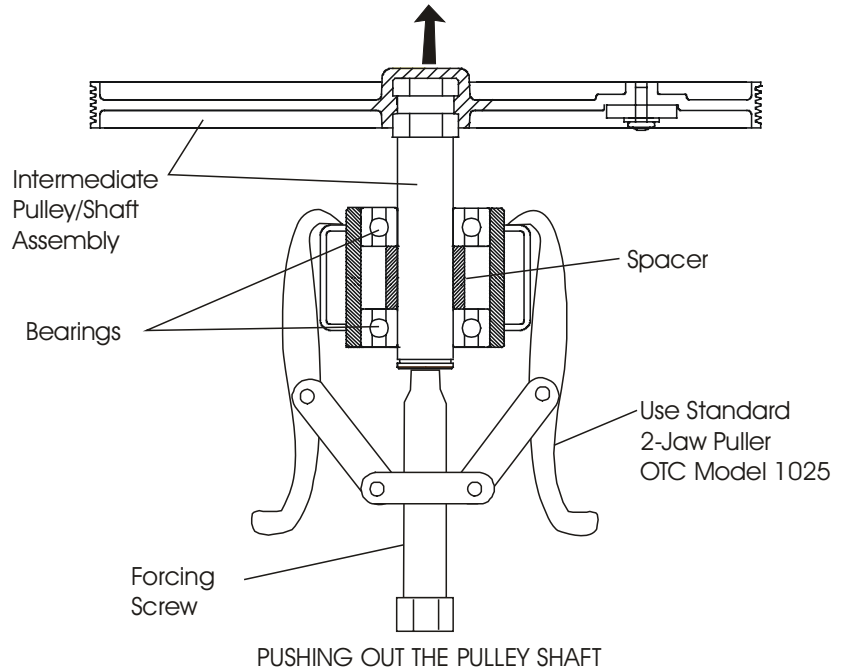

8. Install the bearing puller to the frame as illustrated.

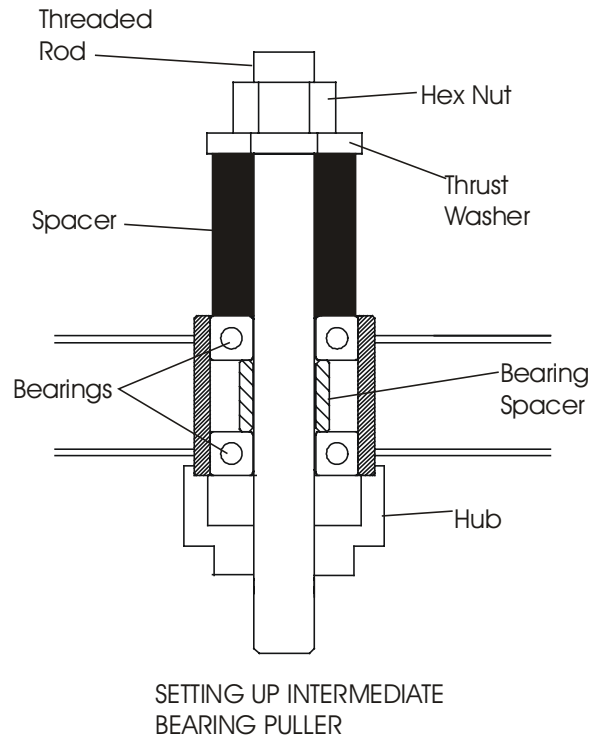

# Lifecycle Upright Bikes LC95, LC91, LC85, C9, C7, 95Ce, 95Ci, 93Ci, and 90C

## How To... Replace the Intermediate Pulley Shaft and Bearings - Continued

Special Service Tools: Bearing Service Tool Kit – Part Number: **BearingToolKit**

9. Turn the hex nut clockwise to push the 1<sup>st</sup> bearing out into the hub. Loosen puller assembly and remove the 1<sup>st</sup> bearing. At this time, remove the free floating spacer.
10. Retighten puller assembly and continue tightening until 2<sup>nd</sup> bearing is pressed out of its housing into the hub.
11. Remove the puller and discard the bearings.
12. Clean the housing.

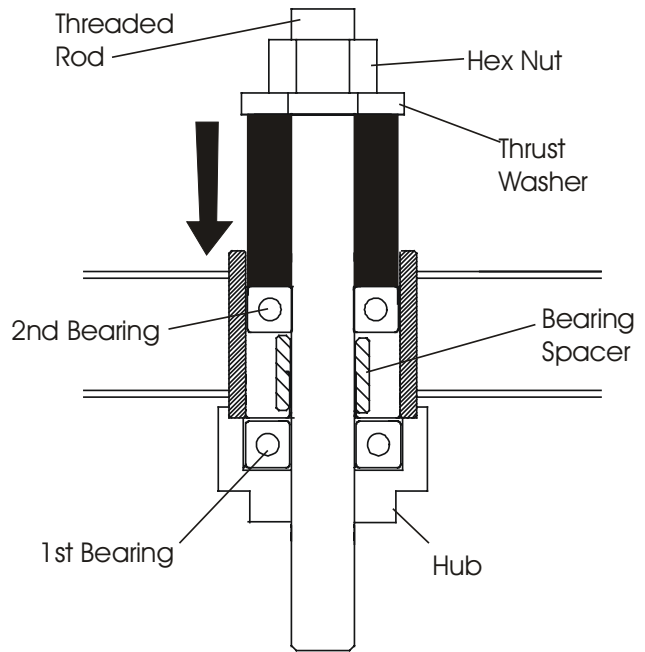

PUSHING OUT 1st BEARING

13. Install the bearing spacer back in the housing, and then position the bearings in the housing.
14. Install the puller assembly as shown. Make sure that the hub is reversed. Make sure all parts are aligned straight and square.

Note: When pressing in new bearings, it is important to understand that proper installation is critical to the life of the pulley shaft bearings, and that these bearings **MUST** be pressed firmly against the bearing spacer, which means that the bearing spacer **MUST** be held tightly in place (not loose). Step 16, on the next page describes a normal installation. However, should that not render the specified results, then proceed to Step 17. The difference being that Step 16 uses both thrust washers, whereas in Step 17 only one thrust washer is used.

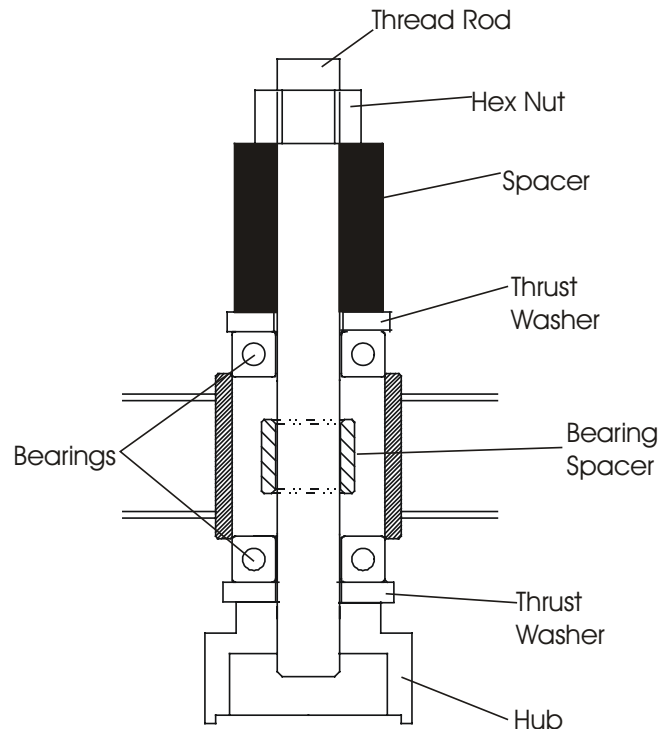

SETTING UP THE PULLER FOR PRESSING IN BEARINGS

# Lifecycle Upright Bikes LC95, LC91, LC85, C9, C7, 95Ce, 95Ci, 93Ci, and 90C

## How To... Replace the Intermediate Pulley Shaft and Bearings - Continued

Special Service Tools: Bearing Service Tool Kit – Part Number: **BearingToolKit**

15. Start tightening the hex nut to press in the bearings. Continue pressing in the bearings until the thrust washers(2) stop against the housing shoulder as shown.

16. Remove the puller assembly and check to see that the bearing spacer is securely held in position between the bearings. If the bearing spacer is secured between these bearings, then proceed to pressing in the intermediate shaft. If the bearing spacer is loose, then proceed to the next step.

17. If the bearing spacer is loose, then reinstall the puller assembly without the thrust washer on the side of the intermediate pulley (see illustration below). Continue pressing in the bearing, without holding or clamping the puller hub. When the bearing (next to the pulley) is properly seated against the bearing spacer, it will be slightly below flush and the puller hub will be free to spin. Proceed to press in the intermediate pulley/shaft.

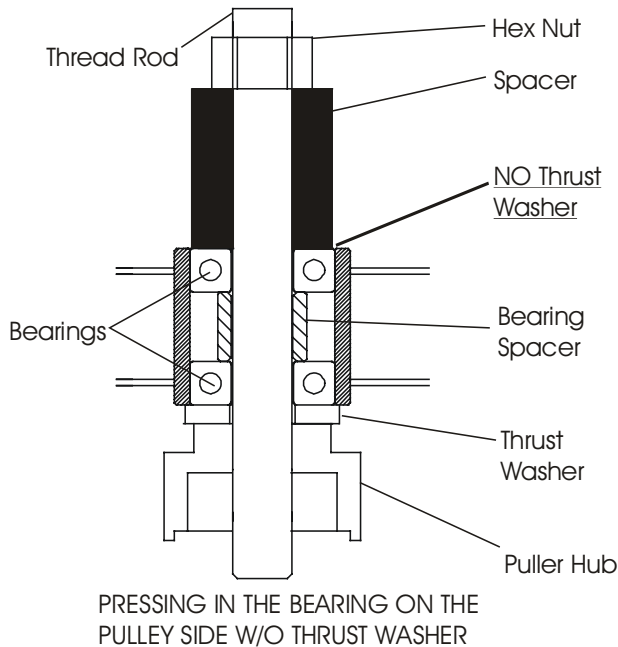
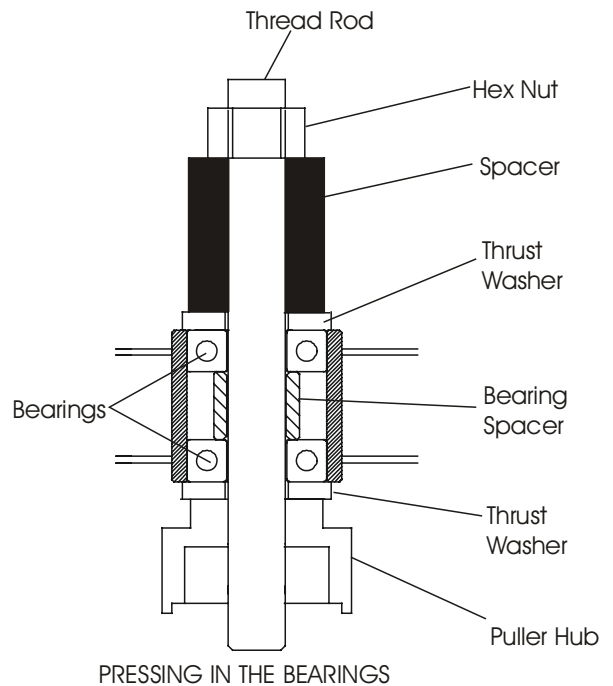

18. Position the intermediate pulley/shaft in the housing. Position the swivel spacer on top of the pulley and the stop block against the bottom bearing, then secure the C-clamp as illustrated. Make sure the shaft is aligned straight and square. Also make sure the plastic bearing spacer between the bearings is centered.

Note: Once the pulley/shaft gets started in the bearing, remove the C-Clamp to ensure the bearing spacer is in alignment to receive the shaft, then continue to press in the pulley/shaft.

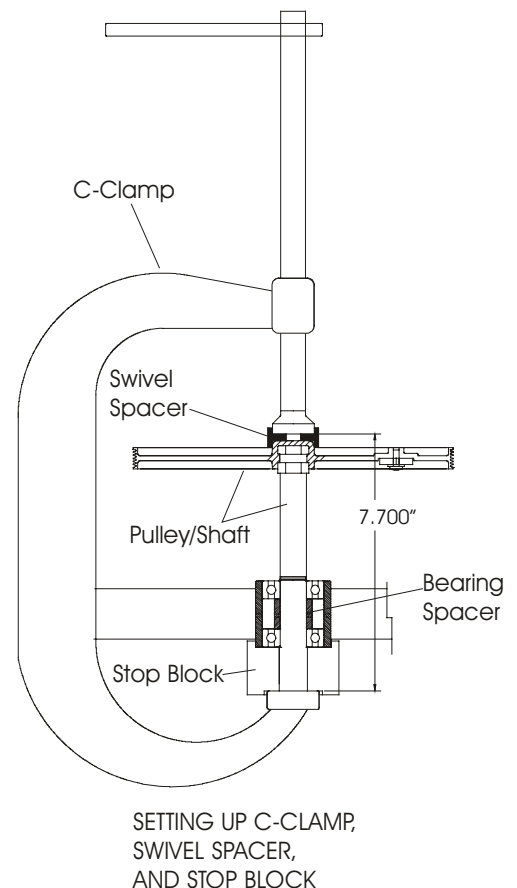

**Lifecycle Upright Bikes LC95, LC91, LC85, C9, C7, 95Ce, 95Ci, 93Ci, and 90C**  
**How To... Replace the Intermediate Pulley Shaft and Bearings - Continued**

**Special Service Tools: Bearing Service Tool Kit – Part Number: [BearingToolKit](#)**

---

19. Press in the pulley/shaft until the shaft bottoms against the 2<sup>nd</sup> bearing.

20. Remove the C-clamp and stop block.

21. Install the clutch assembly. Refer to, How To...Remove the Clutch Assembly.

22. Reinstall alternator belts. Refer to, How To in this section.

23. Install side shrouds and then the pedals.

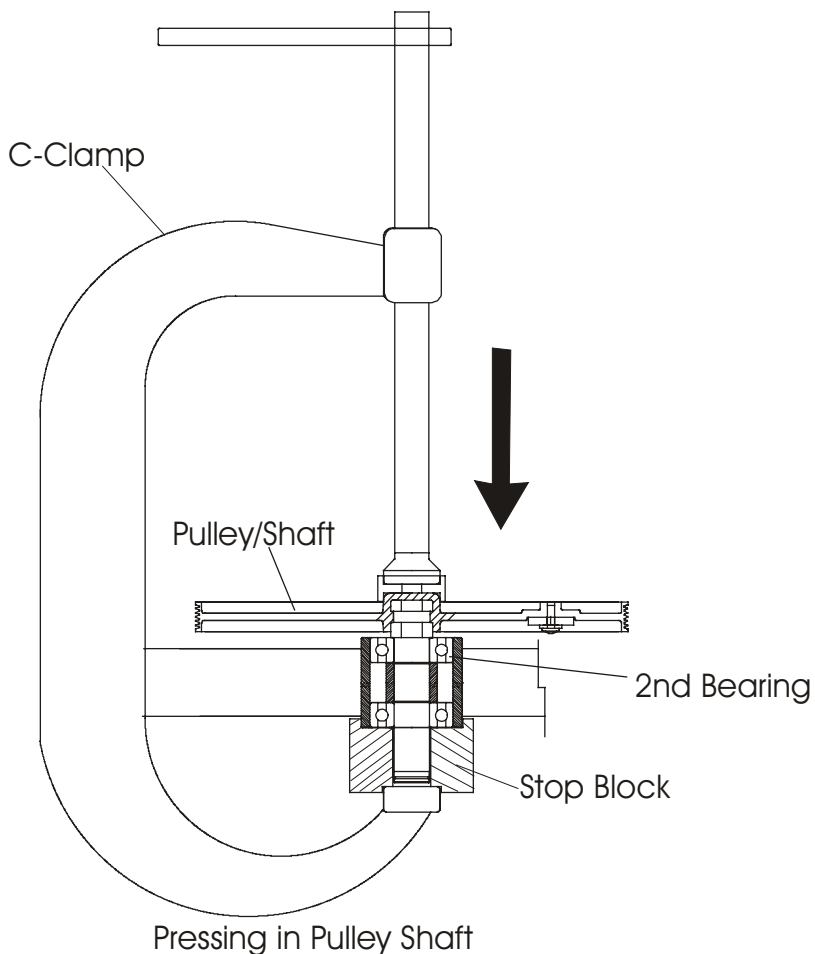

## Lifecycle Upright Bikes LC95, LC91, LC85, C9, C7, 95Ce, 95Ci, 93Ci, and 90C

### How To... Replace the Idler Roller

**Special Service Tools: NONE**

Note: The crank pulley and idler bracket are shown removed for clarity purposes only. Neither have to be removed to remove the idler roller.

1. Remove the right pedal, crank arm, and side shrouds. See "How To..." in this section.
2. Rotate the crank pulley until the rear mounting bolt on the idler bracket is visible.

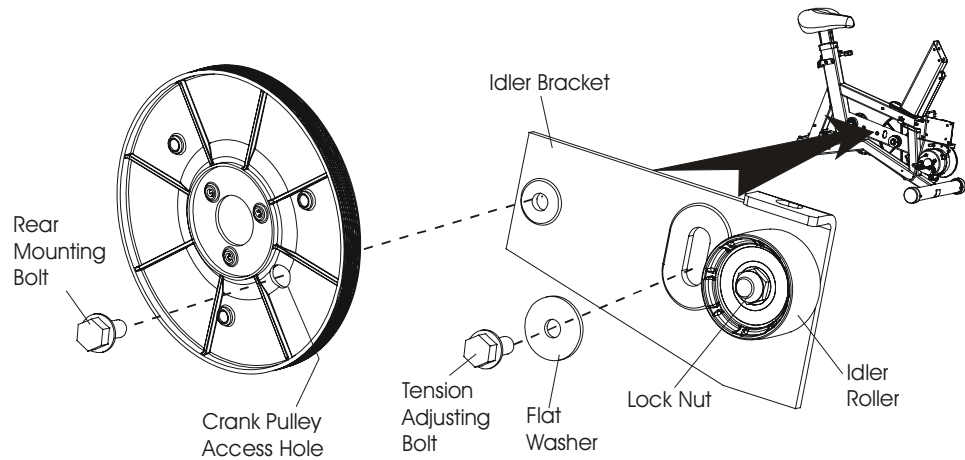

3. Loosen the rear mounting bolt through the access hole in the crank pulley
4. Loosen the tension adjusting bolt and washer on the bracket.
5. Remove the belt.
6. Remove the lock nut and remove the idler roller.
7. Install new idler roller in reverse order.
8. Adjust belt tension 100-110 lbs by moving the idler bracket down. Insert a straight blade screwdriver in the slotted lip of the bracket to obtain specified tension. When belt tension is achieved, then tighten the rear bolt and then the tensioning bolt in the bracket.



## Lifecycle Upright Bikes LC95, LC91, LC85, C9, C7, 95Ce, 95Ci, 93Ci, and 90C

### How To... Remove the Main Drive Belt

**Special Service Tools: NONE**

---

1. Remove the right pedal, right crank arm, and right shroud. See "How To..." in this section.
2. Rotate the crank shaft pulley until the access hole until the rear mounting bolt, on the idler bracket, is visible.
3. Loosen the rear mounting bolt on the idler bracket through the access hole in the crank arm pulley
4. Loosen the tension adjusting bolt at the front of the bracket.
5. Move the idler bracket assembly up to reduce belt tension.
6. Remove the main drive belt from the crank shaft pulley and the clutch assembly. Discard the main drive belt.
7. Snug the mounting bolts on the idler bracket to allow for belt tensioning.
8. Install a new main drive belt on the crank shaft pulley and the clutch assembly.
9. Move the idler bracket down to increase belt tension. Adjust the belt tension 100-110 lbs. When belt tension is achieved, then tighten the bracket bolts.

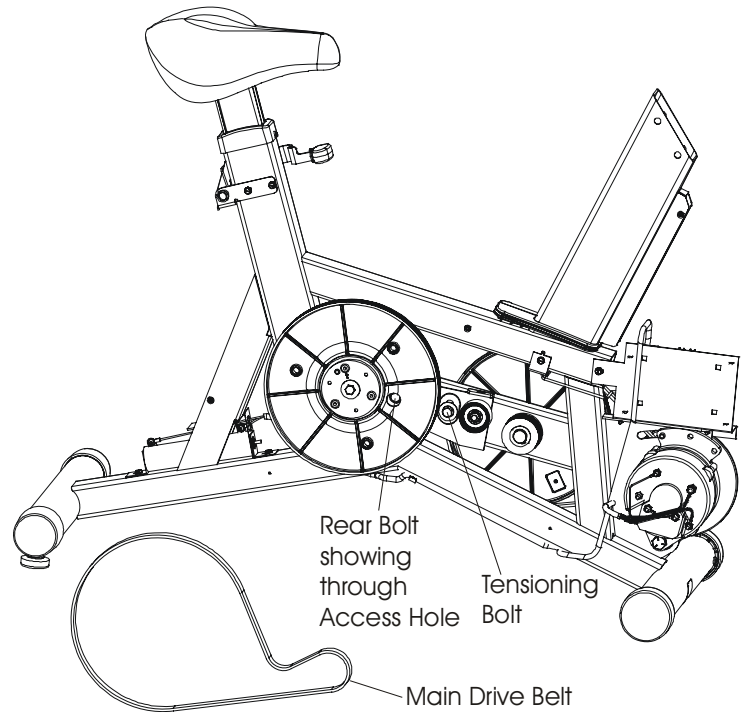

## Lifecycle Upright Bikes LC95, LC91, LC85, C9, C7, 95Ce, 95Ci, 93Ci, and 90C

### How To... Remove the Alternator

Special Service Tools: Belt Tensioning Gauge

---

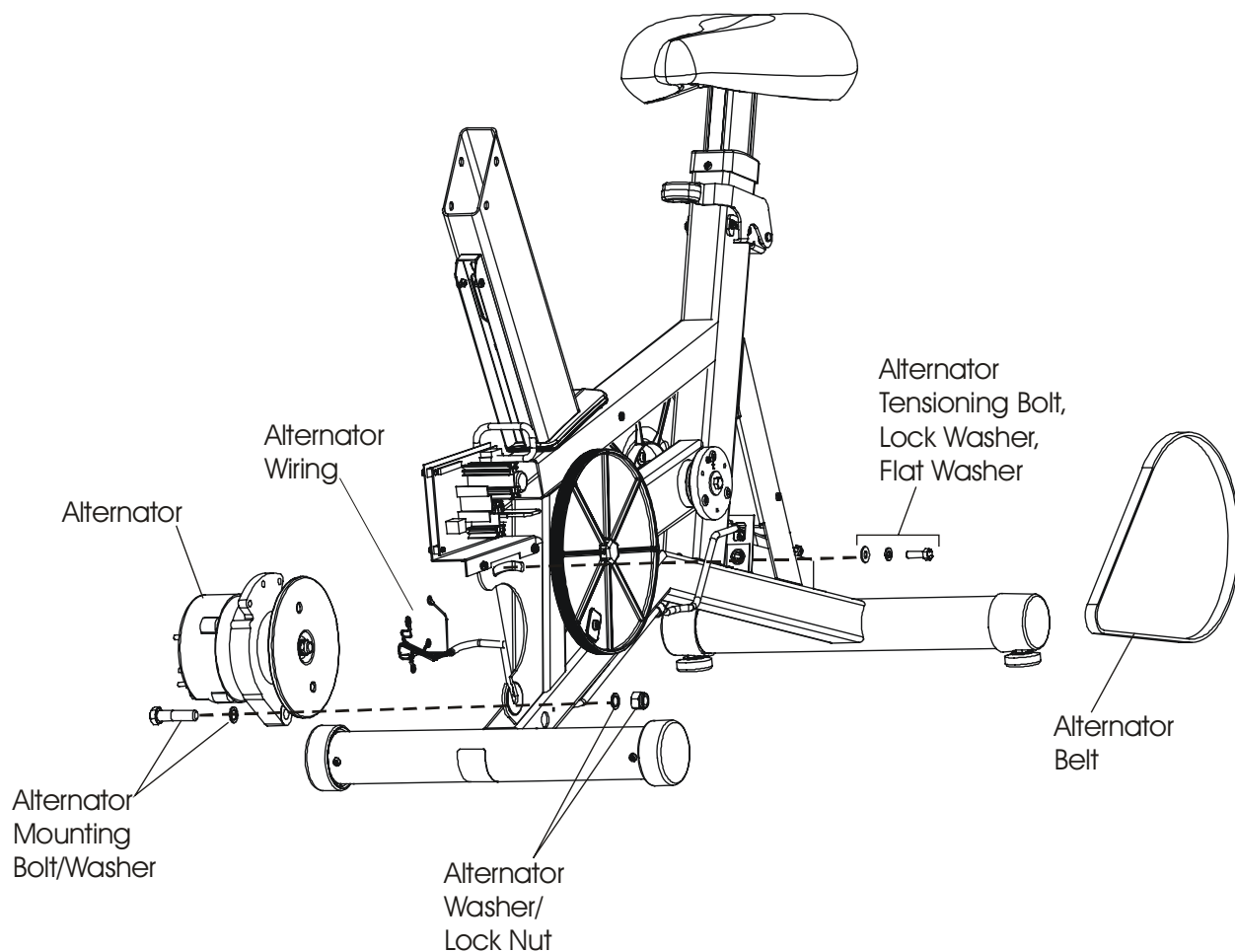

1. Remove the pedals, crank arms, and side shrouds. See "How To..." in this section.
2. Remove alternator wiring from alternator. Note the location of each wire.
3. Remove the alternator tensioning bolt.
4. Loosen the alternator mounting bolt, and then pivot the alternator enough to slacken the alternator belt, then remove the alternator belt.
5. Remove the alternator mounting bolt, washers, and lock nut, and lift the alternator off the frame.
6. Install new alternator in reverse order.
7. Position new alternator belt on the far left groove of the alternator pulley (user's side) and not in the center of the pulley. Tighten the alternator belt 70-80 lbs.

## Lifecycle Upright Bikes LC95, LC91, LC85, C9, C7, 95Ce, 95Ci, 93Ci, and 90C

### How To... Remove the Alternator Belt

#### Special Service Tools: Belt Tensioning Gauge

---

1. Remove the pedals, crank arms, and side shrouds. See "How To..." in this section.
2. Loosen the alternator tensioning bolt.
3. Loosen the alternator mounting bolt, and then pivot the alternator enough to slacken the alternator belt.

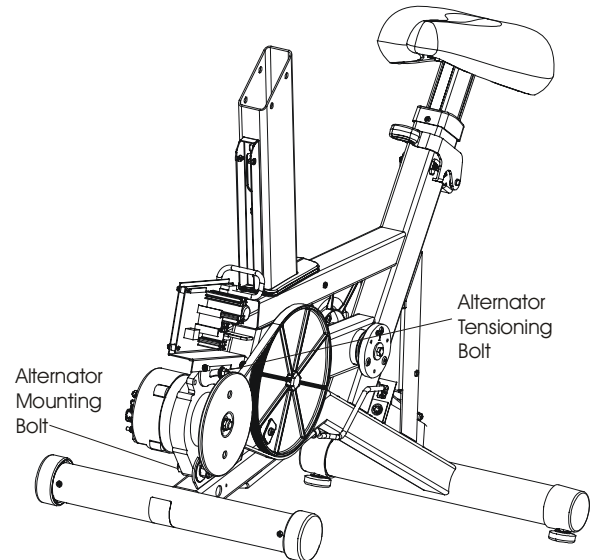

4. Remove the alternator belt.
5. Position new alternator belt on the far left groove of the alternator pulley (user's side) and not in the center of the pulley. Tighten the alternator belt 70-80 lbs.

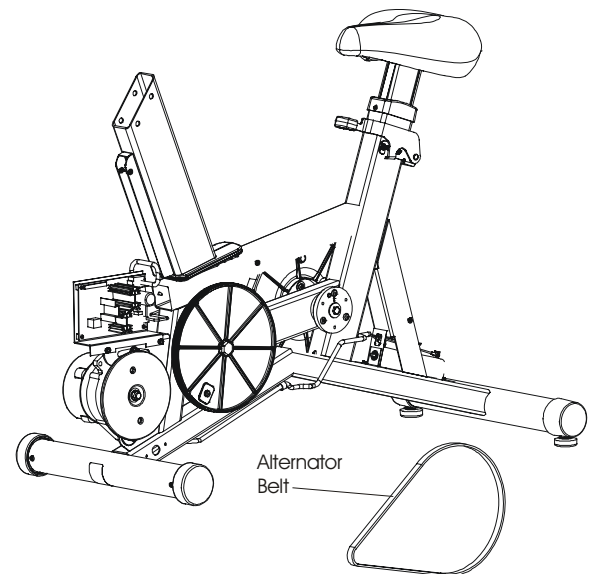

# Lifecycle Upright Bikes LC95, LC91, LC85, C9, C7, 95Ce, 95Ci, 93Ci, and 90C

## How To... Remove the Seat Post Assembly (Latch LC8500, 9100, 9500)

**Special Service Tools: NONE**

---

1. Remove the side shrouds. Refer to, How To...in this section.
2. Remove two screws on the seat post collar.
3. Remove four mounting screws securing the latch assembly to the frame. If disassembly is required, refer to the procedure below.
4. Lift out the seat post assembly with seat attached.
5. Remove four mounting screws securing the seat to the seat post.
6. Service the seat post assembly as required.
7. Reinstall the seat and seat post in reverse order.
8. Reassemble the latch assembly and secure to frame with four mounting screws.

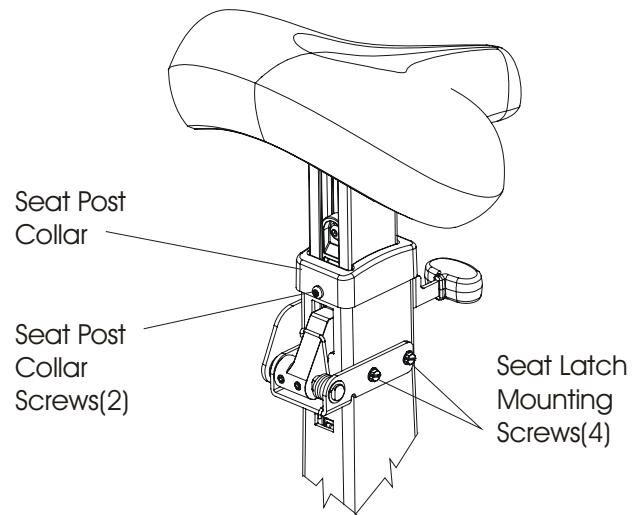

### Release Latch Disassembly

1. Remove the two set screws from the latch rack.
2. Slide the handle-shaft out from the latch bracket, latch rack, and spring. Catch the latch rack and spring as shaft is removed.
3. Remove the two NYLINER from the sides of the latch bracket.
4. If necessary, the E-Ring can be removed from the shaft for replacement.
5. When reinstalling parts, make sure that the latch rack is seated up against the shaft STOP, and then tighten the latch rack set screws.
6. Reinstall latch assembly back on the seat post.

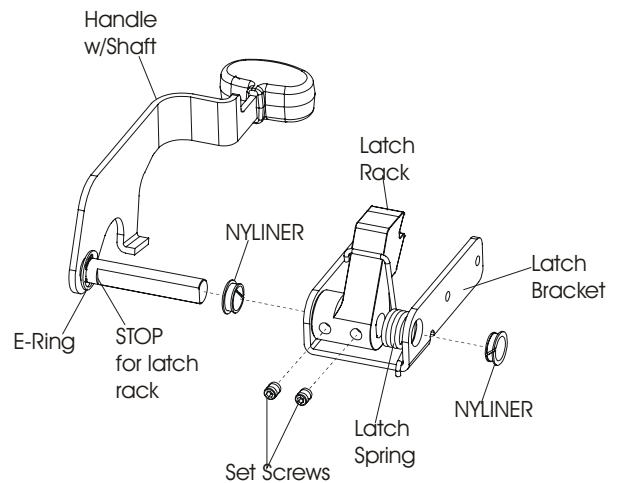

## Lifecycle Upright Bikes LC95, LC91, LC85, C9, C7, 95Ce, 95Ci, 93Ci, and 90C How To... Remove the Seat Post Assembly (Pull-Pin C7 and C9)

**Special Service Tools: NONE**

---

1. Remove the side shrouds. Refer to, How To...in this section.
2. Remove the seat post collar screws(2).
3. Compress the internal snap ring in front of the pull-pin knob and pull out the pull-pin assembly.
4. Lift out the seat post assembly with seat, from the frame.
5. Remove four screws securing the seat to the seat post.
6. Service the seat post as required.
7. Reinstall seat post in reverse order and reattach seat.

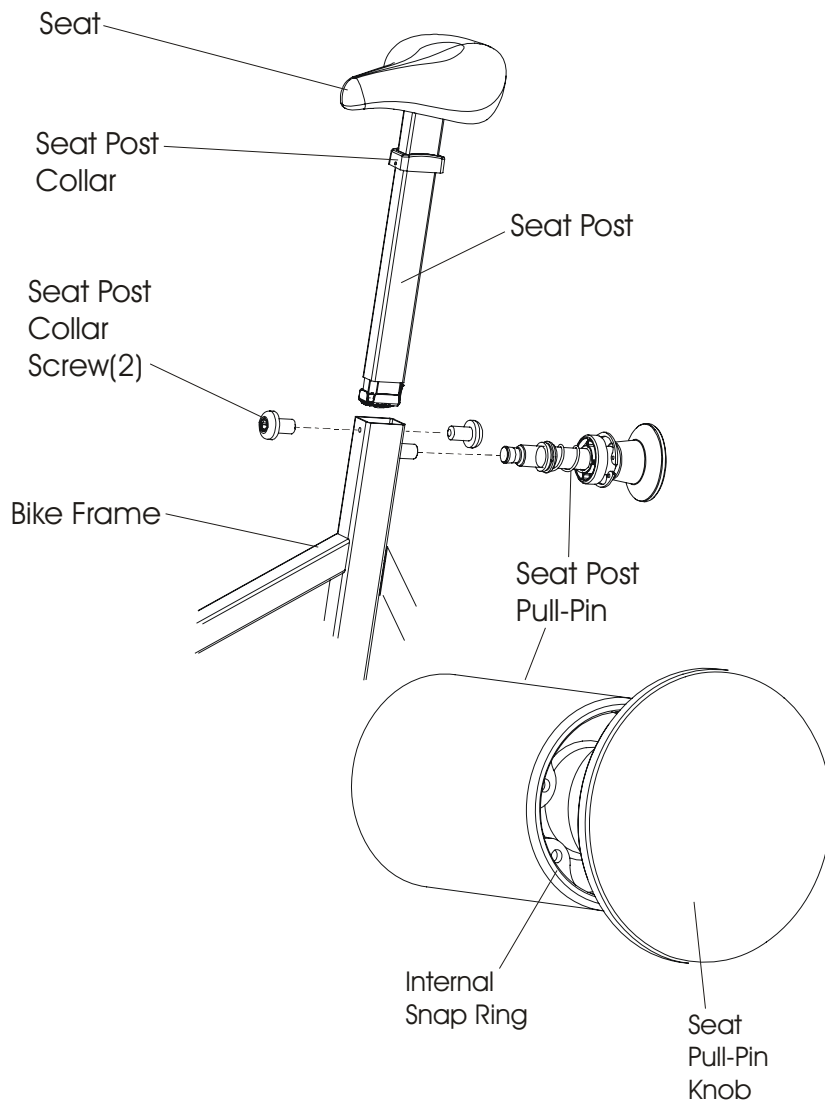

## Lifecycle Upright Bikes LC95, LC91, LC85, C9, C7, 95Ce, 95Ci, 93Ci, and 90C

### How To... Remove the Main Wiring Harness

**Special Service Tools: NONE**

---

1. Remove the side shrouds. Refer to, How To... in this section.
2. Remove the handlebar. Refer to, How To... in this section.
3. Disconnect the main wiring harness at the power control board.
4. Disconnect the main wiring harness from the cable ties along the frame.
5. Route the cable out of the console post assembly.
6. Install new main wiring harness in reverse order.

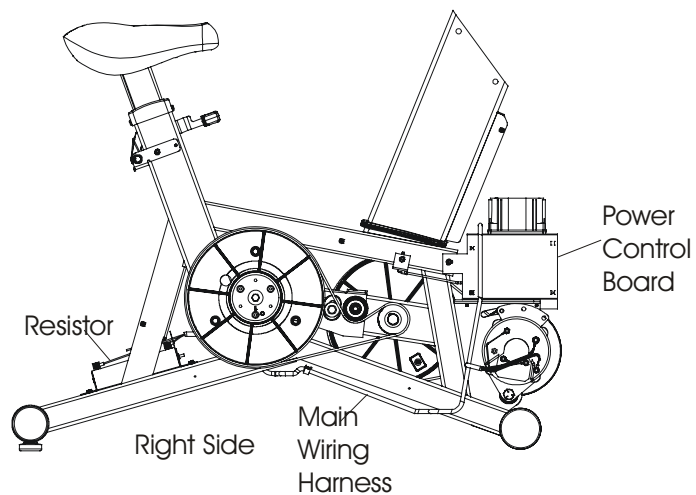
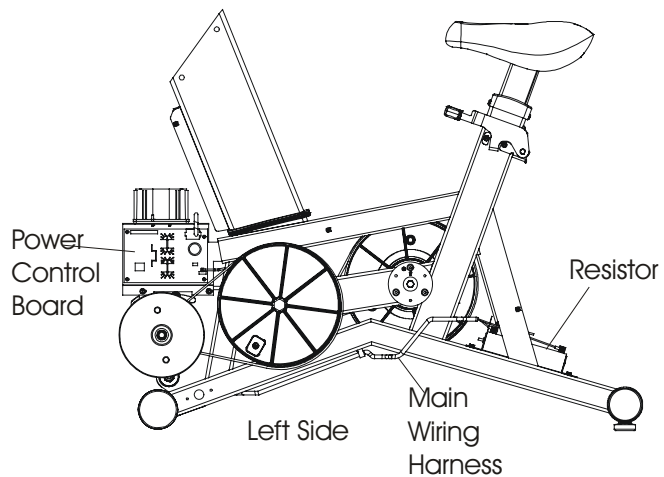

## **Lifecycle Upright Bikes LC95, LC91, LC85, C9, C7, 95Ce, 95Ci, 93Ci, and 90C**

### **How To... Remove the 9-Volt Console Battery (LC8500 and C7)**

**Special Service Tools: NONE**

---

**NOTE: The 9 Volt console battery is located back of the console.**

1. Remove the cover at the back of the console assembly to reveal the battery.

**NOTE: Console removed for clarity.**

2. Remove the battery and replace with new one.
3. Reinstall the battery cover.

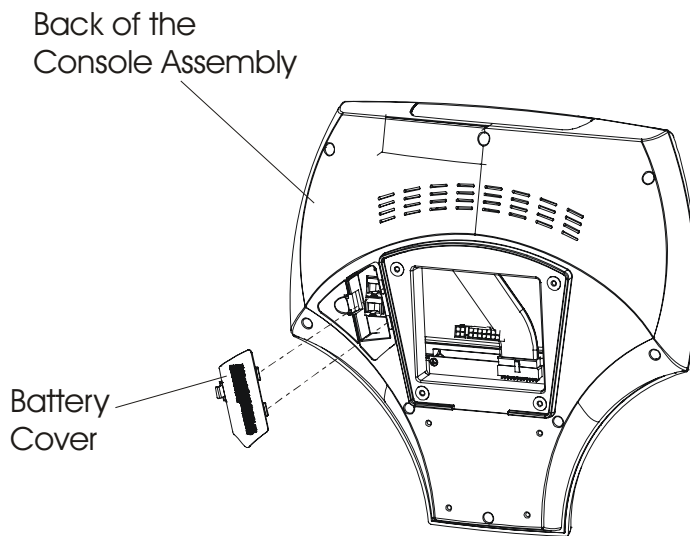

## Lifecycle Upright Bikes LC95, LC91, LC85, C9, C7, 95Ce, 95Ci, 93Ci, and 90C How To... Remove the 6-Volt Battery (LC9500, 9100 and C9)

Special Service Tools: NONE

---

1. Remove the side shrouds. Refer to, How To...in this section.
2. Disconnect the wires from the battery terminals.
3. Remove the battery mounting screws(2) and battery harness clip.
4. Remove the battery and discard.
5. Install new battery in reverse order.

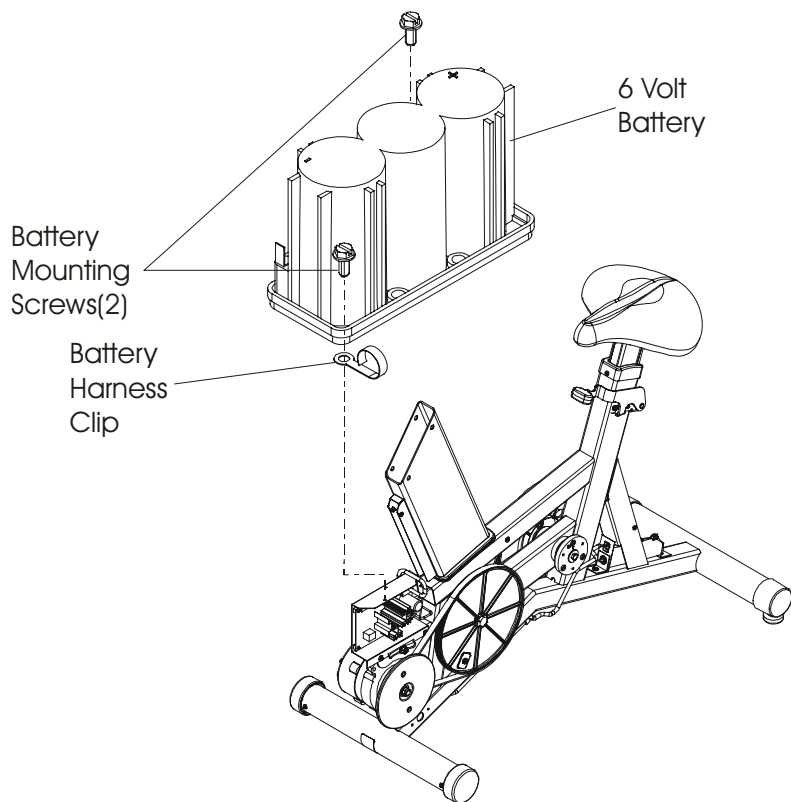



## Lifecycle Upright Bikes LC95, LC91, LC85, C9, C7, 95Ce, 95Ci, 93Ci, and 90C How To... Remove the Display Console and Accessory Tray

Special Service Tools: NONE

---

1. Remove four mounting screws from the back of the console at the console support.
2. Lift the console up just enough to disconnect the main wiring, and then remove the console and the accessory tray.
3. Remove four mounting screws from under the accessory tray which mounts to the underside of the console.

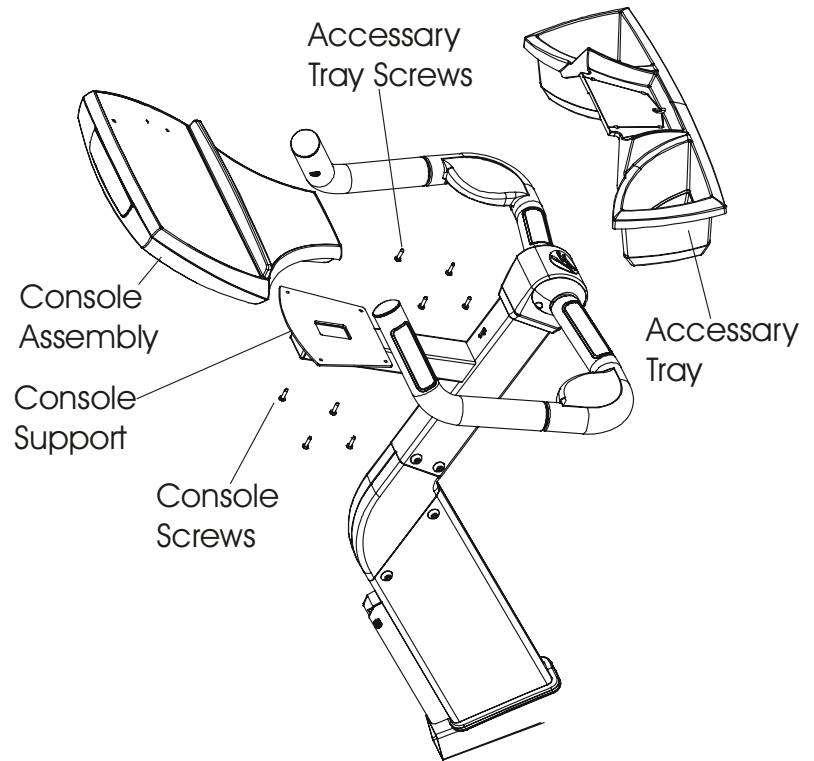

**Lifecycle Upright Bikes LC95, LC91, LC85, C9, C7, 95Ce, 95Ci, 93Ci, and 90C**  
**How To... Remove the Console Post Assembly, Main cable and Coax (on LCD only)**

**Special Service Tools: NONE**

---

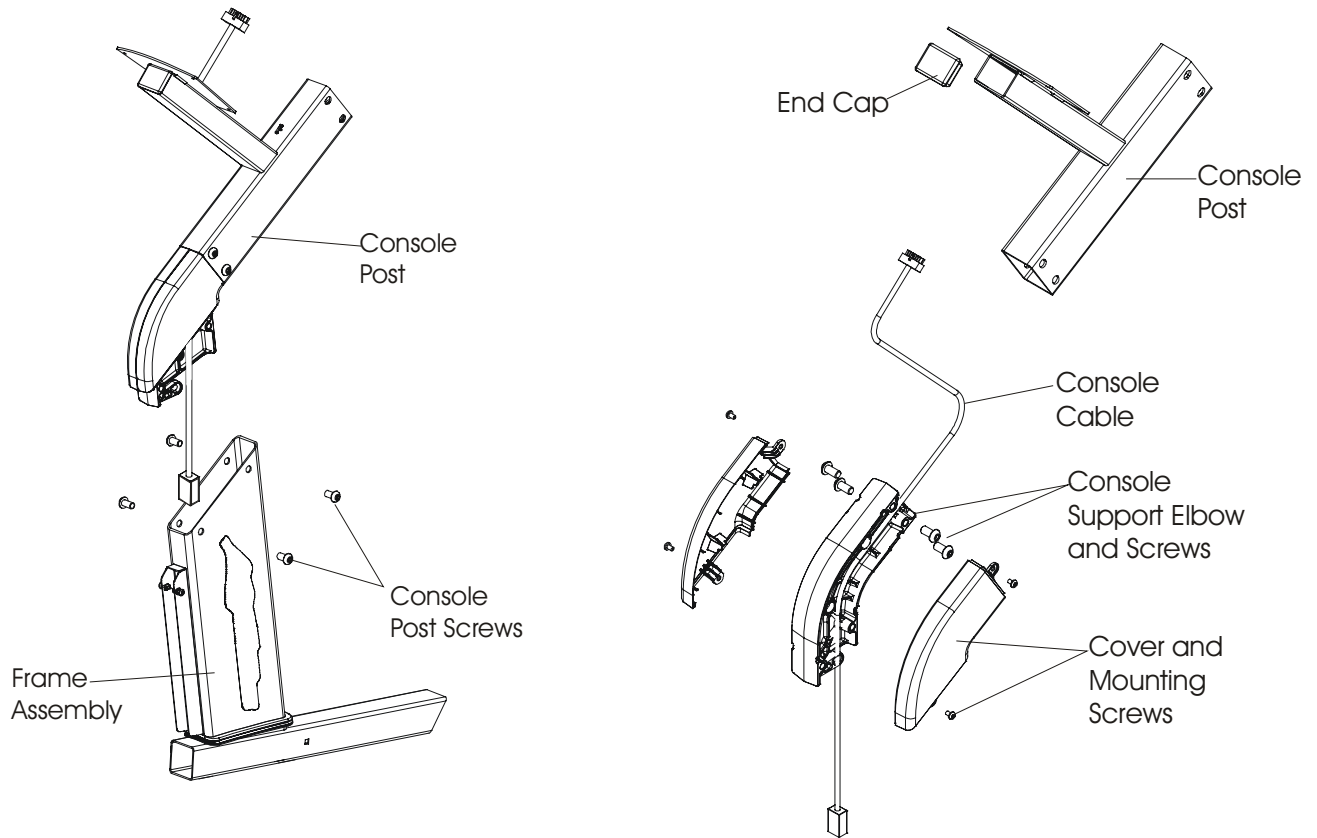

1. Remove the handle bars. Refer to, How To... in this section.
2. Remove the console and if equipped, the accessory tray. Refer to, How To...in this section.
3. Remove the left side shroud. See How To...Remove Shrouds.
4. Unplug the main console cable from the power control board (large connector).
5. Remove four mounting screws securing the console support elbow to the frame, and lift the console post and elbow out of the frame.
6. Remove the side covers from the support elbow and discard the console post.
7. Replace the console post in the reverse order of removal.

## Lifecycle Upright Bikes LC95, LC91, LC85, C9, C7, 95Ce, 95Ci, 93Ci, and 90C How To... Remove the Power Control Board (LC8500 and C7)

Special Service Tools: NONE

---

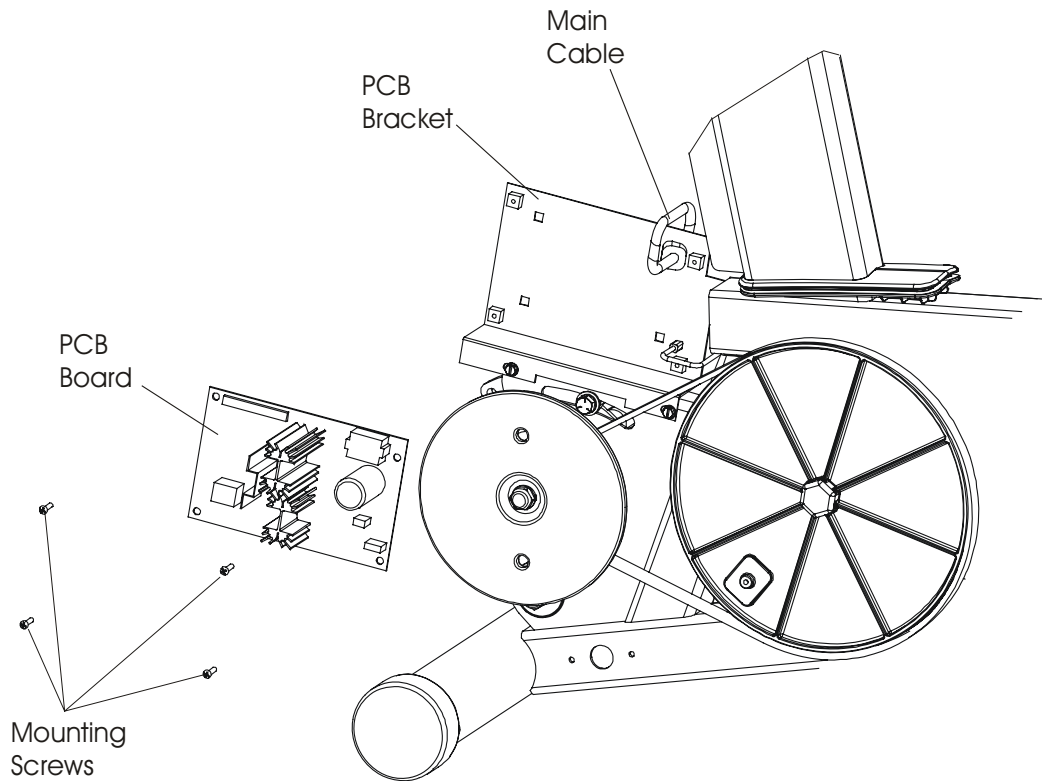

1. Remove the left pedal and crankarm, and then remove the left side shroud.
2. Disconnect the two cables to the PCB.
3. Remove four screws securing the PCB to the bracket.
4. Install new PCB board in reverse order.

**Lifecycle Upright Bikes LC95, LC91, LC85, C9, C7, 95Ce, 95Ci, 93Ci, and 90C**  
**How To... Remove the Power Control Board (LC9500, 9100 and C9)**

Special Service Tools: NONE

---

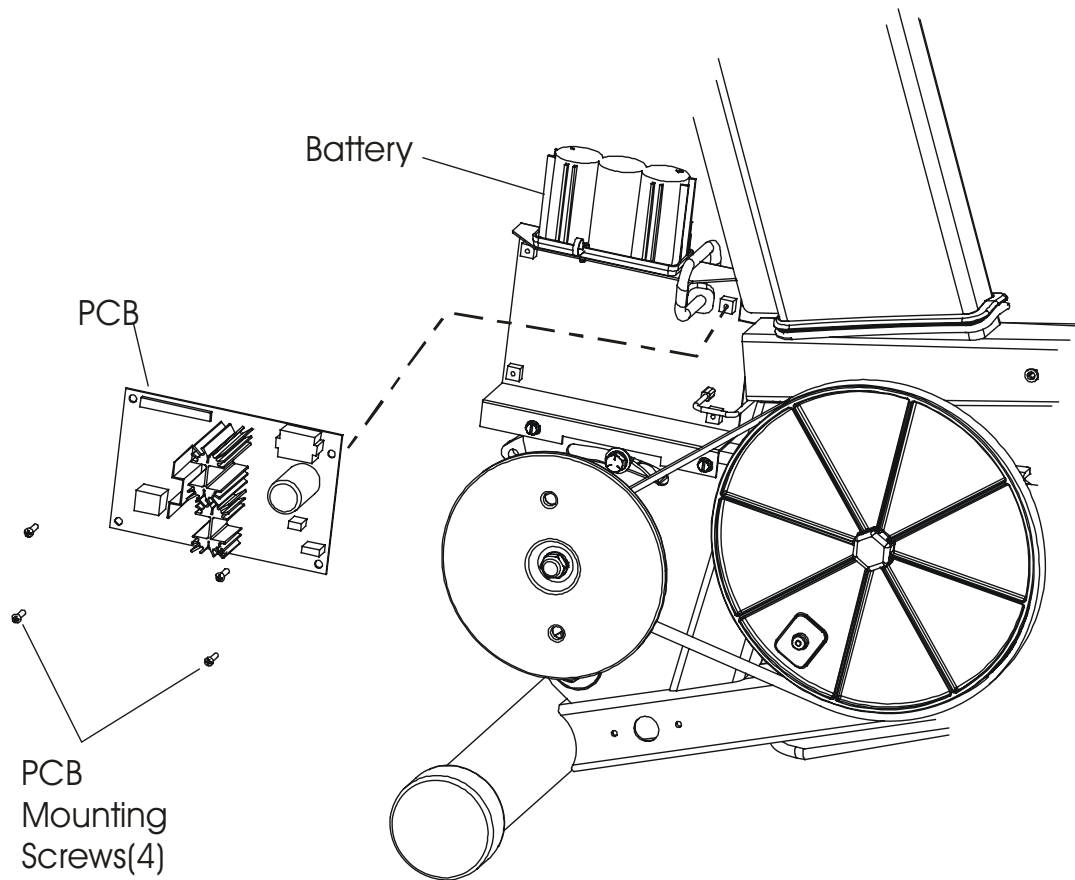

1. Remove the left pedal and crankarm, and then remove the left side shroud.
2. Disconnect the two cables to the PCB.
3. Remove four screws securing the PCB to the bracket.
4. Install new PCB board in reverse order.

## Lifecycle Upright Bikes LC95, LC91, LC85, C9, C7, 95Ce, 95Ci, 93Ci, and 90C

### How To... Remove the Pedal

Special Service Tools: NONE

---

1. Remove the right pedal using an open end wrench and loosening the pedal shaft by rotating it counterclockwise.
2. Remove the left pedal using an open end wrench and loosening the pedal shaft by rotating it clockwise.
3. Install the right pedal using an open end wrench and tighten the pedal shaft into the crankarm by rotating it clockwise.
4. Install the left pedal using an open end wrench and tighten the pedal shaft into the crankarm by rotating it counterclockwise.

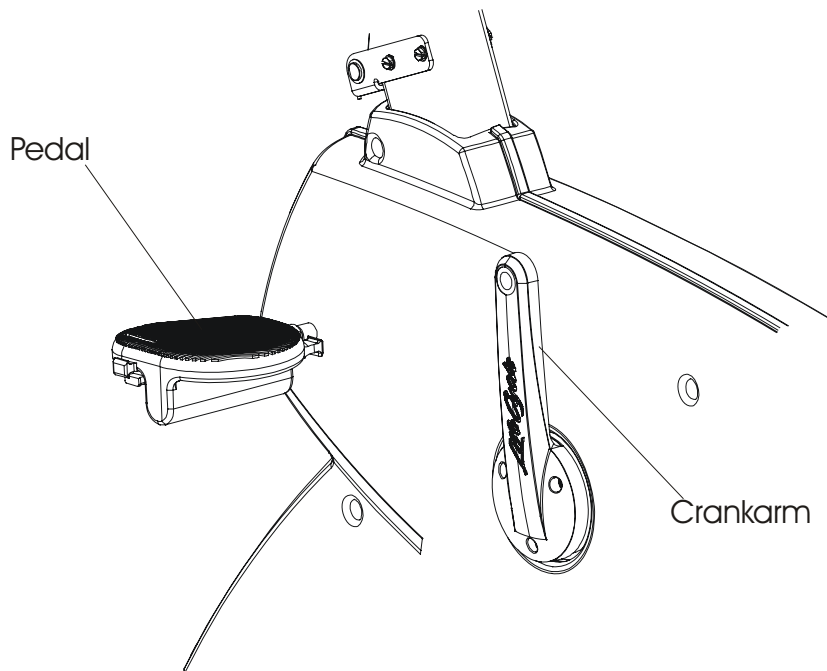

## Lifecycle Upright Bikes LC95, LC91, LC85, C9, C7, 95Ce, 95Ci, 93Ci, and 90C

### How To... Remove the Front Wheels

Special Service Tools: NONE

---

1. Remove the two wheel insert screws from each side of the front stabilizer.
2. Pull out the wheel bearing and wheel insert together. The wheel and insert are held together by a screw and washer.
3. Install new front wheel assembly in the reverse order.

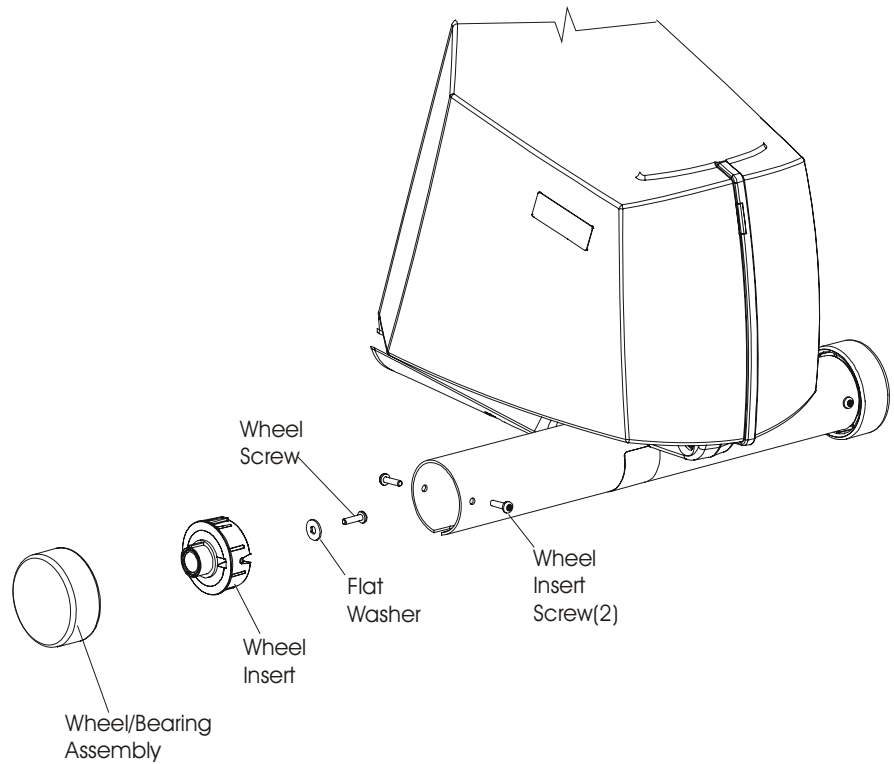

## Lifecycle Upright Bikes LC95, LC91, LC85, C9, C7, 95Ce, 95Ci, 93Ci, and 90C

### How To... Remove the Handlebar Assembly

Special Service Tools: NONE

---

1. Remove four screws securing the top half of the sensor cover.
2. Remove four mounting screws securing the handle bar to the post.
3. Lift out the handlebar just enough to disconnect heart rate sensor wiring.

Note: C7, LC8500, and LC9100 have no heart rate sensors.

4. Remove the handlebar.
5. Install the handle bar in reverse order.

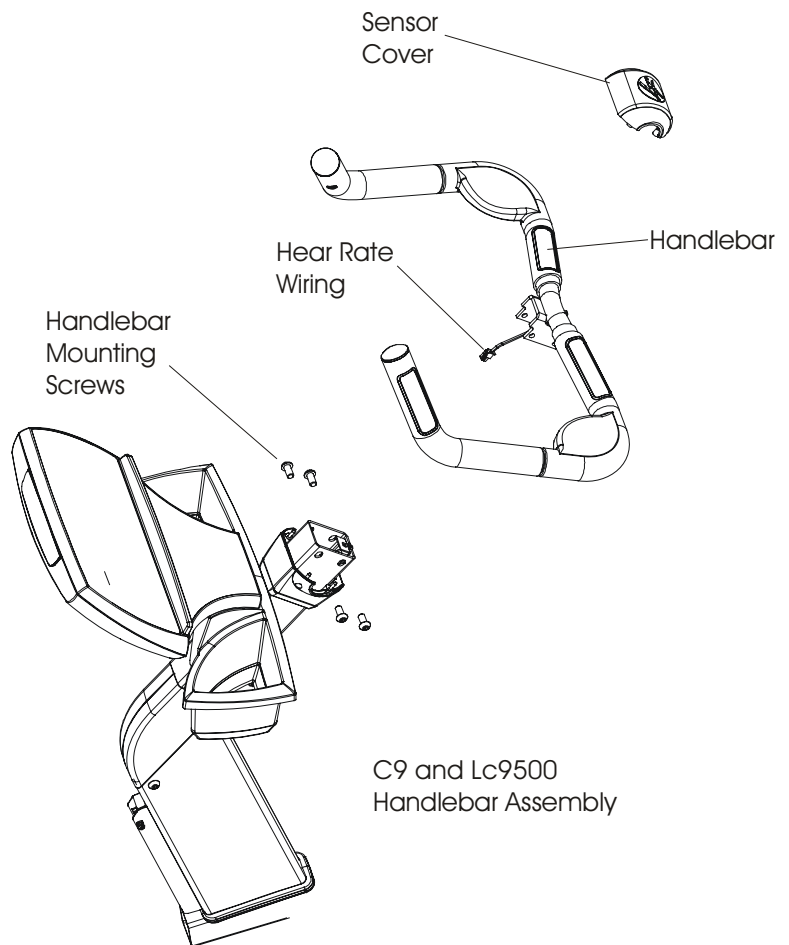

## **Lifecycle Upright Bikes LC95, LC91, LC85, C9, C7, 95Ce, 95Ci, 93Ci, and 90C How To... Remove the Heart Rate Sensor (LC9500 and C9)**

**Special Service Tools: NONE**

---

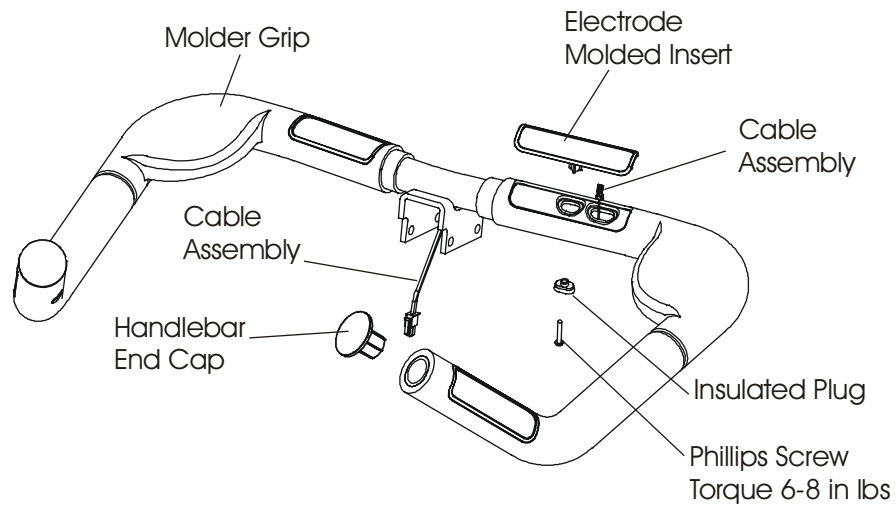

1. Remove the Phillips screw securing the molded insert to the handlebar.
2. Lift the molded insert enough to disconnect the cable.
3. Before pulling out the cable, attach a 3 ft piece of string at one end of the old cable, and then pull the other end of the cable out until the string appears. Detach the string and discard the cable
4. Attach new cable to string. Pull the string to fish out the cable through the handle bar.
5. Reinstall new electrode molded insert in reverse order.



# Lifecycle Upright Bikes LC95, LC91, LC85, C9, C7, 95Ce, 95Ci, 93Ci, and 90C

## How To... Remove the Telemetry Receiver and Telemetry Receiver Cable (LC9500, 9100, 8500, and C7)

Special Service Tools: NONE

---

### Telemetry Receiver

1. Remove four screws securing the top sensor cover.
2. Unplug the telemetry sensor from its connector.
3. Install new telemetry sensor in reverse order.

### Telemetry Receiver Cable

Note: The telemetry cable is connected to a connector mounted in a bracket. This bracket is mounted to the inside of the console post, under the sensor cover. The other end of the cable is connected into the back of the console display board. Proceed with the following steps to properly replace this cable.

1. Remove the telemetry sensor as indicated above.
2. Remove the console display. See How To...Remove Display Console and Accessory Tray.
3. Raise the console display just enough to access the telemetry cable connector and disconnect it from the back of the console board. Now tie a 3 ft piece of string around the end of this connector. This will act as a fish line for pulling in the new cable.
4. Lower the bottom sensor cover on the console post to access the bracket screws. Remove two screws in the back of console post, which secures the bracket which is located inside the console post where the telemetry connector mounts and telemetry sensor plugs-in.

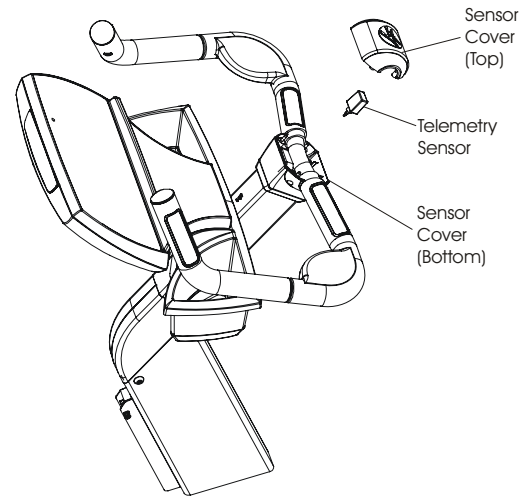

5. Pull out the bracket with attached telemetry connector and cable from the console post just enough to disconnect the telemetry cable leads from the connector on the bracket
6. Now gently pull out the telemetry cable until the string appears. Remove the string from the old cable and attach it around the new telemetry cable.
7. Before fishing the new cable through the console post, reconnect the telemetry cable leads back into the connector on the bracket. Now start pulling on the string until the new telemetry cable appears through the console post. Reconnect the connector at the other end of the cable to the back of the console board.

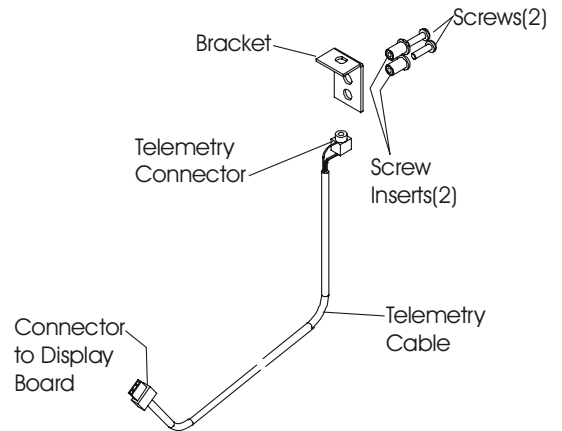

8. Reattach the console display back on the console post.
9. Now go back and secure the bracket inside the console post with the two screws.
10. Plug-in the telemetry sensor back into its connector.
11. Secure the top cover to the bottom cover.

## Lifecycle Upright Bikes LC95, LC91, LC85, C9, C7, 95Ce, 95Ci, 93Ci, and 90C

### How To... Remove the Resistor Assembly

Special Service Tools: NONE

**CAUTION! BEFORE REPLACING CIRCUIT BOARD(S), GROUND YOURSELF TO EARTH GROUND USING AN ANTI-STATIC GROUND STRAP.**

1. Remove the side shrouds. Refer to, How To... in this section.
2. Remove two cable mounting screws and nuts securing the cable to the terminals.
3. Remove mounting screws securing the resistor to the frame, and then lift out the resistor assembly.
4. Install new resistor in reverse order.

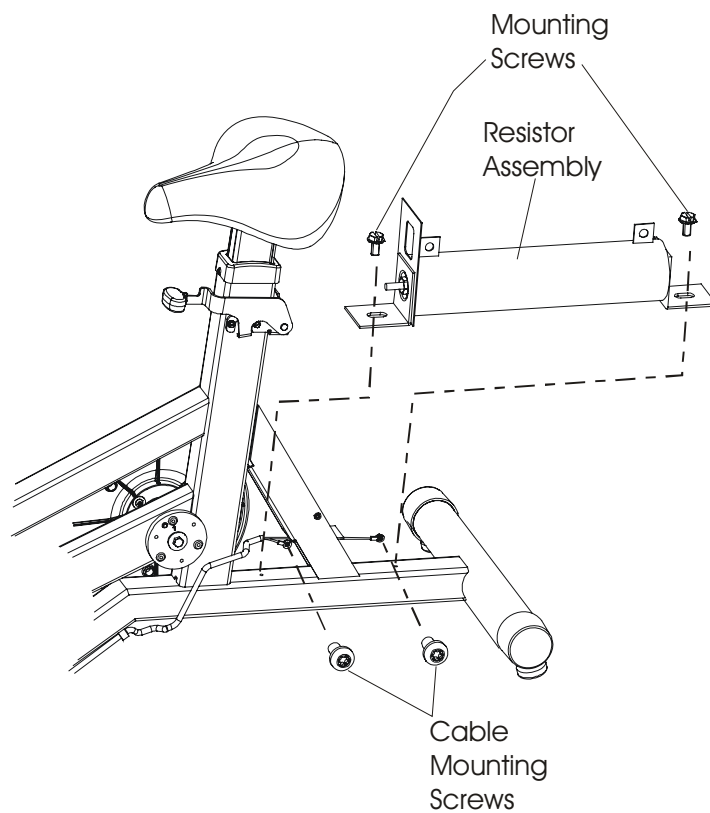

# Lifecycle Upright Bikes LC95, LC91, LC85, C9, C7, 95Ce, 95Ci, 93Ci, and 90C

## How To... Remove the Auto Start Switch and Bracket

Special Service Tools: NONE

**CAUTION! BEFORE REPLACING CIRCUIT BOARD(S), GROUND YOURSELF TO EARTH GROUND USING AN ANTI-STATIC GROUND STRAP.**

1. Remove the side shrouds. Refer to How To in this section.
2. Disconnect the auto start switch cable from the left side of the unit at the PCB.

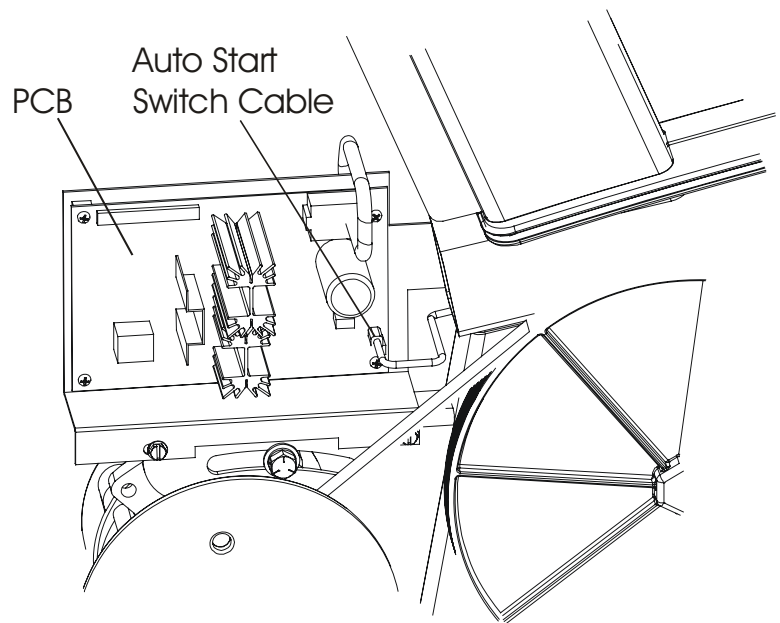

3. Remove the screw securing the auto start switch to the right side of the upper frame.
4. Remove the cable and switch, and if necessary the mounting bracket by removing the one mounting screw.
5. Install new cable and switch in reverse order.

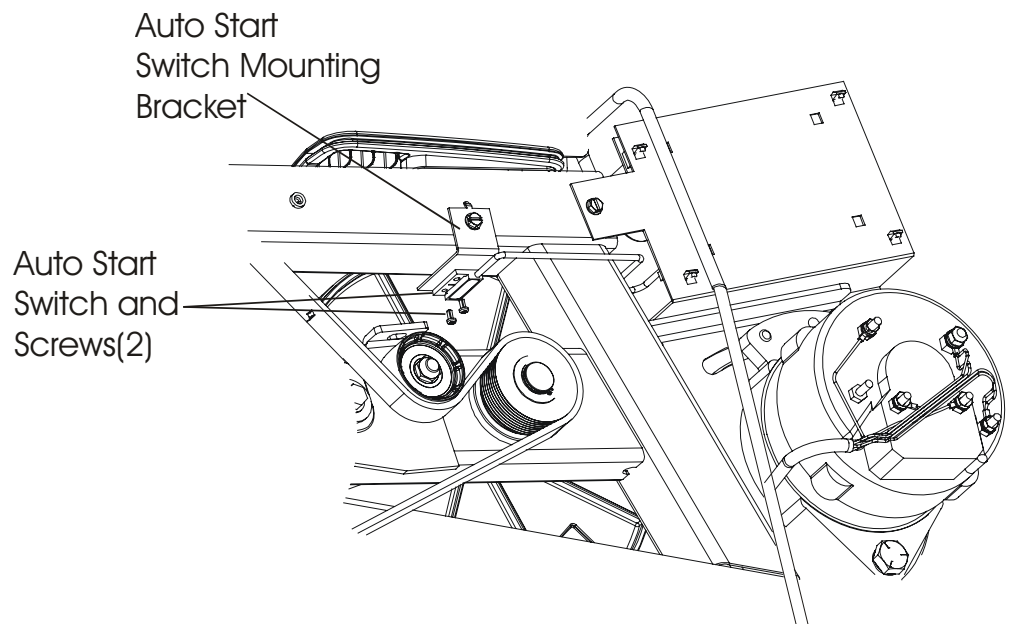

## Lifecycle Upright Bikes LC95, LC91, LC85, C9, C7, 95Ce, 95Ci, 93Ci, and 90C How To... Remove the Console PCB

Special Service Tools: NONE

**CAUTION! BEFORE REPLACING CIRCUIT BOARD(S), GROUND YOURSELF TO EARTH GROUND USING AN ANTI-STATIC GROUND STRAP.**

1. Remove the battery cover and battery.
2. Remove the four screws under the console, securing the console to the console support.
3. Lift the console up just enough to disconnect the main cable.
4. Remove eight screws from the back of the console and split the halves.
5. Remove the screws securing the PCB to the front half of the console, and remove the PCB.
6. Discard the PCB, and install new PCB in the console in the reverse order.
7. Reconnect console and secure onto the console support with the mounting screws.

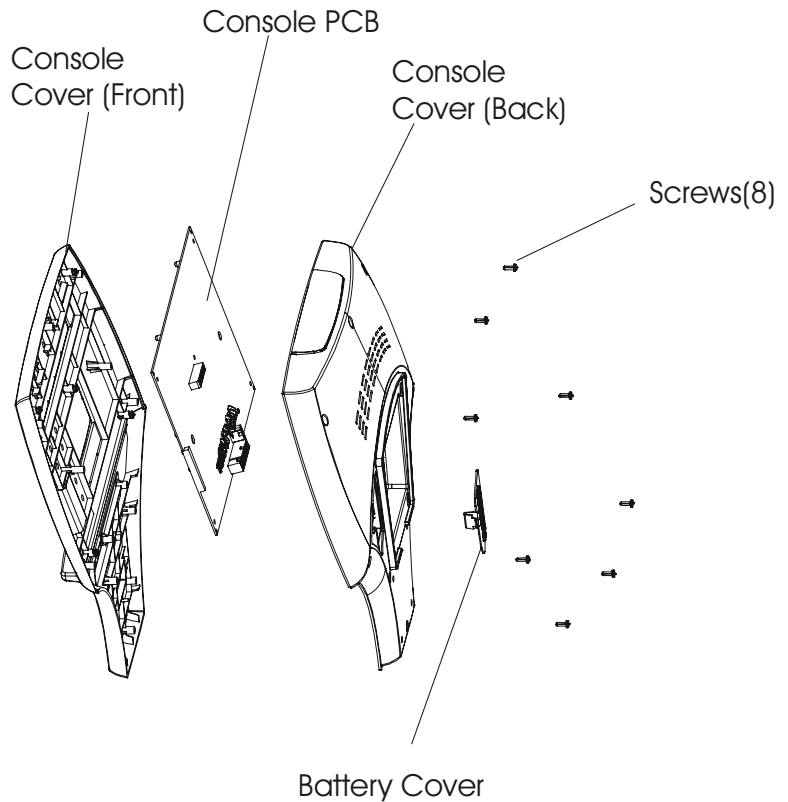

# Lifecycle Upright Bikes LC95, LC91, LC85, C9, C7, 95Ce, 95Ci, 93Ci, and 90C LCD Integrated Console Service Overview

Special Service Tools Required: NONE

**CAUTION! BEFORE REPLACING CIRCUIT BOARD(S), GROUND YOURSELF TO EARTH GROUND USING AN ANTI-STATIC GROUND STRAP.**

**NOTE:** The following pages provide service procedures for servicing the LCD Integrated Console. While the Console Housings may differ between the various products, the internal components, which make up the Console, are identical. Use the exploded view below to help identify parts and component location during service.

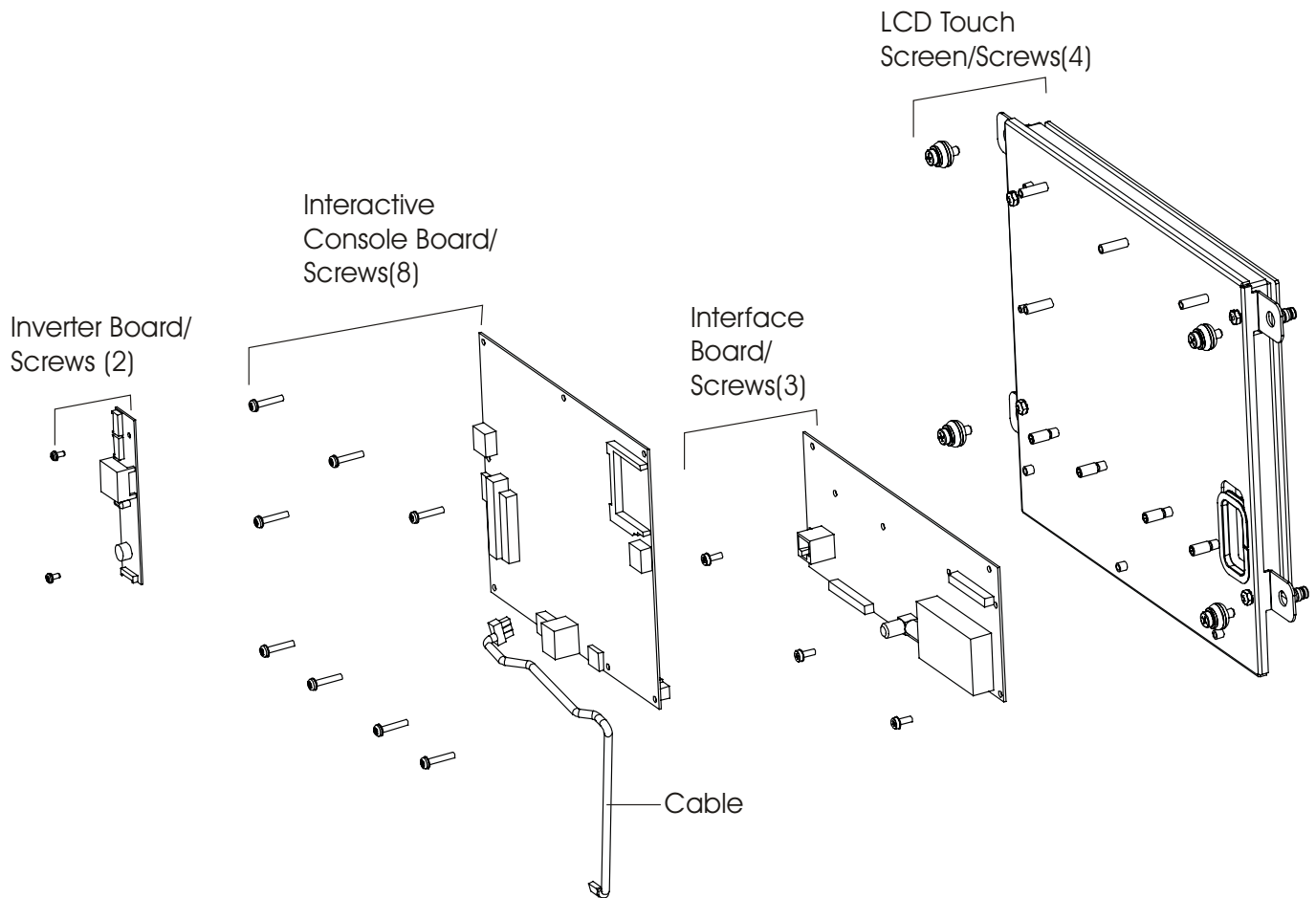

## Lifecycle Upright Bikes LC95, LC91, LC85, C9, C7, 95Ce, 95Ci, 93Ci, and 90C

### How To... Replace the Headphone Jack

Special Service Tools Required: NONE

---

**CAUTION! BEFORE REPLACING CIRCUIT BOARD(S), GROUND YOURSELF TO EARTH GROUND USING AN ANTI-STATIC GROUND STRAP.**

Note: For clarity purposes the Console is shown off the unit. Headphone Jack replacement does not require removal of the Console from the unit.

1. At the bottom of the Console, remove the Phillip Screw securing the Headphone Jack.
2. Remove the Headphone Jack from the Console.
3. Install new Headphone Jack in reverse order.

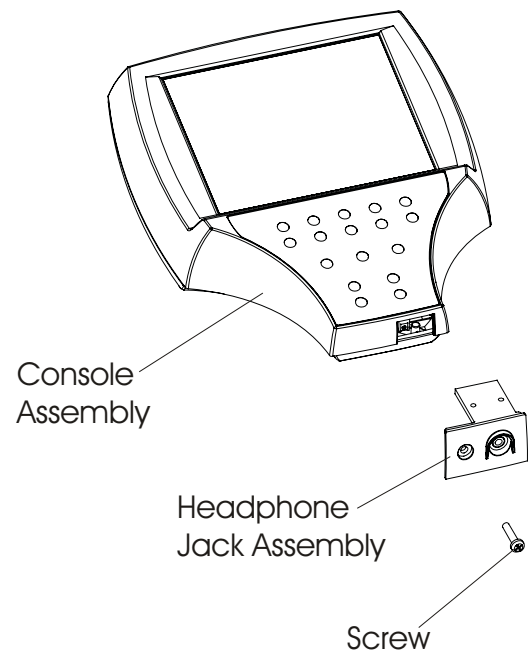

# Lifecycle Upright Bikes LC95, LC91, LC85, C9, C7, 95Ce, 95Ci, 93Ci, and 90C

## How To... Replace the Inverter Board

Special Service Tools Required: NONE

**CAUTION! BEFORE REPLACING CIRCUIT BOARD(S), GROUND YOURSELF TO EARTH GROUND USING AN ANTI-STATIC GROUND STRAP.**

1. Remove console from unit refer to Display Console and Accessory Tray Removal.
2. Remove seven screws from the Back Cover and lift the Back Cover off.

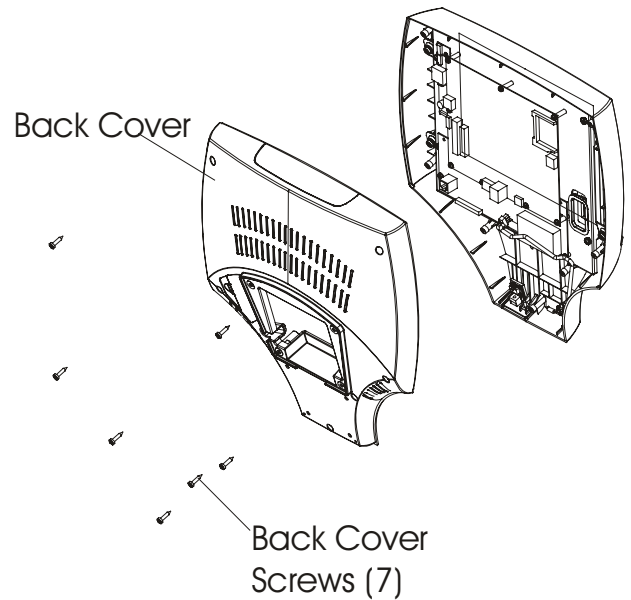

3. Disconnect the Pink/White Power Wire Connectors (2) from the top of the Inverter Board, and the 4-Yellow Wires Connector, which receives Power from the PC to the Inverter, at the bottom of the Inverter Board.
4. Remove two Phillips screws securing the Inverter Board to the back of the LCD Touch Screen and lift it out.
5. Install new Inverter Board in reverse order.

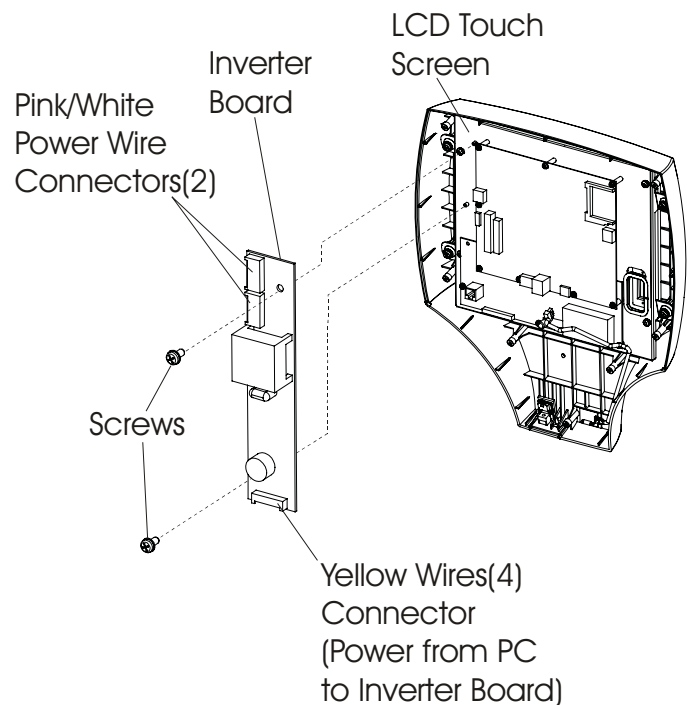

# Lifecycle Upright Bikes LC95, LC91, LC85, C9, C7, 95Ce, 95Ci, 93Ci, and 90C

## How To... Replace the Single Board Computer

Special Service Tools Required: NONE

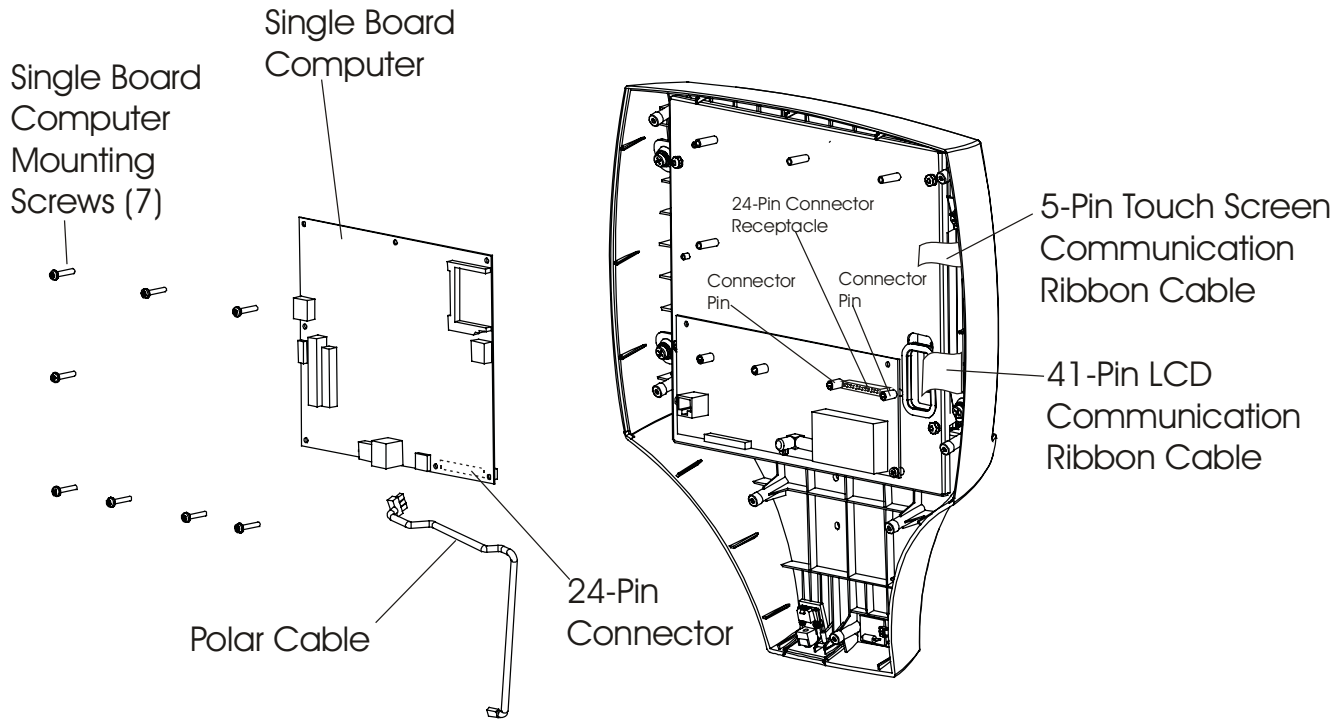

**CAUTION! BEFORE REPLACING CIRCUIT BOARD(S), GROUND YOURSELF TO EARTH GROUND USING AN ANTI-STATIC GROUND STRAP.**

1. Remove console from unit refer to Display Console and Accessory Tray Removal.
2. Remove seven screws from the Back Cover.
3. Disconnect all of the cables from the Single Board Computer.
4. Remove seven screws securing the Single Board Computer to the back of the LCD Touch Screen. The Single Board Computer remains engaged into a 24-Pin Connector Receptacle, which is located between two Connector Pins on the Interface Board. Carefully wiggle the Single Board Computer up and out of the Interface Board Connector Receptacle and Connector Pins.
5. Install Board in reverse order. Been careful on connecting the single board computer to the machine interface board.



## Lifecycle Upright Bikes LC95, LC91, LC85, C9, C7, 95Ce, 95Ci, 93Ci, and 90C How To... Replace the Interface Board

Special Service Tools Required: NONE

---

**CAUTION! BEFORE REPLACING  
CIRCUIT BOARD(S), GROUND  
YOURSELF TO EARTH GROUND USING  
AN ANTI-STATIC GROUND STRAP.**

1. Remove console from unit refer to Display Console and Accessory Tray Removal.
2. Remove seven screws from the Back Cover.
3. Remove Single Board Computer
4. Disconnect all Cables from the interface board.
5. Remove 5 screws securing the Interface Board to the mounting bracket.

**CAUTION! HIGH VOLTAGE ON INTERFACE  
BOARD CONNECTORS J2 AND J3.**

6. Remove the Interface Board.
7. Install board in reverse order. Be careful on connecting the single board computer to the machine interface board.

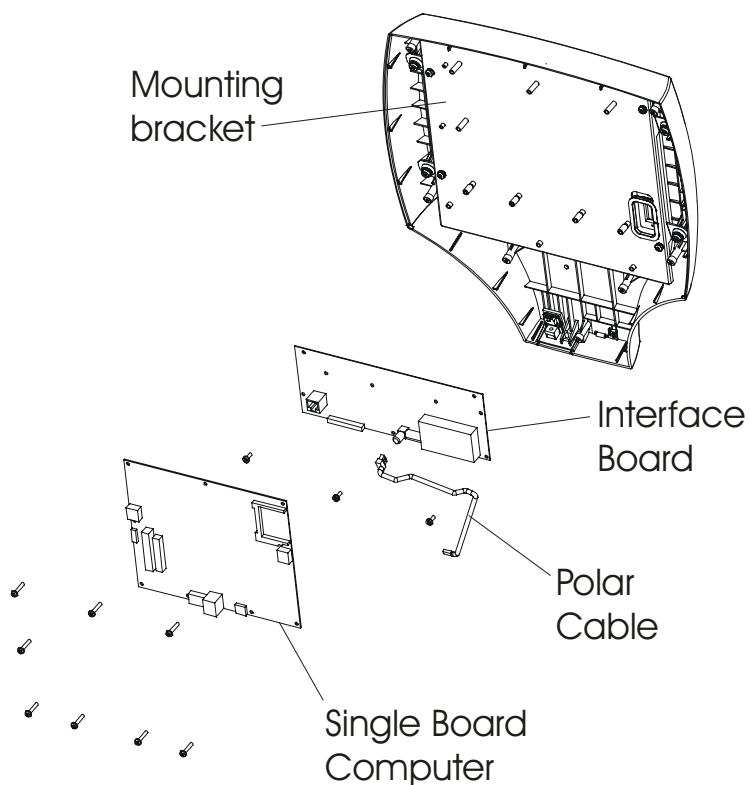

# Lifecycle Upright Bikes LC95, LC91, LC85, C9, C7, 95Ce, 95Ci, 93Ci, and 90C

## How To... Replace the Touch Screen Assembly

Special Service Tools Required: NONE

**CAUTION! BEFORE REPLACING CIRCUIT BOARD(S), GROUND YOURSELF TO EARTH GROUND USING AN ANTI-STATIC GROUND STRAP.**

1. Remove console from unit refer to Display Console and Accessory Tray Removal.
2. Remove seven screws from the Back Cover.
3. Remove the Single Board Computer. See "How To Replace the Single Board Computer" in this section.
4. Remove the Interface Board. See "How To Replace the Interface Board" in this section.
5. Remove the Inverter Board. See "How To Replace the Inverter Board" in this section.
6. Remove four screws securing the Touch Screen Bracket Assembly to the bezel Assembly. Remove the Touch Screen Assembly from the Console.
7. Remove the four nuts securing the LCD/touch screen to the bracket then separate the bracket from the assembly.
8. Install new Touch Screen in reverse order.

