

SECTION III

How To...

SERVICE AND REPAIR

	Page
Side Shrouds and Crank Arms.....	3
Drive Belt	4
Alternator Belt	5
Crank Shaft Hub Assembly	6
Crank Shaft Bearings	7
Clutch Assembly.....	10
Intermediate Pulley Shaft and Bearings	11
Idler Roller	16
Alternator.....	17
Seat Locking Mechanism	19
Seat Assembly and Extrusion	20
Adjust Seat Rollers.....	21
Seat Pad and Handlebar Assembly	22
Locking Rack.....	23
Accessory Tray.....	24
Main Cable	25
Heart Rate Cable.....	26
Polar Receiver.....	27
Alternator Cable	28
Reed Switch and Cable.....	29
9-Volt Battery (LC8500R and R7)	30
6-Volt Battery (LC95R, LC91R, and R9)	31
Display Console and Console Support.....	32
Power Control Board	33
Pedal	34
Front Wheel Assembly	35
Adjustable Levelers	36
Resistor Assembly.....	37
Console Circuit Board	38
Console Service Overview	39
Headphone Jack	40
Inverter Board.....	41
Single Board Computer.....	42
Interface Board.....	43
Touch Screen Assembly	44

NOTES

Lifecycle Recumbent Bikes LC95R, LC91R, LC85R, R9, R7, 95Ri, 93Ri, 90R, and 95Re

How To... Replace the Side Shrouds and Crank Arms

Special Service Tools: NONE

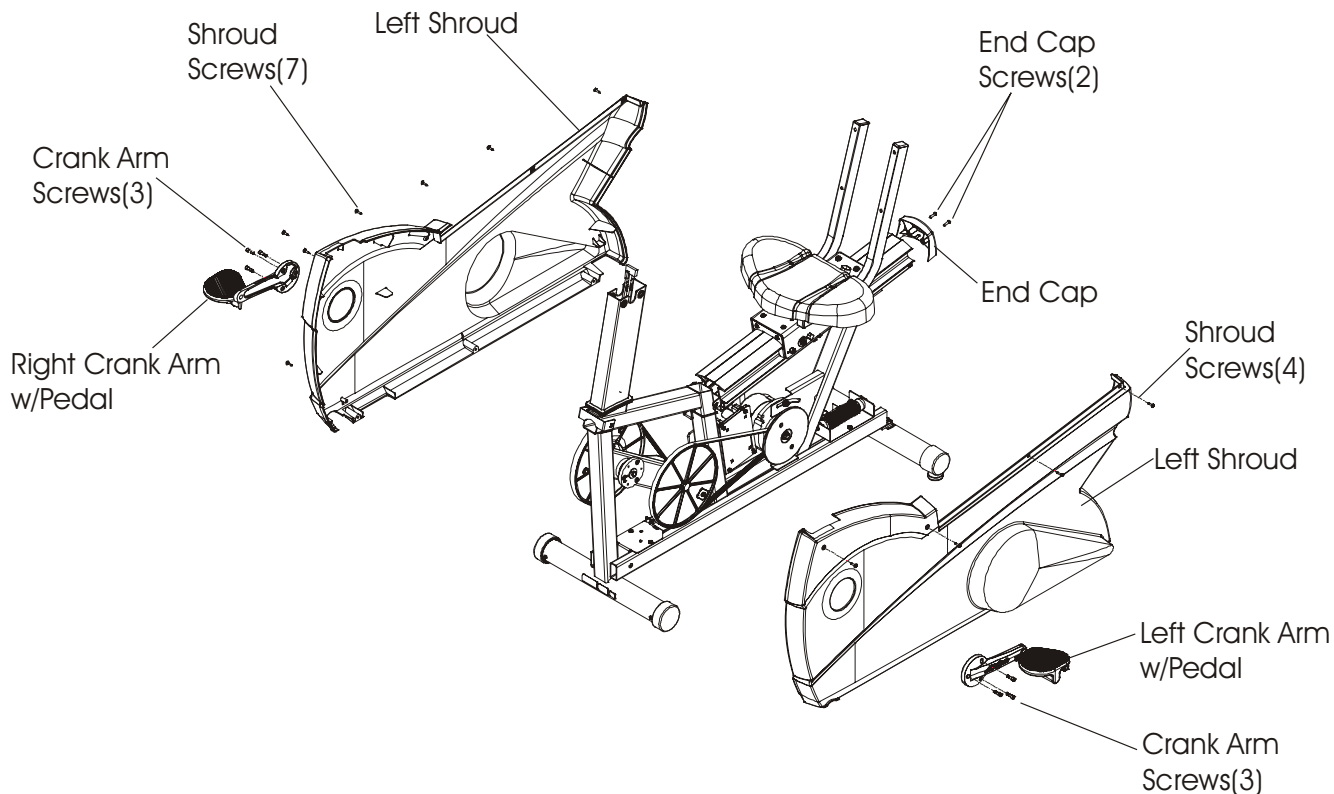

Note: To remove the side shrouds, it will be necessary to remove both pedals and crank arms, and the end cap. Use the illustrations on this page to aid in this procedure.

1. Remove three screws from the left and right crank hubs, and then remove the crank arms with pedals attached.
2. Remove two screws from the end cap at the end of the frame which allows access to the left and right side shroud screws.
3. Remove the left and right side shroud screws, and then remove the side shrouds. Discard shrouds.
4. Install new side shrouds in reverse order. Torque the shroud screws 12-15 in lbs.
5. Torque crank arm screws 15-20 ft lbs.

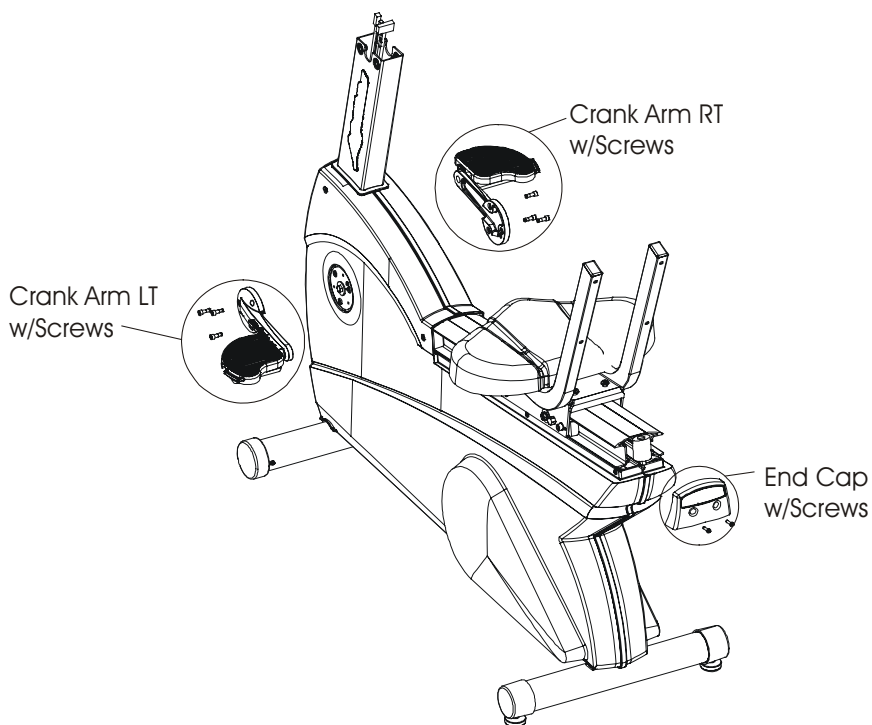

Note: The Crank Arm Screws should not be reused more than five times.

Lifecycle Recumbent Bikes LC95R, LC91R, LC85R, R9, R7, 95Ri, 93Ri, 90R, and 95Re

How To... Remove the Drive Belt

Special Service Tools: NONE

Note: An access hole in the crank pulley allows removal or loosening of the idler bracket bolt with a socket.

1. Remove the right side shroud. See "How To..." in this section.
2. Rotate the crank pulley until the idler bracket mounting bolt is visible through the access hole in the crank pulley, then loosen the bolt.
3. Loosen the belt tension by loosening the adjusting bolt on the idler bracket.
4. Remove old belt and discard.
5. Install new belt in reverse order.
6. Adjust belt tension 100-110 lbs by moving the idler bracket down. Insert a straight blade screwdriver in the slotted lip of the bracket to obtain specified tension. When belt tension is achieved, then tighten the mounting bolt and adjustable bracket bolt. Remove the right shroud. See "How To..." in this section.

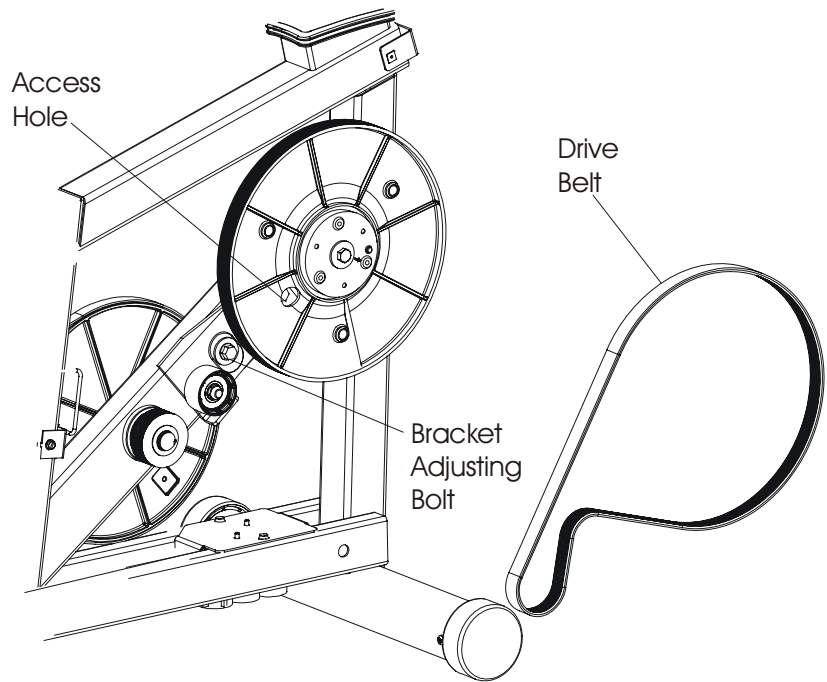

Lifecycle Recumbent Bikes LC95R, LC91R, LC85R, R9, R7, 95Ri, 93Ri, 90R, and 95Re

How To... Replace the Alternator Belt

Special Service Tools: NONE

1. Remove the side shrouds. See “How To...” in this section.
2. Index the location of the tensioning bolt to the alternator mounting bracket, and then loosen the tensioning bolt.
3. Loosen the pivot bolt, and then rotate the alternator until the belt can be removed from the alternator pulley and the intermediate pulley.

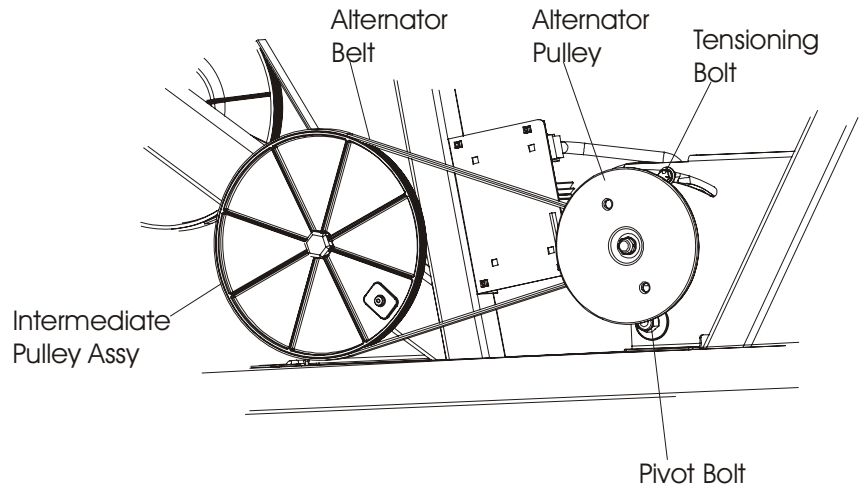

4. Install new alternator belt in reverse order. Position the alternator belt on the far left groove of the alternator flywheel pulley (towards user side) and in the center of the alternator pulley (large pulley). Then tighten the belt back to the index mark or 70-80 lbs.

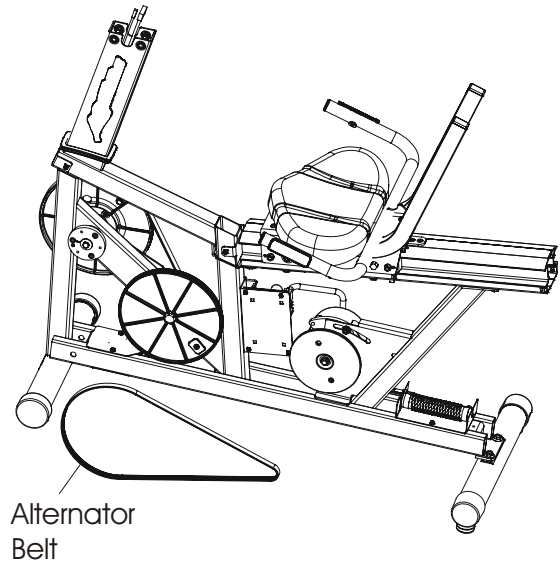

Alternator Belt

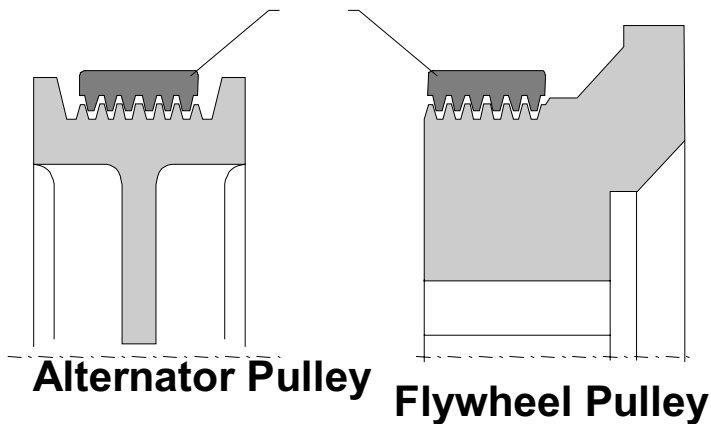

Lifecycle Recumbent Bikes LC95R, LC91R, LC85R, R9, R7, 95Ri, 93Ri, 90R, and 95Re

How To... Replace the Crank Shaft Hub Assembly

Special Service Tools: Bearing Service Tool Kit – Part Number: [BearingToolKit](#)

Note: The left shroud does not require removal to service the left crank shaft hub.

1. Remove the right crank arm and shroud. See “How To...” in this section.
2. Remove the drive belt. See “How To...” in this section.
3. Remove the bolt and washer in the center of the hub.

NOTE: There is an arrow mark on each hub which is located 180 degrees apart, and is used for proper crank arm position.

4. Install the disc puller plate as illustrated on the left hub.
5. Turn the puller forcing bolt clockwise until the left hub is removed. Discard the hub.

NOTE: The right hub is removed with the crank shaft pulley attached. Use the puller as described in left hub removal. Once off, remove the three screws at the back of the pulley to separate it from the hub.

NOTE: Make sure the arrow mark on the hub is pointing 180 degrees from the other hub.

6. Position the new hub on the crank shaft with the washer. Install the mounting bolts and tighten evenly until the hub is fully seated on the shaft. Torque: 220-240 in lbs.

Note: The Crank Arm Screws should not be reused more than five times.

NOTE: If the right hub was replaced, then install the hub back on the pulley first and secure using the three mounting screws.

7. Reinstall the side shrouds, crank arms, and pedals.

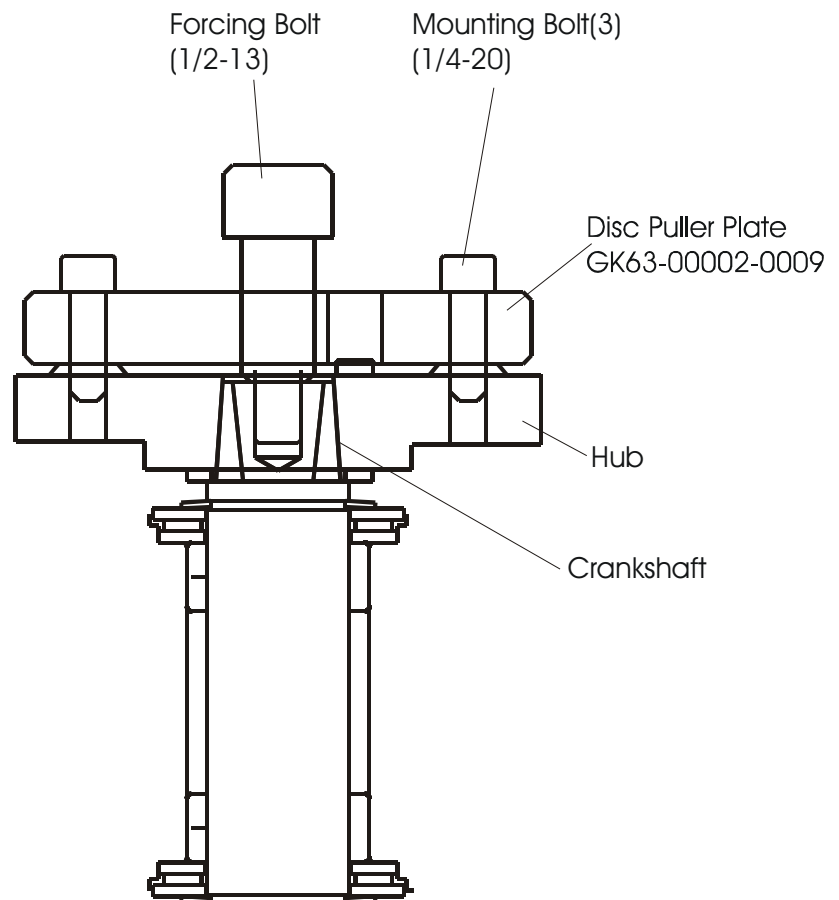
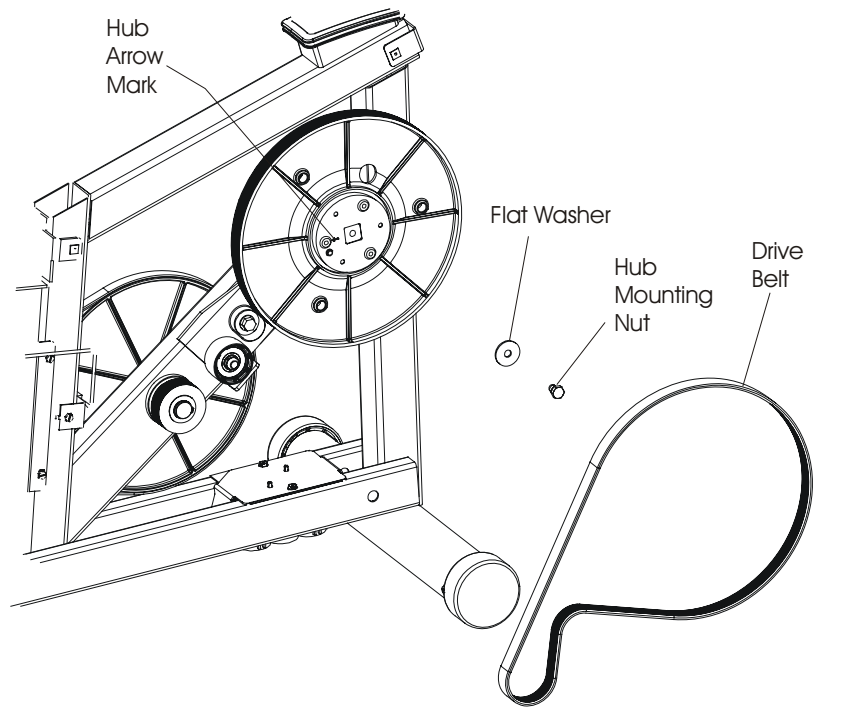

REMOVING THE HUB

Lifecycle Recumbent Bikes LC95R, LC91R, LC85R, R9, R7, 95Ri, 93Ri, 90R, and 95Re

How To... Replace the Crank Shaft Bearings

Special Service Tools: Bearing Service Tool Kit – Part Number: **BearingToolKit**

1. Remove the side shrouds. See "How To..." in this section.
2. Remove the main drive belt. See "How To ... " in this section.
3. Remove the crank shaft hubs. See "How To..." in this section.
4. Remove the large snap rings, the bowed snap rings, the large and small thrust washers, and the thrust bearings from both sides of the crank shaft.
5. Push the crank shaft out from the frame bearings.
6. Inspect, and if necessary, replace any crank shaft component parts before reassembling onto the new crank shaft.
7. Install the bearing puller on the crank frame bearings as illustrated.

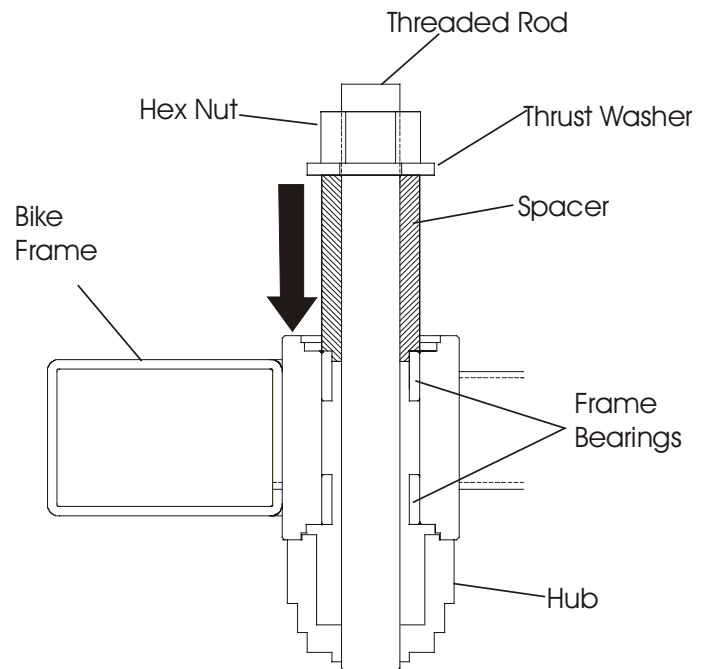
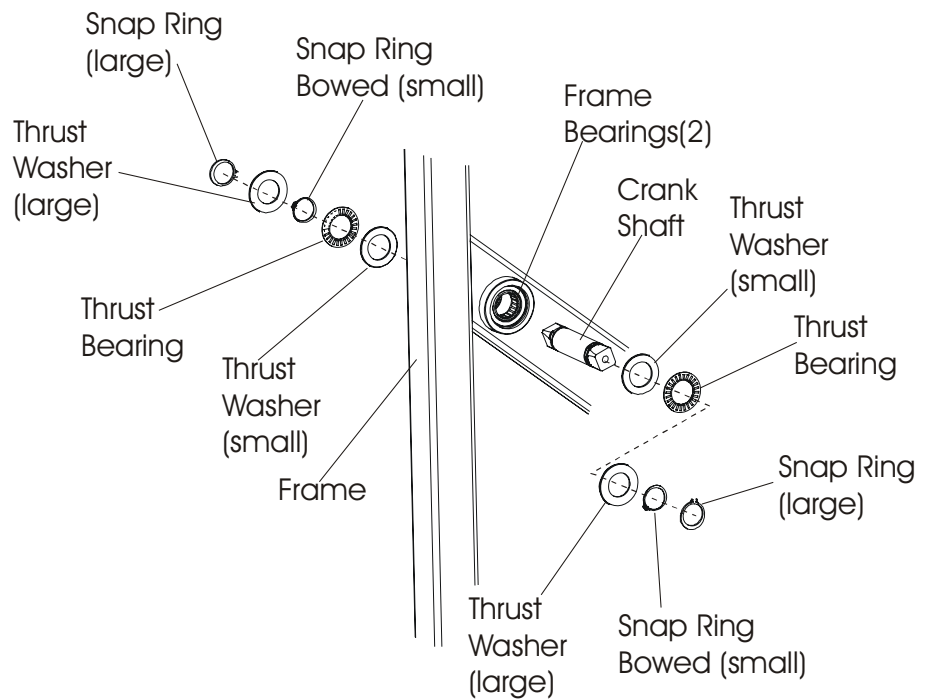

INSTALLING CRANK BEARING KIT

Lifecycle Recumbent Bikes LC95R, LC91R, LC85R, R9, R7, 95Ri, 93Ri, 90R, and 95Re

How To... Replace the Crank Shaft Bearings - Continued

Special Service Tools: Bearing Service Tool Kit – Part Number: **BearingToolKit**

8. Press out the frame bearings by rotating the hex nut clockwise until the bearings drop into the puller hub. Once the bearings are out of the frame, disassemble the puller assembly, and discard the bearings.
9. Clean the housing before installing new frame bearings.

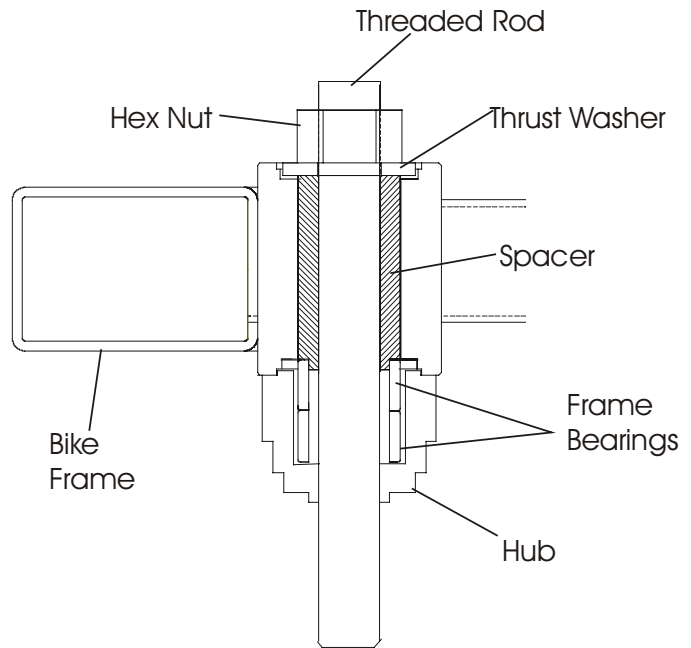

PUSHING OUT FRAME BEARINGS INTO THE HUB

10. Position the new frame bearings with markings (on the face of the bearings), positioned facing out. Make sure bearings are aligned straight and square.

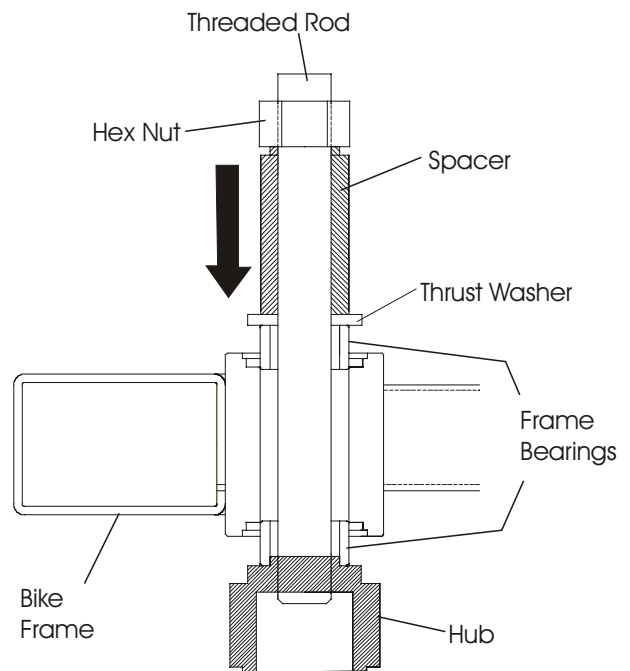

INSTALLING NEW FRAME BEARINGS

Lifecycle Recumbent Bikes LC95R, LC91R, LC85R, R9, R7, 95Ri, 93Ri, 90R, and 95Re

How To... Replace the Crank Shaft Bearings - Continued

Special Service Tools: Bearing Service Tool Kit – Part Number: **BearingToolKit**

11. Start tightening the hex nut. You may have to hold the spacer to stop it from turning.
12. Continue pressing in the new frame bearings until the thrust washer and hub stop against the frame housing shoulder. Make sure that the bearing races seat flush against the inner hub face.

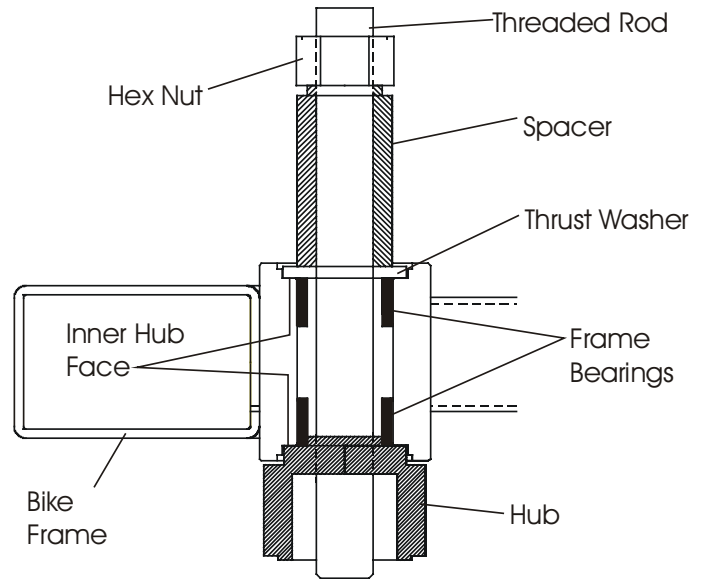

PRESSING IN NEW BEARINGS

13. Reinstall crank shaft and components. Use the exploded view below to aid in reassembly.
14. Reinstall the hubs.
15. Reinstall the main drive belt.
16. Reinstall the side shrouds, crank arms and pedals.

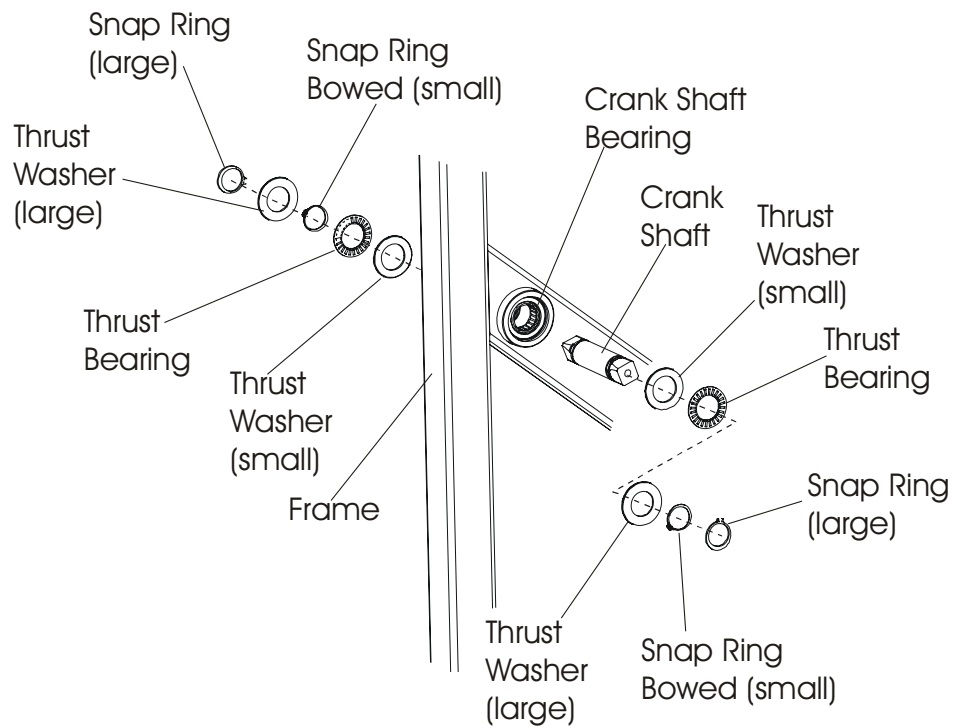

Lifecycle Recumbent Bikes LC95R, LC91R, LC85R, R9, R7, 95Ri, 93Ri, 90R, and 95Re How To... Replace the Clutch Assembly

Special Service Tools: NONE

1. Remove the right shroud. See "How To..." in this section.
2. Remove the main drive belt. See "How To..." in this section.
3. Remove the snap ring from the intermediate shaft.
4. Remove the washers and clutch assembly. Discard the clutch assembly.
5. Install the new clutch and its parts in reverse order. Make sure to install the step side going into the frame.
6. Install main drive belt.
7. Install shrouds and then pedals.

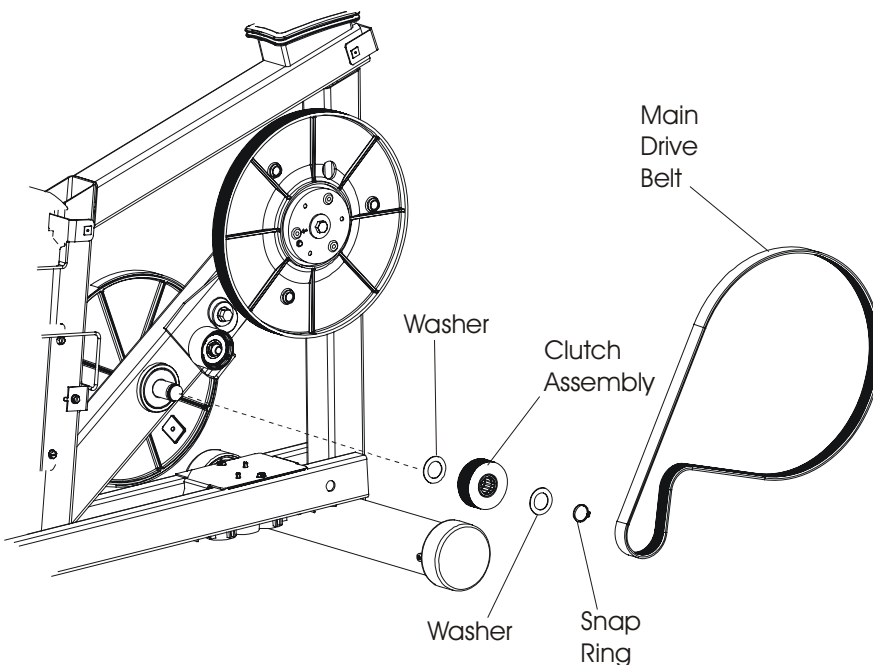

Lifecycle Recumbent Bikes LC95R, LC91R, LC85R, R9, R7, 95Ri, 93Ri, 90R, and 95Re

How To... Replace the Intermediate Pulley Shaft and Bearings

Special Service Tools: Bearing Service Tool Kit – Part Number: **BearingToolKit**

1. Remove the side shrouds. See “How To...” in this section.

2.

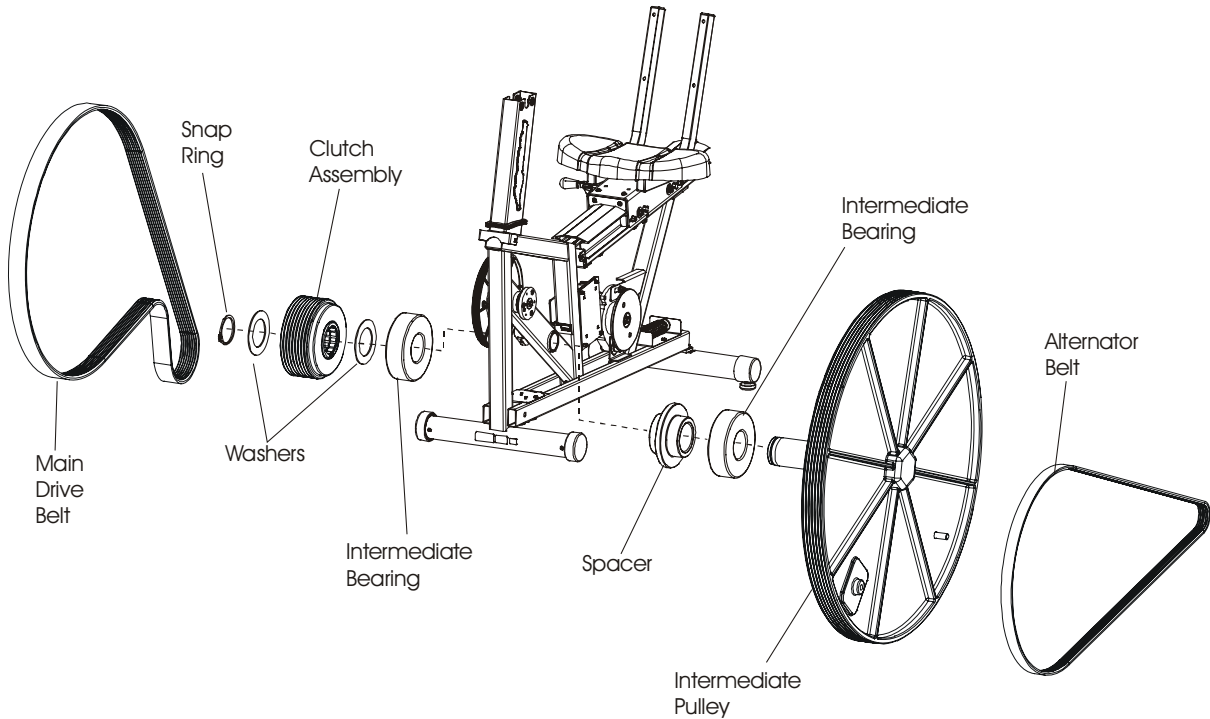

Remove the alternator and main drive belt. See “How To...” in this section.

3. Remove the clutch assembly. See “How To...” in this section.

4. Assemble 2-jaw puller to the bike frame at the intermediate pulley shaft as shown.

Note: Some bearing spacer may or may not have shoulder on spacer.

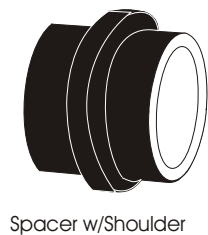
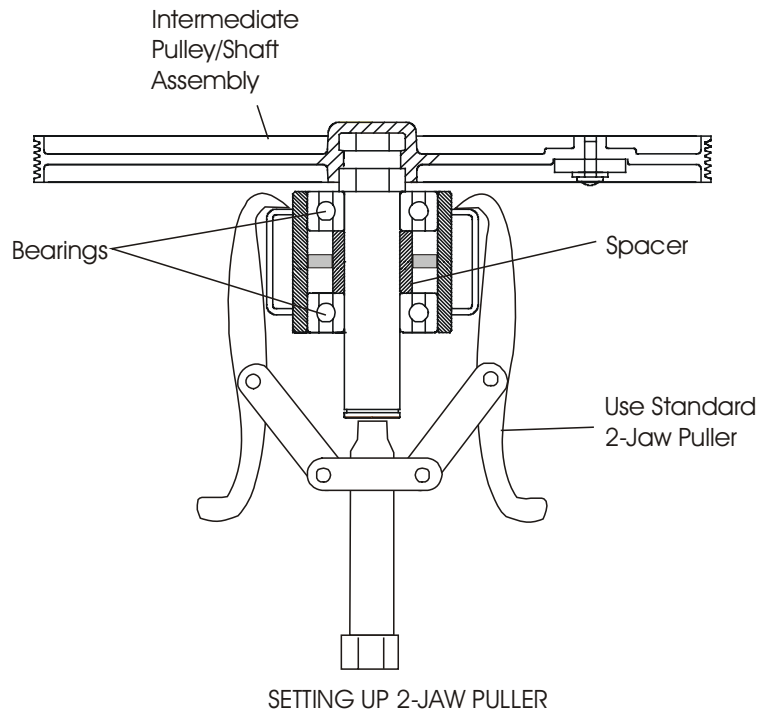

Lifecycle Recumbent Bikes LC95R, LC91R, LC85R, R9, R7, 95Ri, 93Ri, 90R, and 95Re

How To... Replace the Intermediate Pulley Shaft and Bearings - Continued

Special Service Tools: Bearing Service Tool Kit – Part Number: **BearingToolKit**

5. Turn the forcing screw clockwise to press out the pulley shaft assembly from the bearings and spacer.
6. Once the pulley shaft is free of the bearings, proceed to remove the bearings.

Note: Do Not replace the pulley without replacing the bearings.

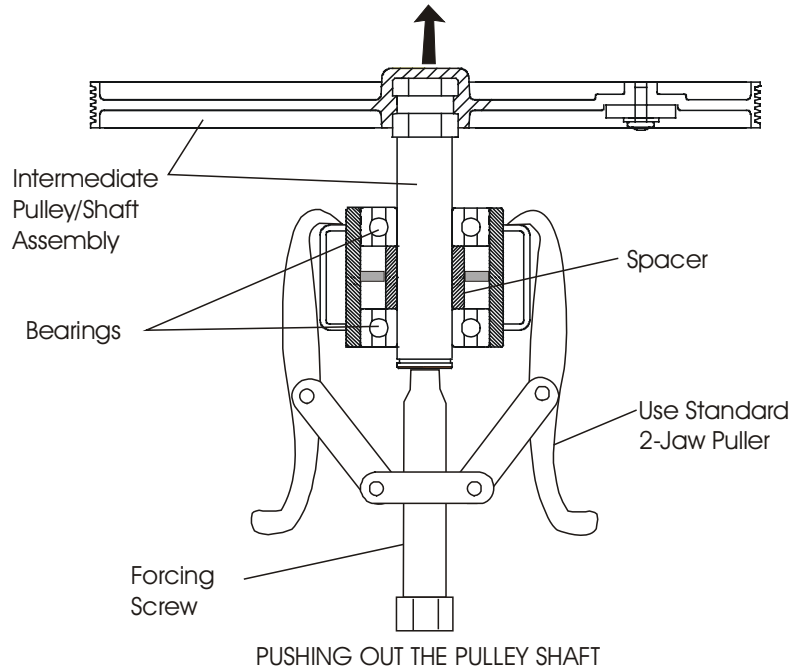

7. Install the bearing puller to the frame as illustrated.

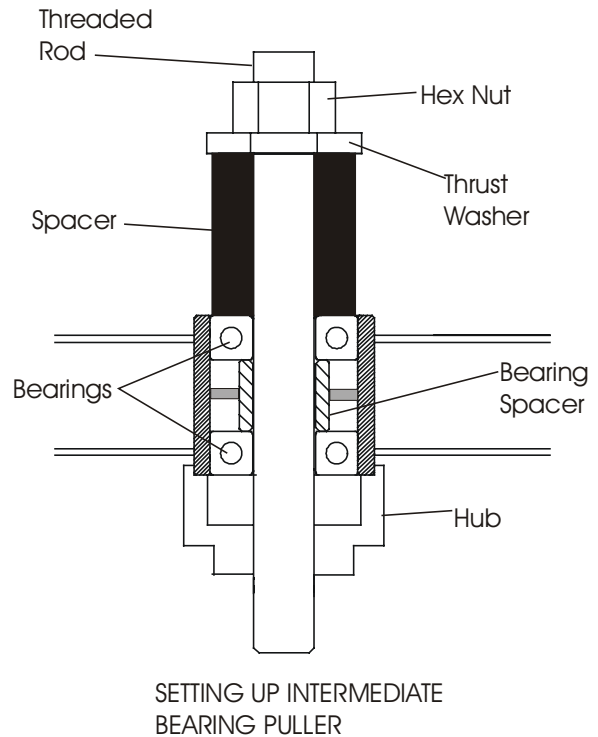

Lifecycle Recumbent Bikes LC95R, LC91R, LC85R, R9, R7, 95Ri, 93Ri, 90R, and 95Re

How To... Replace the Intermediate Pulley Shaft and Bearings - Continued

Special Service Tools: Bearing Service Tool Kit – Part Number: [BearingToolKit](#)

- Turn the hex nut clockwise to push the 1st bearing out into the hub. Loosen puller assembly and remove the 1st bearing. At this time, remove the free floating spacer.
- Retighten puller assembly and continue tightening until 2nd bearing is pressed out of its housing into the hub.
- Remove the puller and discard the bearings.
- Clean the housing.

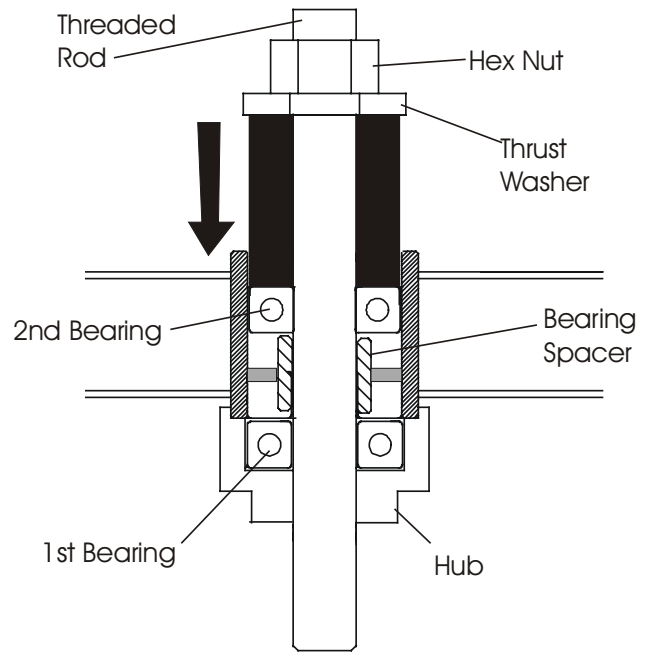

PUSHING OUT 1st BEARING

- Install the bearing spacer back in the housing, and then position the bearings in the housing.
- Install the puller assembly as shown. Make sure that the hub is reversed. Make sure all parts are aligned straight and square.

Note: The bearings MUST be pressed firmly against the bearing spacer.

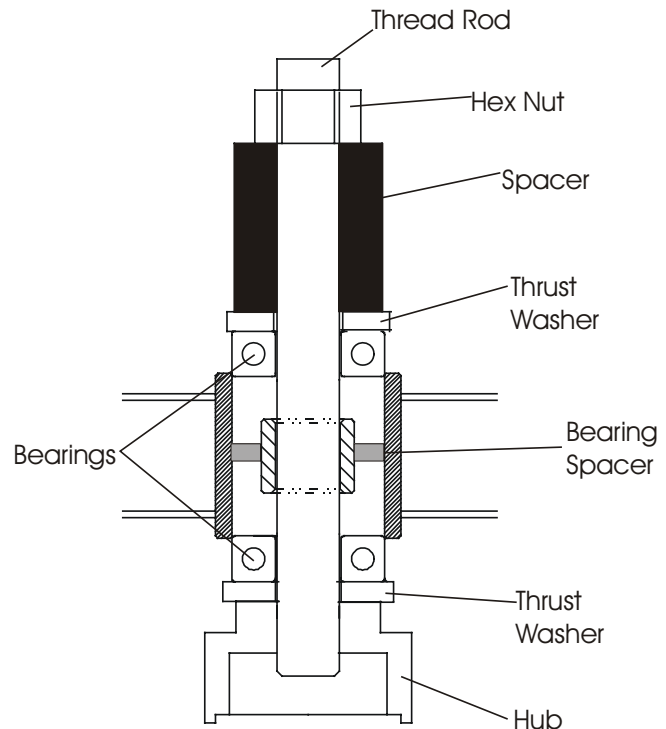

SETTING UP THE PULLER FOR PRESSING IN BEARINGS

Lifecycle Recumbent Bikes LC95R, LC91R, LC85R, R9, R7, 95Ri, 93Ri, 90R, and 95Re

How To... Replace the Intermediate Pulley Shaft and Bearings - Continued

Special Service Tools: Bearing Service Tool Kit – Part Number: [BearingToolKit](#)

- Start tightening the hex nut to press in the bearings. Continue pressing in the bearings until the thrust washers(2) stop against the housing shoulder as shown.
- Remove the puller assembly and check to see that the bearing spacer is securely held in position between the bearings. If so, proceed to press in the intermediate shaft. If the bearing spacer is loose, proceed to the next step.
- If the bearing spacer is loose, then reinstall the puller assembly without the thrust washer on the side of the intermediate pulley (see illustration below). Continue pressing in the bearing. When the bearing (next to the pulley) is properly seated against the bearing spacer, it will be slightly below flush and the puller hub will be free to spin. Proceed to press in the intermediate pulley/shaft.

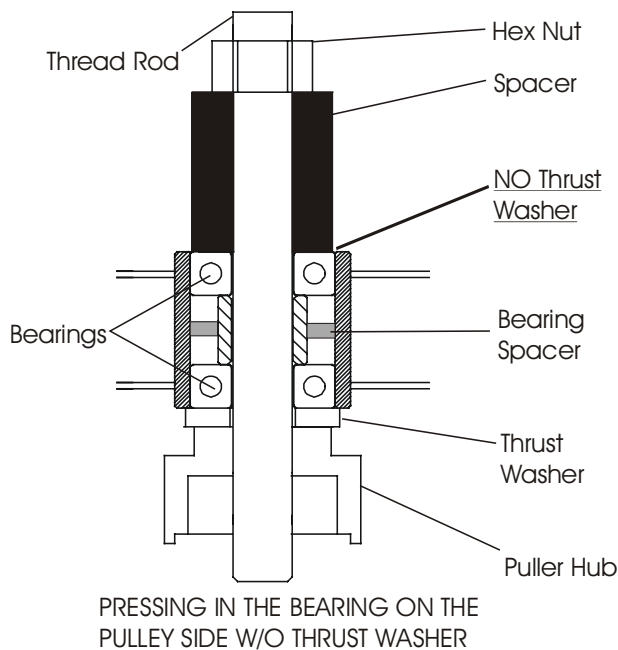
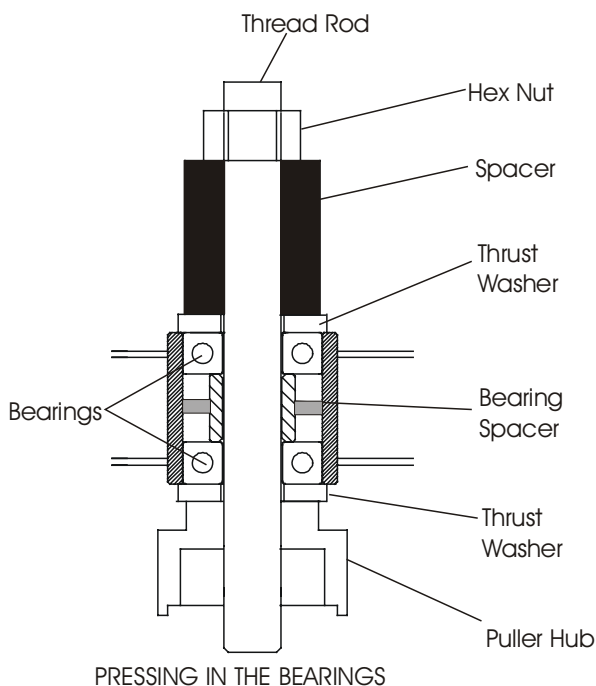

- Position the intermediate pulley/shaft in the housing. Position the swivel spacer on top of the pulley and the stop block against the bottom bearing, and then secure the C-clamp as illustrated. Make sure the shaft is aligned straight and square. Also make sure the plastic bearing spacer between the bearings is centered.

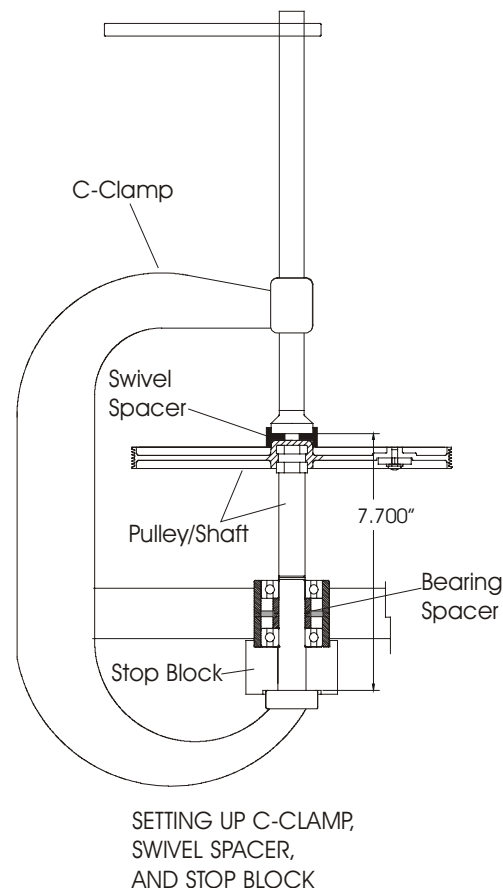

Note: Once the pulley/shaft gets started in the bearing, remove the C-Clamp to ensure the bearing spacer is in alignment to receive the shaft, and then continue to press in the pulley/shaft.

Lifecycle Recumbent Bikes LC95R, LC91R, LC85R, R9, R7, 95Ri, 93Ri, 90R, and 95Re How To... Replace the Intermediate Pulley Shaft and Bearings - Continued

Special Service Tools: Bearing Service Tool Kit – Part Number: [BearingToolKit](#)

18. Press in the pulley/shaft until the shaft bottoms against the 2nd bearing.

19. Remove the C-clamp and stop block.

20. Install the clutch assembly.

21. Reinstall alternator belts.

22. Install side shrouds and then the pedals.

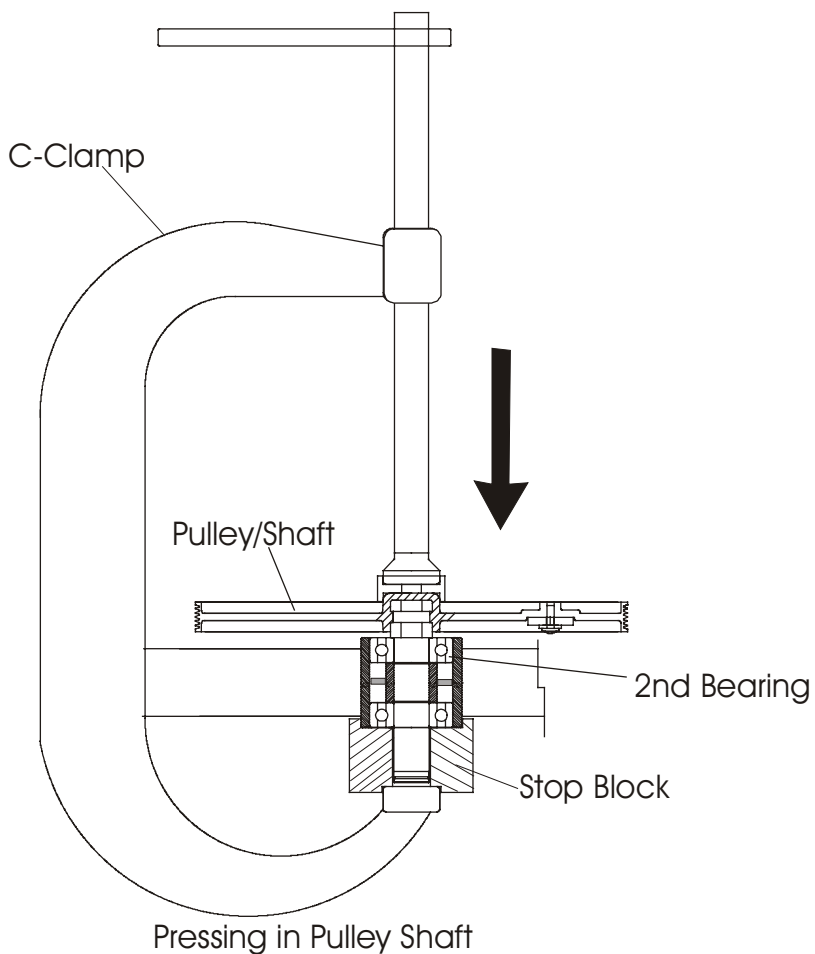

Lifecycle Recumbent Bikes LC95R, LC91R, LC85R, R9, R7, 95Ri, 93Ri, 90R, and 95Re

How To... Replace the Idler Roller

Special Service Tools: NONE

Note: An access hole in the crank pulley exist to allow a socket to access the idler bracket mounting bolt to loosen.

1. Remove the right side shroud. See "How To..." in this section.
2. Rotate the crank pulley until the idler bracket mounting bolt is visible through the access hole in the crank pulley, then loosen this bolt.
3. Loosen the belt tension by loosening the adjusting bolt on the idler bracket.
4. Remove the idler nut and pull off the idler roller. Discard idler roller.
5. Install new idler roller in reverse order.
6. Adjust belt tension 100-110 lbs by moving the idler bracket down. Insert a straight blade screwdriver in the slotted lip of the bracket to obtain specified tension. When belt tension is achieved, then tighten the mounting bolt and adjustable bracket bolt.

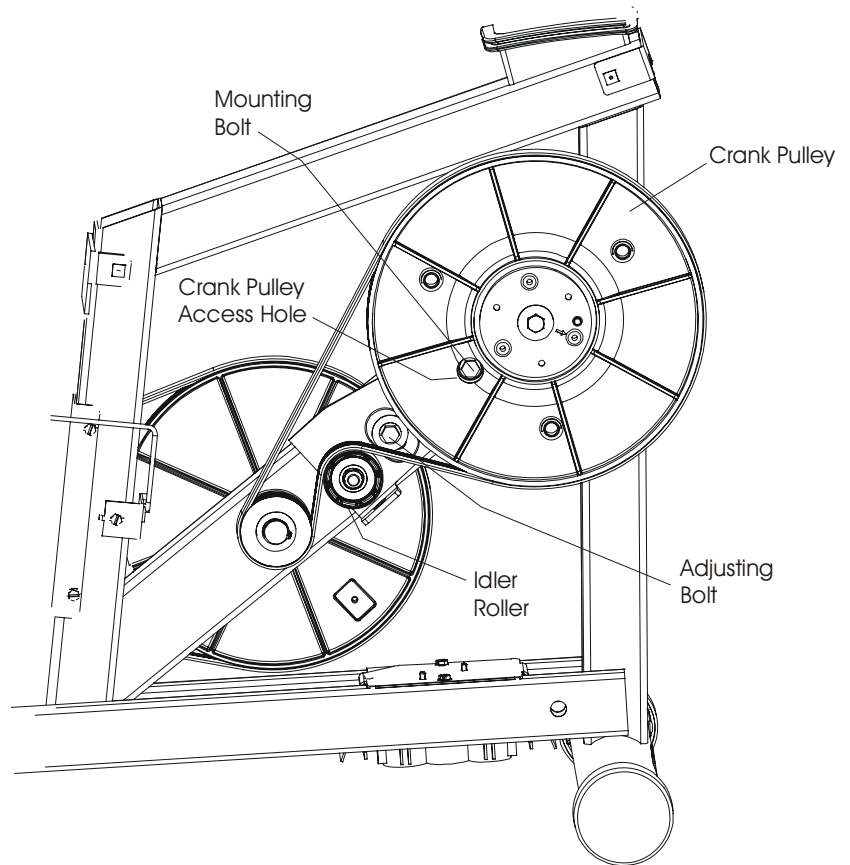

Lifecycle Recumbent Bikes LC95R, LC91R, LC85R, R9, R7, 95Ri, 93Ri, 90R, and 95Re

How To... Replace the Alternator

Special Service Tools: NONE

1. Remove the side shrouds. See "How To..." in this section.
2. Remove the alternator belt. See "How To..." in this section.
3. Disconnect the main wiring cable connector from the back of the power control board.
4. Tag and identify all wiring at the back of the alternator, and then remove them from their mounting posts.

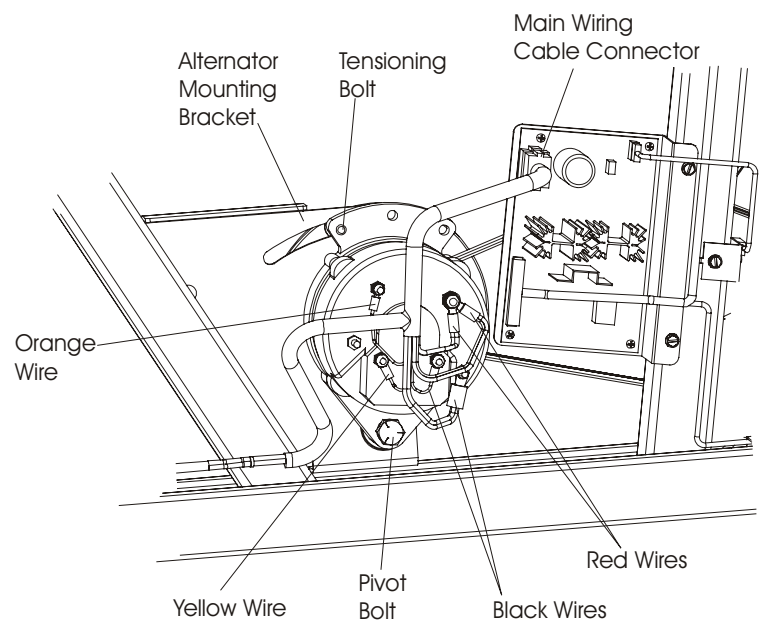

5. Index the tensioning bolt to the alternator mounting bracket, and then remove the tensioning bolt and pivot bolt.
6. Remove the alternator and install new alternator in reverse order.

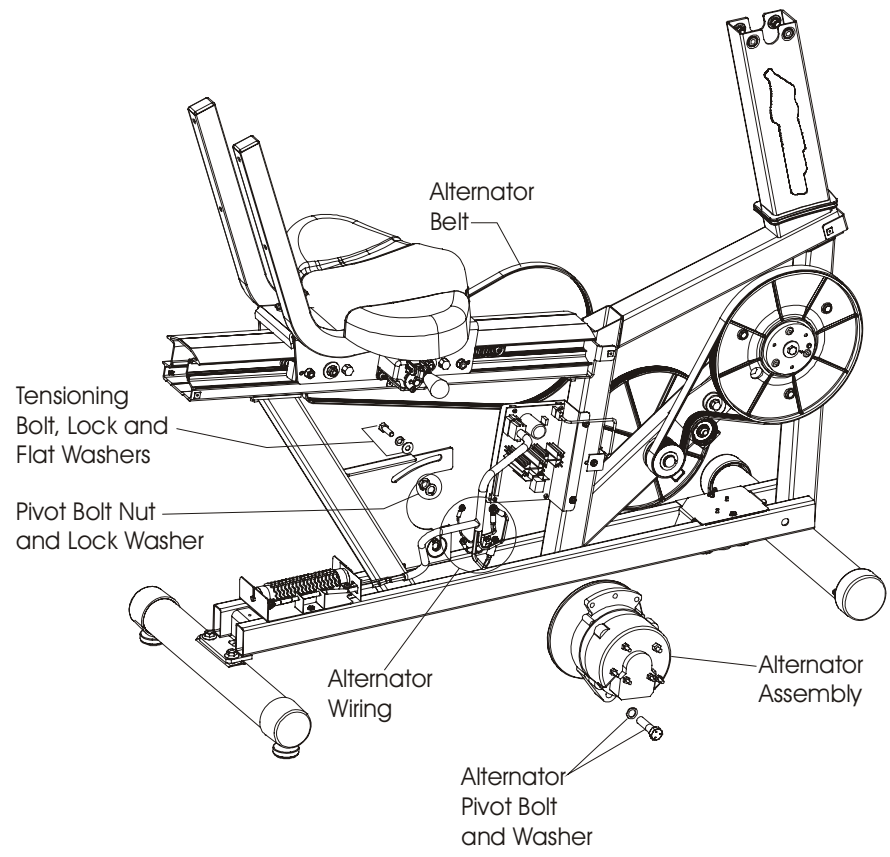

Lifecycle Recumbent Bikes LC95R, LC91R, LC85R, R9, R7, 95Ri, 93Ri, 90R, and 95Re **How To... Replace the Alternator - Continued**

Special Service Tools: NONE

7. Make sure to position the alternator belt on the far left groove of the alternator flywheel pulley (towards user side) and in the center of the alternator pulley (large pulley). Tighten the belt back to the index mark or 70-80 lbs.

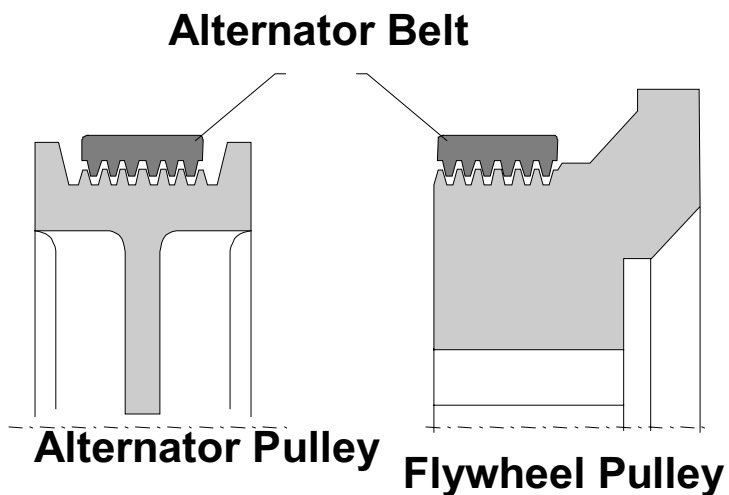

Lifecycle Recumbent Bikes LC95R, LC91R, LC85R, R9, R7, 95Ri, 93Ri, 90R, and 95Re How To... Replace the Seat Locking Mechanism

Special Service Tools: NONE

Note: Illustration shown without components or shrouds for clarity purpose.

1. Disengage the locking mechanism and slide the seat to its forward most position.
2. Remove the two 5/32 inch mounting screws from the locking mechanism.
3. Remove the locking mechanism.
4. Install new locking mechanism in reverse order.

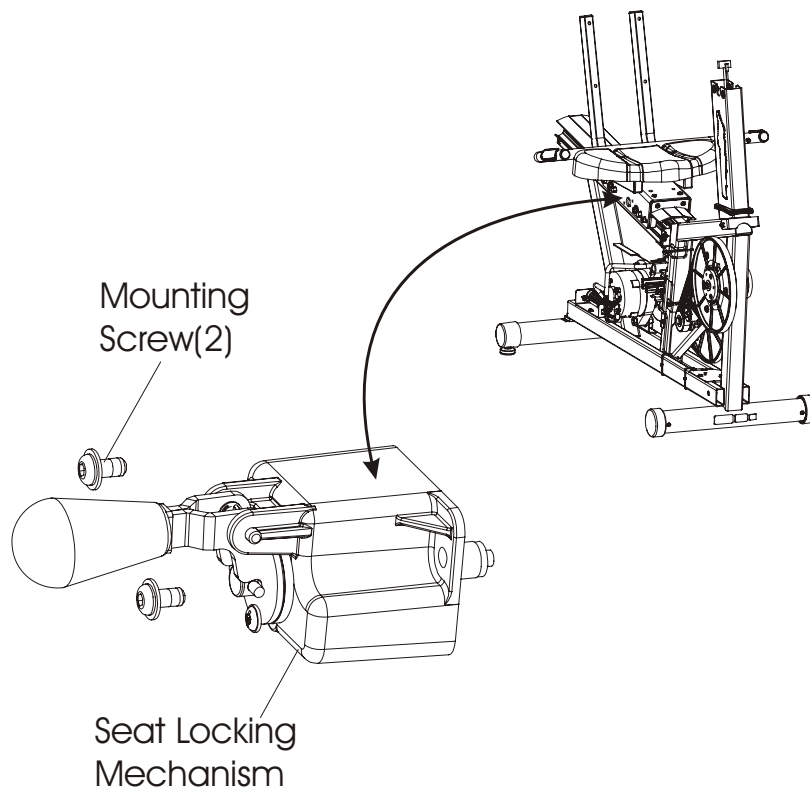

Lifecycle Recumbent Bikes LC95R, LC91R, LC85R, R9, R7, 95Ri, 93Ri, 90R, and 95Re

How To... Replace the Seat Assembly and Extrusion

Special Service Tools: NONE

1. See "How To..." replace shrouds in this section.
2. Remove the seat stop by removing two screws from the top seat assembly.
3. From under the extrusion, disconnect the flat flex connector from the main cable, then unhook the flat flex cable from the clips.
4. Disengage the locking mechanism and carefully back the seat assembly off the extrusion while guiding the flat flex cable out the seat extrusion.
5. If necessary to replace the extrusion, remove four mounting bolts under the extrusion, and lift off the extrusion.
6. Install extrusion in reverse order.
7. Install new seat assembly in reverse order of removal.
8. Adjust seat rollers. See "How To..." in this section.

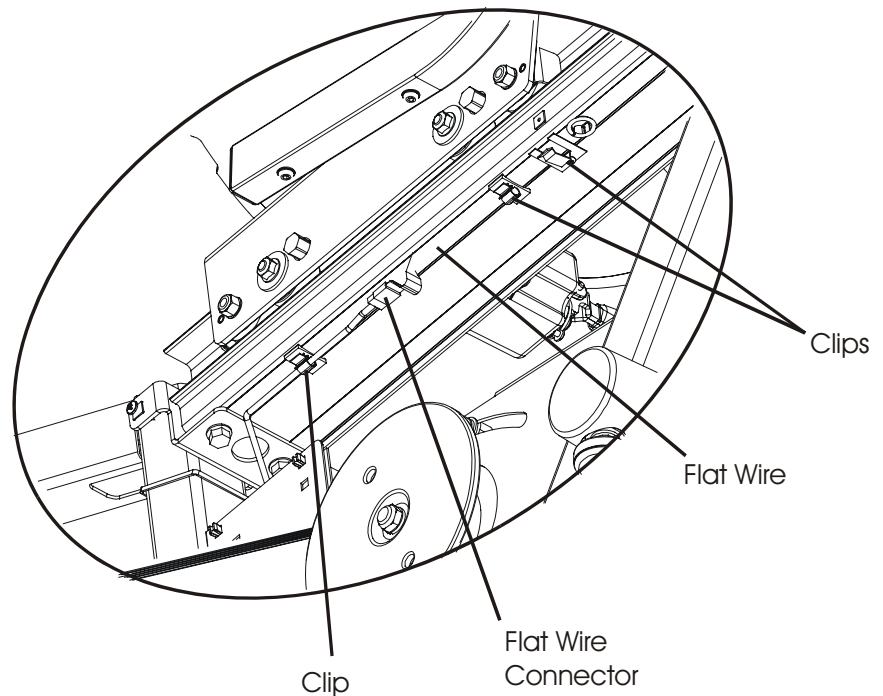
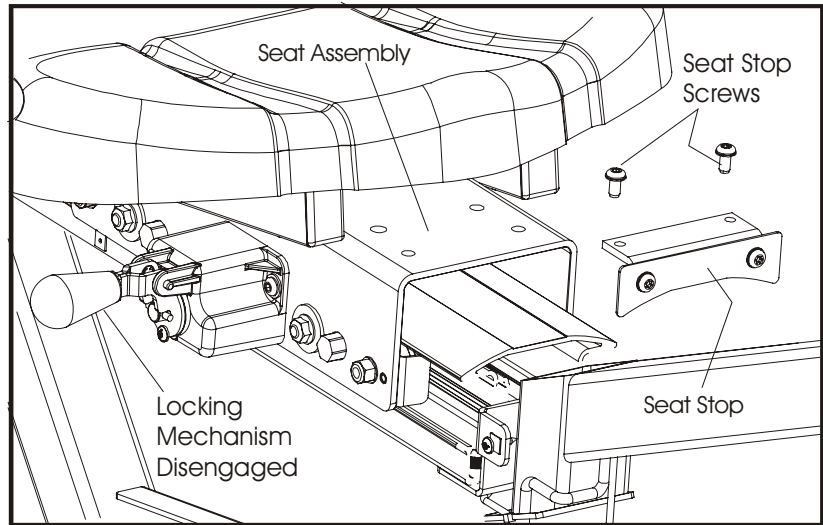

Lifecycle Recumbent Bikes LC95R, LC91R, LC85R, R9, R7, 95Ri, 93Ri, 90R, and 95Re

How To... Replace and Adjust Seat Rollers

Special Service Tools: NONE

Note:The seat rollers are adjusted to a specified resistance load. If the seat moves too freely with excessive side-to-side movement, then the seat rollers must be adjusted as follows.

1. Using a ½ inch wrench, loosen all four(4) seat roller clamp nuts, then retighten by hand.

NOTE: In this step, you must make initial adjustments to the seat rollers on the right side of the unit first. This is done to insure that the two right guide rollers are properly seated in the V-channel of the seat extrusion. Once the seat rollers on the right side are adjusted, then proceed to adjust the seat rollers on the left side of the unit.

The following requires use of two, inch pound torque wrenches. One to maintain a resistance load against the take-up roller and the other to torque the roller clamp nut.

2. Starting with the right side seat rollers, adjust the first take-up roller nut to 60-65 in. lbs. in a clockwise direction. Observe that the roller clamp nut will move up. This indicates that the seat roller is being forced up against the extrusion. Continue to maintain the 60-65 in. lbs. resistance load on the take-up roller, and secure the seat roller position by tightening the roller clamp nut from 100-120 in. lbs. Repeat this procedure for other remaining right roller. Once the right side is adjusted, repeat this procedure for the left side. Always set the right side seat rollers first. Failure to do so, will result in side-to-side seat movement.

3. With all seat rollers adjusted, test operation of the seat assembly for a 15-25 lbs. pulling force and to insure that no side-to-side movement exists. Repeat this procedure as required.

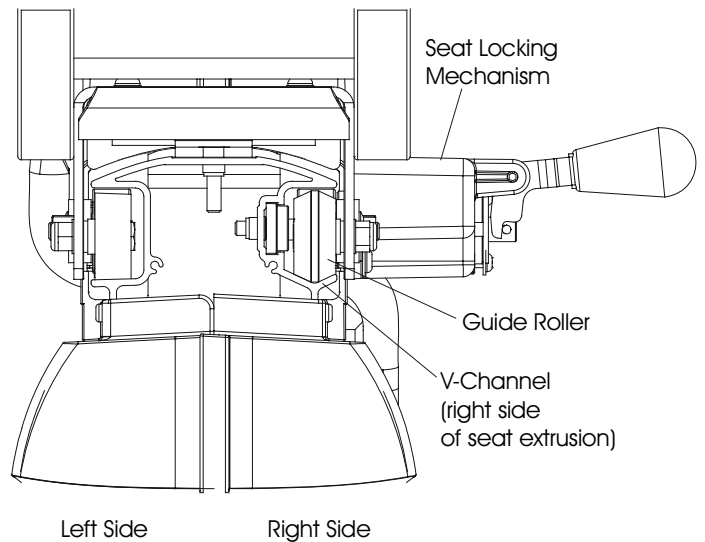
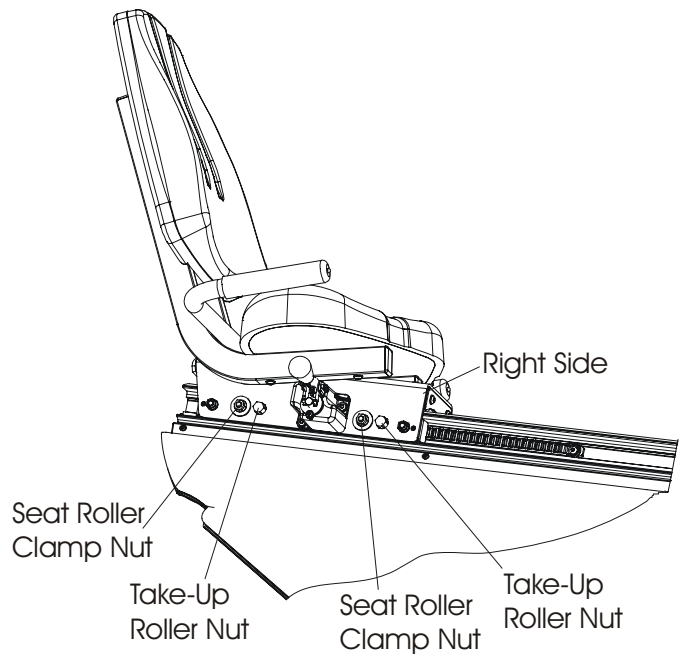

Lifecycle Recumbent Bikes LC95R, LC91R, LC85R, R9, R7, 95Ri, 93Ri, 90R, and 95Re

How To... Replace the Seat Pad and Handlebar Assembly

Special Service Tools: NONE

(Seat Pad)

1. Remove four Allen screws and washers from the frame under the seat pad, and lift off the seat pad from the seat assembly frame.

(Handlebar Assembly)

2. If equipped, disconnect the heart rate sensor connector.
3. Remove four TORX screws and washers securing the handlebar assembly to the seat assembly frame, and lift off the handlebar.

(Installation)

Install handlebar in reverse order of removal. Tighten TORX screws 160-180 in. lbs.

Install seat pad in reverse order of removal. Tighten Allen screws 55-60 in lbs.

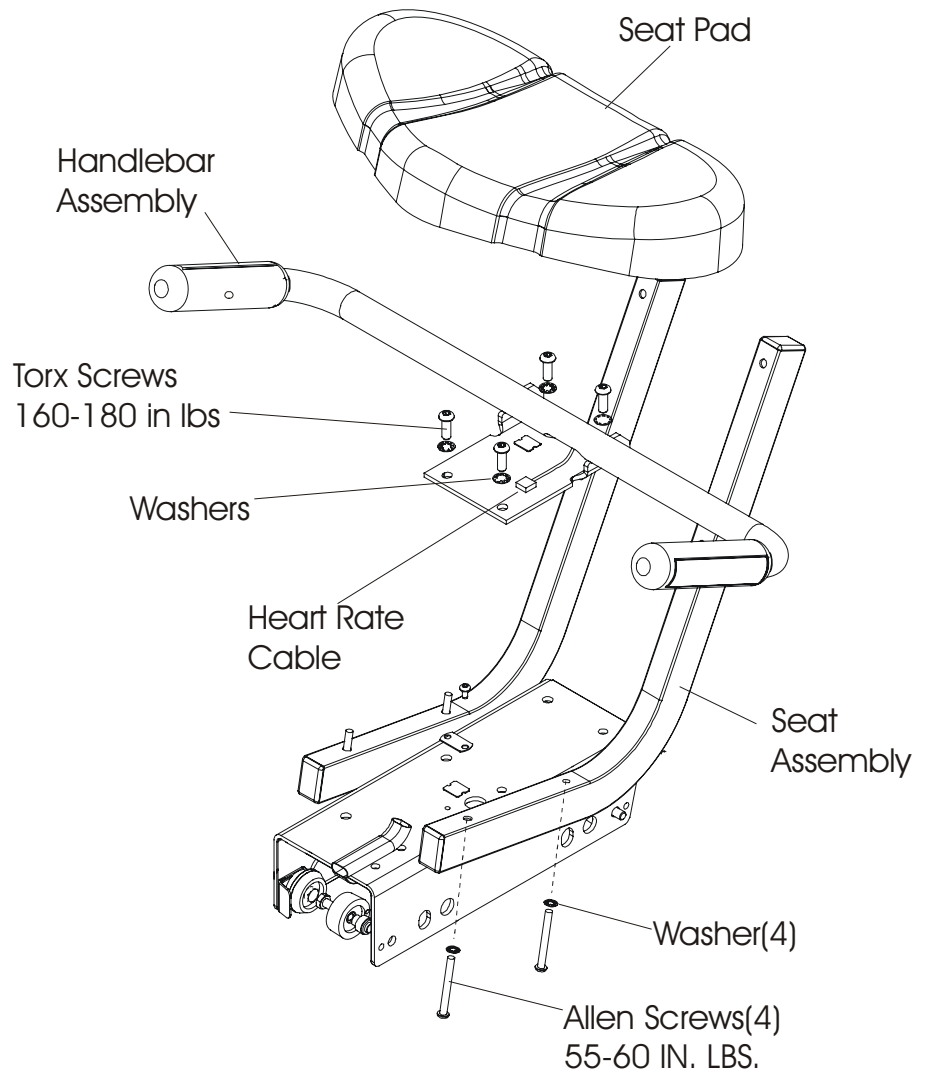

Lifecycle Recumbent Bikes LC95R, LC91R, LC85R, R9, R7, 95Ri, 93Ri, 90R, and 95Re

How To... Replace the Locking Rack

Special Service Tools: NONE

Note: The locking racking is located on the right side of the extrusion. The rack allows the locking mechanism to engage the locking rack to secure the seat assembly at a desired location along the rack. To replace the rack, proceed as follows:

1. Disengage the locking mechanism and slide seat assembly to the rear of the extrusion and lock in place.
2. Remove the Allen screw at the front of the locking rack.
3. Disengage locking mechanism and slide the seat assembly forward to the front end of the extrusion.
4. Remove the Allen screw from the rear of the locking rack.
5. Slide the locking rack out of the extrusion.
6. Replace the locking rack in the reverse order of removal. Torque the Allen screws 50-55 in lbs.

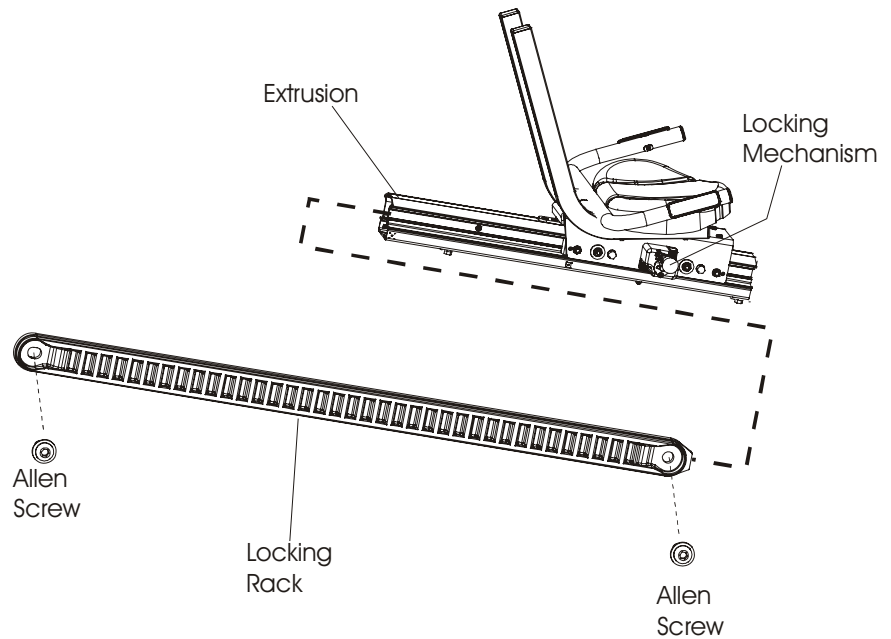

Lifecycle Recumbent Bikes LC95R, LC91R, LC85R, R9, R7, 95Ri, 93Ri, 90R, and 95Re How To... Replace the Accessory Tray

Special Service Tools: NONE

1. Remove four Allen screws and washers securing the seat back.
2. Remove the seat back and set it aside.
3. Remove the accessory tray clamp bracket from around the seat handlebar.
4. Install new accessory tray in reverse order of removal.

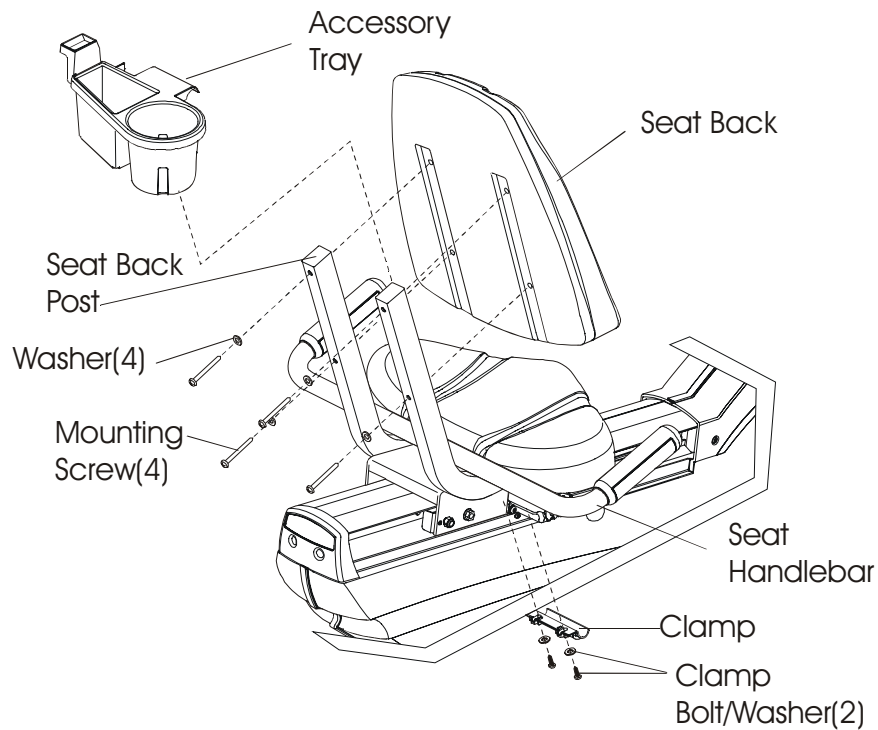

Lifecycle Recumbent Bikes LC95R, LC91R, LC85R, R9, R7, 95Ri, 93Ri, 90R, and 95Re

How To... Replace the Main Cable

Special Service Tools: NONE

1. Remove the side shrouds. See "How To..." in this section.
2. Remove the display console. See "How To..." in this section.
3. Remove the console support assembly. See "How To..." in this section.
4. Disconnect the main cable (10-pin connector) from the power control board (PCB).
5. Disconnect two wires from the 6V Battery. Disconnect the BLACK (neg) wire from the (-) terminal and the RED (pos) wire from the (+) terminal.
6. Cut the cable ties along the frame.
7. Disconnect the main cable 10-pin connector from the power control board (PCB).
8. Pull the main cable out from the console post.
9. Install new main cable through the console post in reverse order.

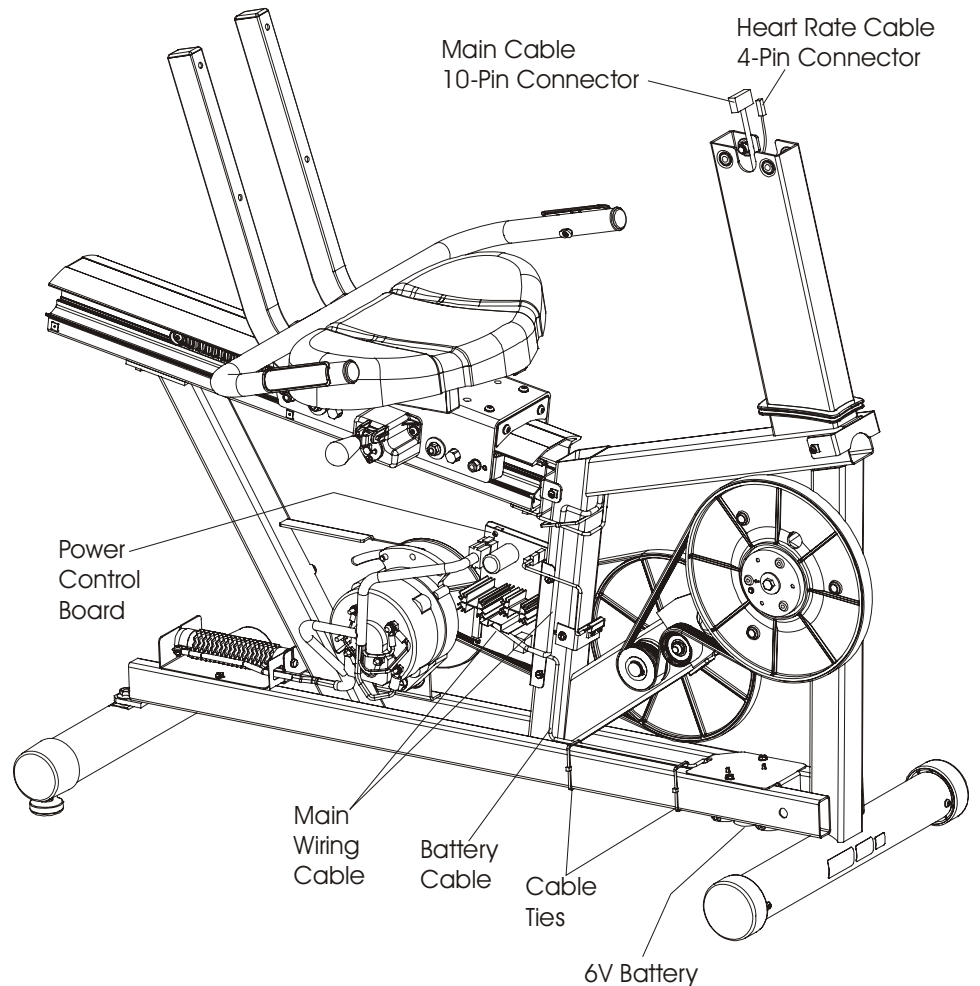
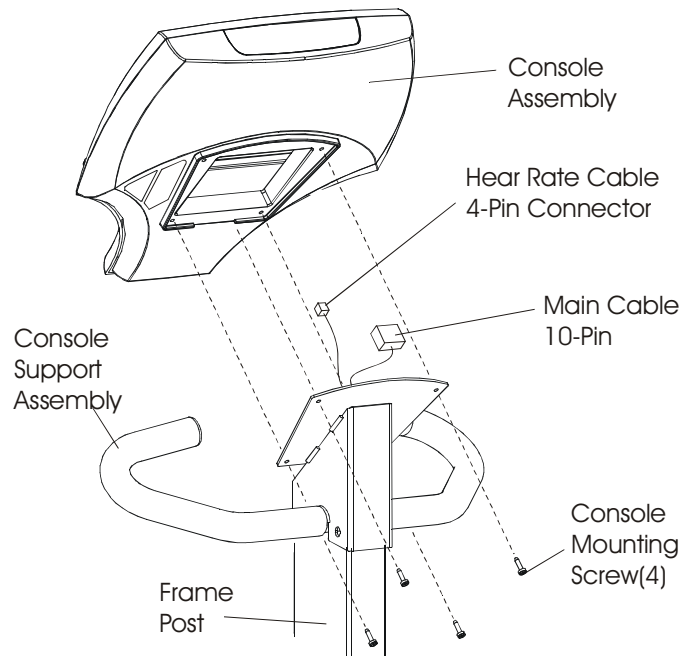

Lifecycle Recumbent Bikes LC95R, LC91R, LC85R, R9, R7, 95Ri, 93Ri, 90R, and 95Re

How To... Replace the Heart Rate Cable

Special Service Tools: NONE

1. Remove the side shrouds. See "How To..." in this section.
2. Remove the display console from the console support assembly and then, disconnect the main cable and the heart rate cable. See "How To..." in this section.
3. Disconnect the heart rate cable (4-pin connector) from flex cable under the bottom frame.
4. Remove the heart rate cable from the clip along the bottom of the frame.
5. Pull the heart rate cable out from the console post.
6. Install new heart rate cable through the console post in reverse order.

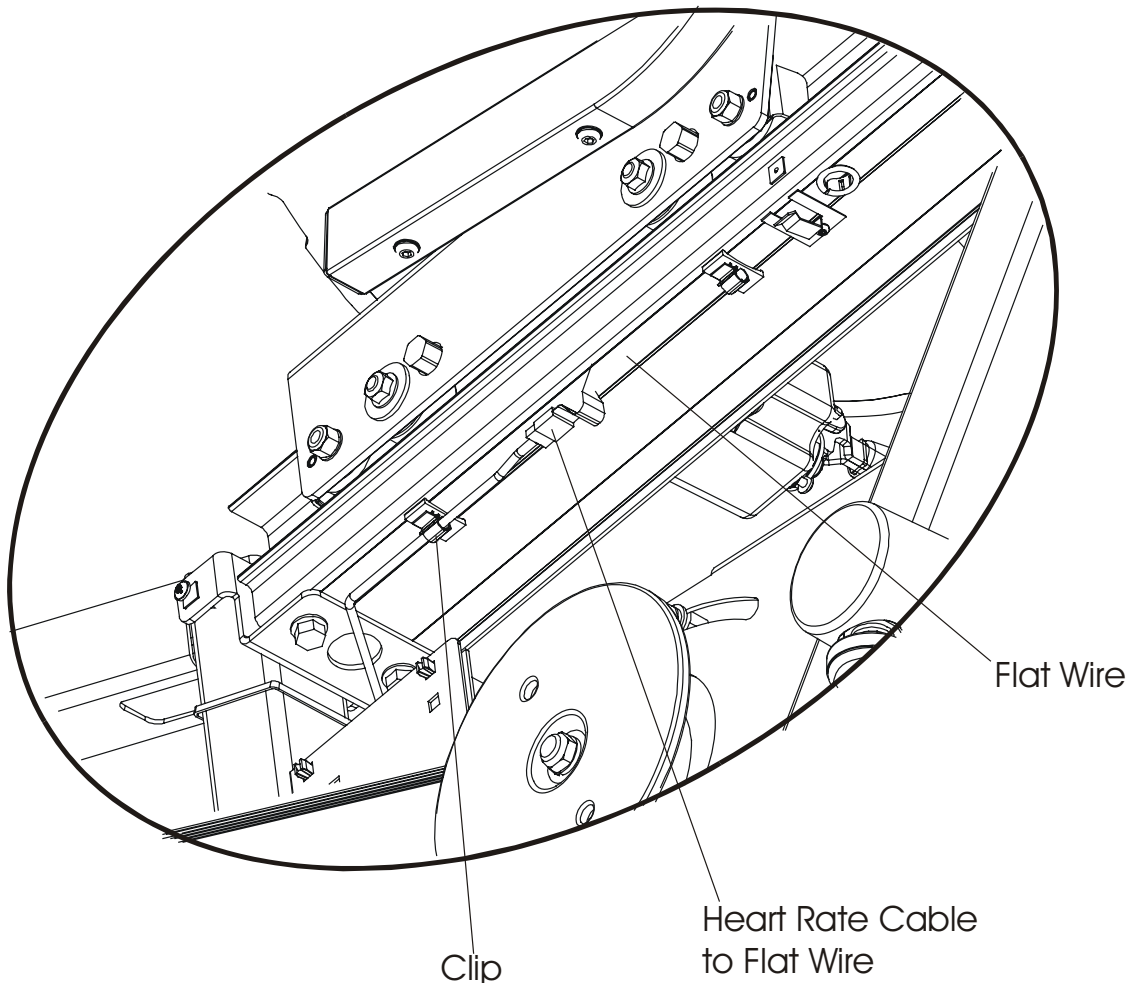
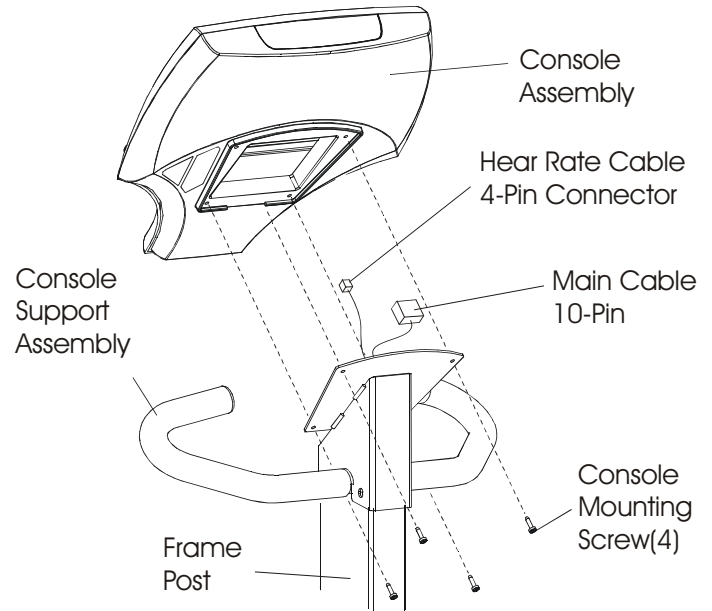

Lifecycle Recumbent Bikes LC95R, LC91R, LC85R, R9, R7, 95Ri, 93Ri, 90R, and 95Re

How To... Replace the Polar Receiver

Special Service Tools: NONE

1. Remove the side shrouds. See "How To..." in this section.
2. Remove the display console from the console support assembly and then, disconnect the main cable and the heart rate cable. See "How To..." in this section.
3. Disconnect the heart rate cable (4-pin connector) from flex cable under the bottom frame.
4. Remove the heart rate cable from the clip along the bottom of the frame.
5. Pull the heart rate cable out from the console post.
6. Split the two halves of the console by removing the screws holding the case halves together.
7. Remove the polar receiver and replace with new one. See illustration.

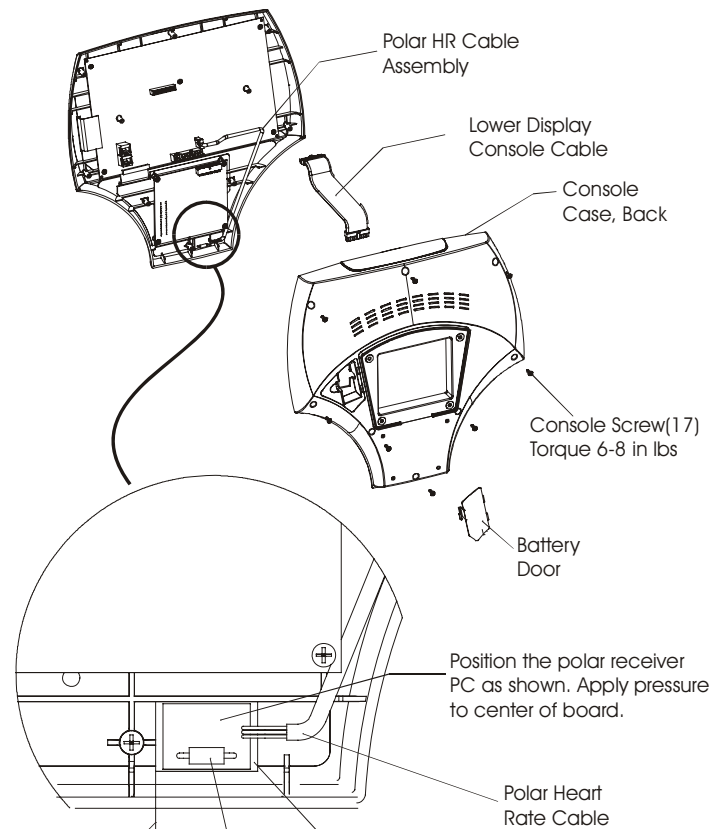
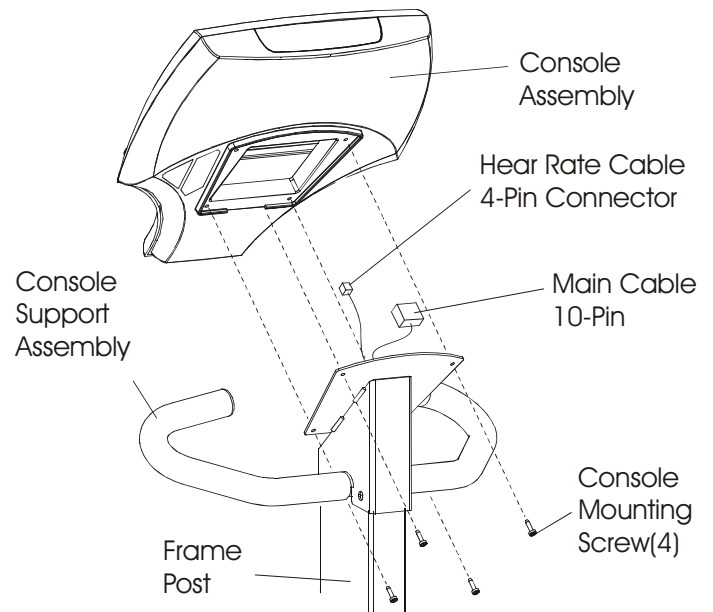

Position the tape edge of the boss gusset and flush to the rib.

Polar Coil

Double-sided adhesive tape

Clean the surface of the console with alcohol before assembling the tape.

Lifecycle Recumbent Bikes LC95R, LC91R, LC85R, R9, R7, 95Ri, 93Ri, 90R, and 95Re How To... Replace the Alternator Cable

Special Service Tools: NONE

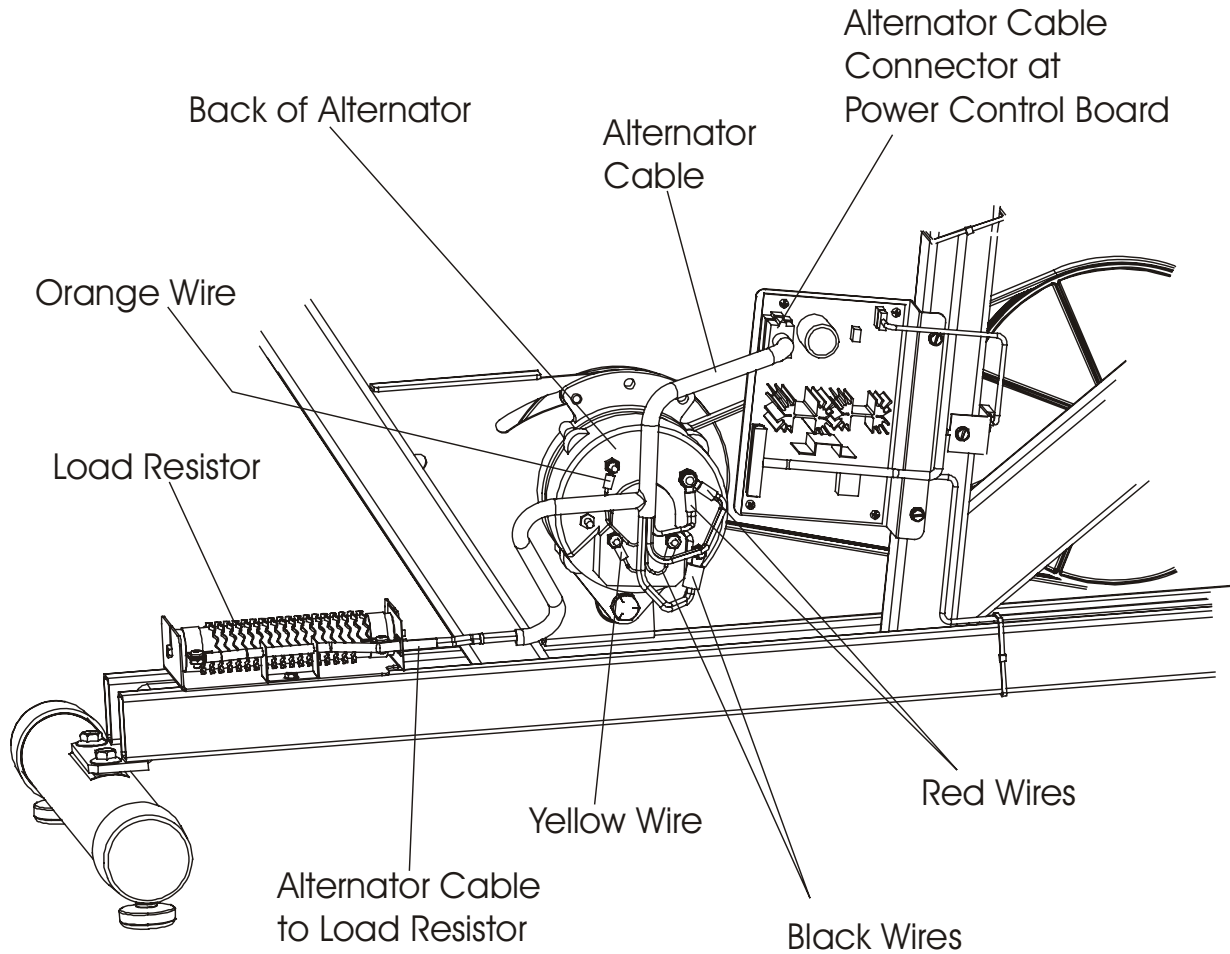

1. Remove the side shrouds. See “How To...” in this section.
2. Disconnect the alternator cable connector from the power control board (PCB), and then remove the other end of the cable from the load resistor.
3. Before disconnecting any wires from the alternator terminals, mark and tag each terminal post to its appropriate wire.
4. With the alternator wires marked and tagged to their corresponding terminals, remove the alternator wires from the back of the alternator.
5. Cut any cable ties, and remove the alternator cable.
6. Install new alternator cable in reverse order.

Lifecycle Recumbent Bikes LC95R, LC91R, LC85R, R9, R7, 95Ri, 93Ri, 90R, and 95Re How To... Replace the Reed Switch and Cable

Special Service Tools: NONE

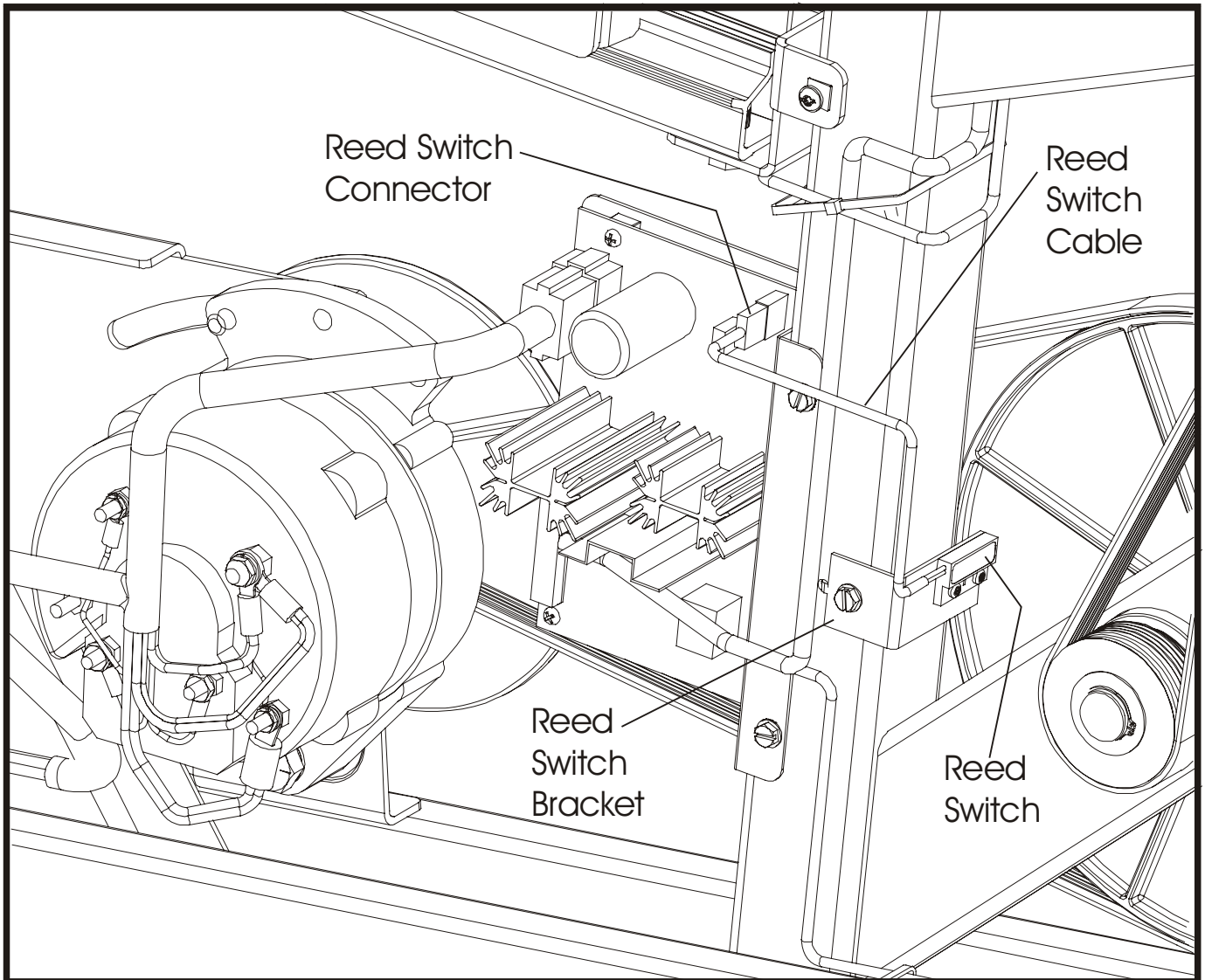

1. Remove the side shrouds. See "How To..." in this section.
2. Disconnect the reed switch connector from the power control board (PCB).
3. To replace just the reed switch cable assembly, remove two screws securing the reed switch it to the bracket.
4. To replace both the reed switch cable assembly and bracket, remove the screw securing the bracket to the frame.
5. Cut any cable ties, and remove the reed switch cable assembly.
6. Install new reed switch cable assembly in reverse order.

Lifecycle Recumbent Bikes LC95R, LC91R, LC85R, R9, R7, 95Ri, 93Ri, 90R, and 95Re How To... Replace the 9-Volt Console Battery (LC8500R and R7)

Special Service Tools: NONE

NOTE: Console removed for clarity.

NOTE: The 9V battery is located in back of the console. To access:

1. Remove the cover at the back of the console to reveal the battery.
2. Unplug the connector, and remove the battery from the console.
3. Install new battery in reverse order.

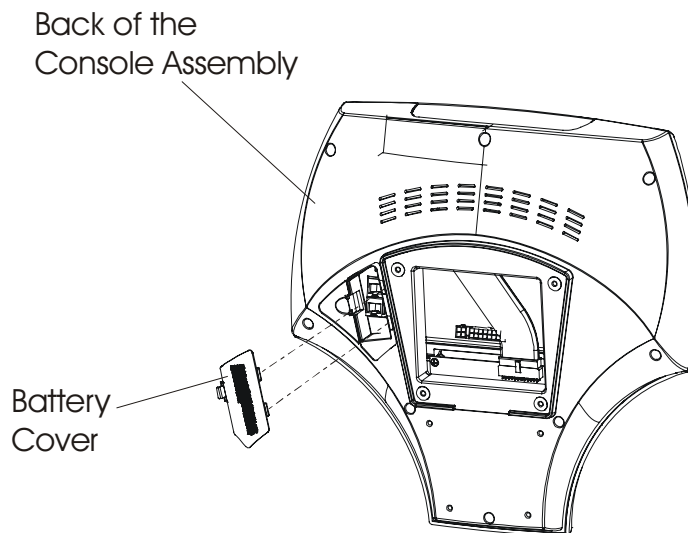

Lifecycle Recumbent Bikes LC95R, LC91R, LC85R, R9, R7, 95Ri, 93Ri, 90R, and 95Re How To... Replace the 6-Volt Battery (LC95R, LC91R and R9)

Special Service Tools: NONE

Note: It is not necessary to remove the shrouds for this procedure unless, the battery bracket requires replacement.

1. Tilt the bike on its side.
2. Remove the two mounting screw securing the battery to the bracket. Remove the battery just enough to access and disconnect the BLACK (neg) wire from the (-) terminal and the RED (pos) wire from the (+) terminal.

Note: If the battery bracket requires replacement, then remove the left or right side shroud and then, remove two mounting screws securing the bracket to the frame.

3. Reconnect the BLACK (neg) wire to the (-) terminal on the battery, and the RED (pos) wire to the (+) terminal, and then secure the battery to the mounting bracket with the two mounting screws.
4. Lift the bike to its upright position.

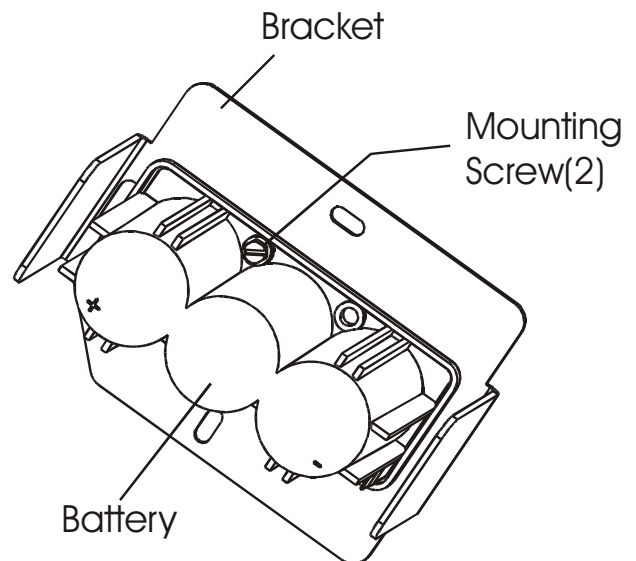
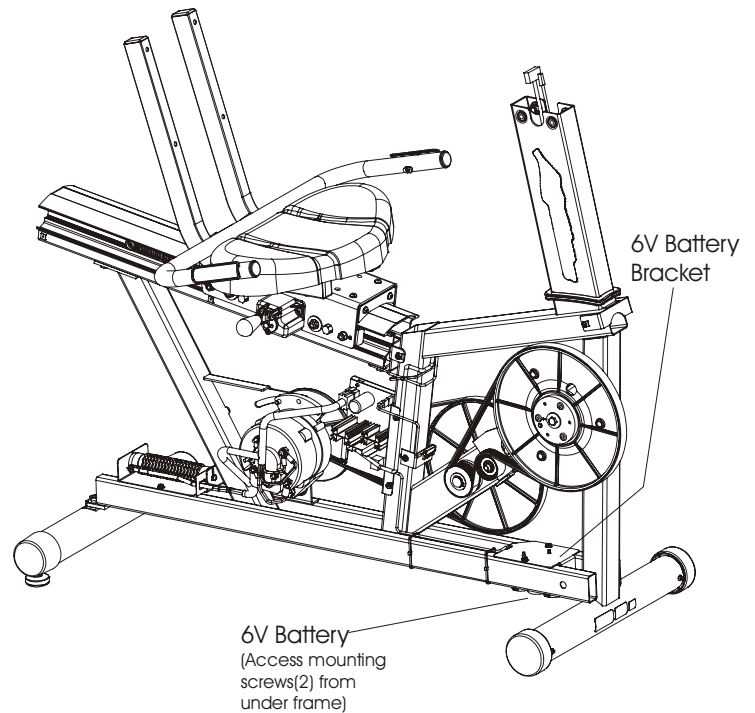

Lifecycle Recumbent Bikes LC95R, LC91R, LC85R, R9, R7, 95Ri, 93Ri, 90R, and 95Re How To... Replace the Display Console and Console Support

Special Service Tools: NONE

1. Remove four mounting screws from the back of the console at the console support.
2. Lift the console up just enough to disconnect the 10-pin main wiring connector, and if equipped, the 4-pin heart rate cable.
3. Remove the console from the console support.
4. Remove four frame post bolts securing the console support.
5. Lift out the console support from the frame post be careful of the wiring.
6. Install console and console support in reverse order of removal.

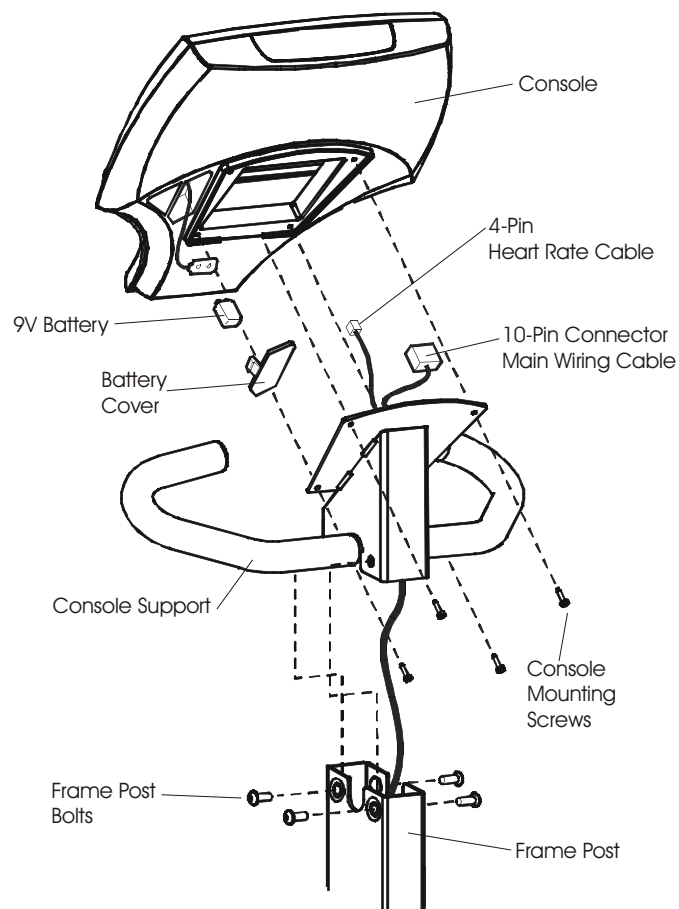

Lifecycle Recumbent Bikes LC95R, LC91R, LC85R, R9, R7, 95Ri, 93Ri, 90R, and 95Re

How To... Replace the Power Control Board

Special Service Tools: NONE

CAUTION! BEFORE REPLACING CIRCUIT BOARD(S), GROUND YOURSELF TO EARTH GROUND USING AN ANTI-STATIC GROUND STRAP.

1. Remove the left side shroud. See "How To..." in this section.
2. Disconnect the alternator cable connector, reed switch cable connect, and battery cable connector from the power control board.

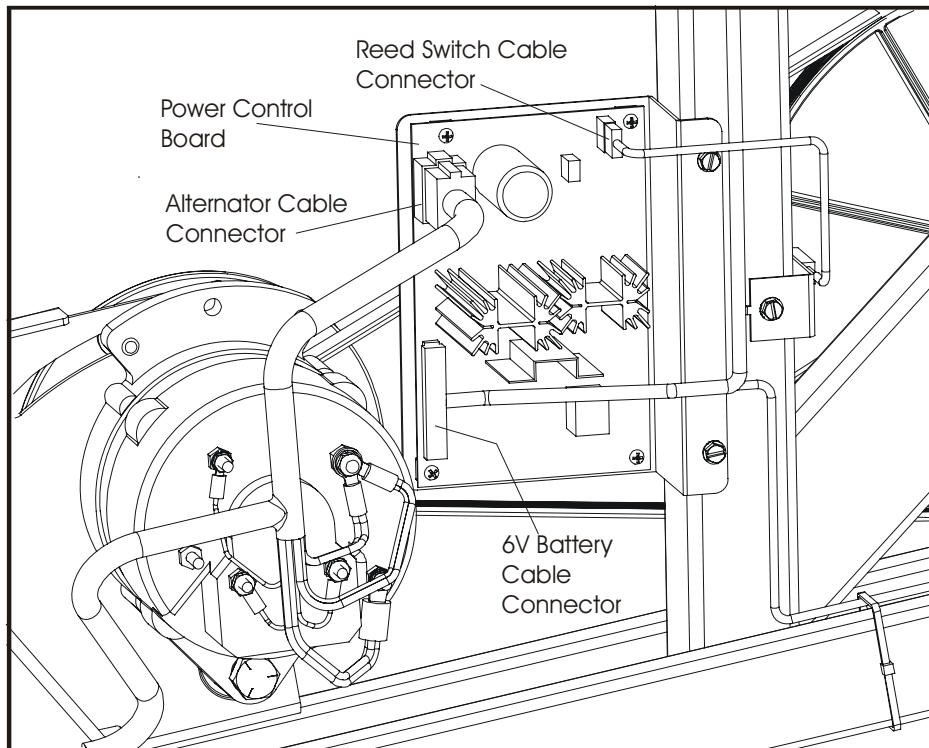

3. Remove four screws securing the PCB to the bracket.
4. If necessary to replace the mounting bracket, remove two screws secured to the frame.
5. Install new PCB board in reverse order.

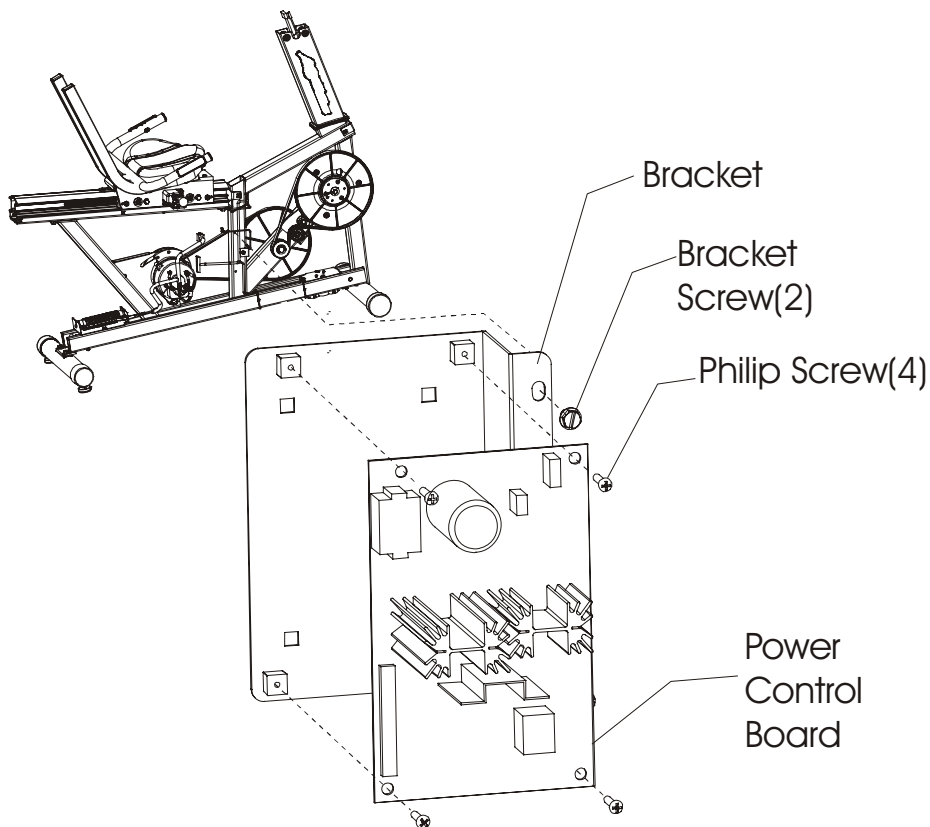

Lifecycle Recumbent Bikes LC95R, LC91R, LC85R, R9, R7, 95Ri, 93Ri, 90R, and 95Re **How To... Replace the Pedal**

Special Service Tools: NONE

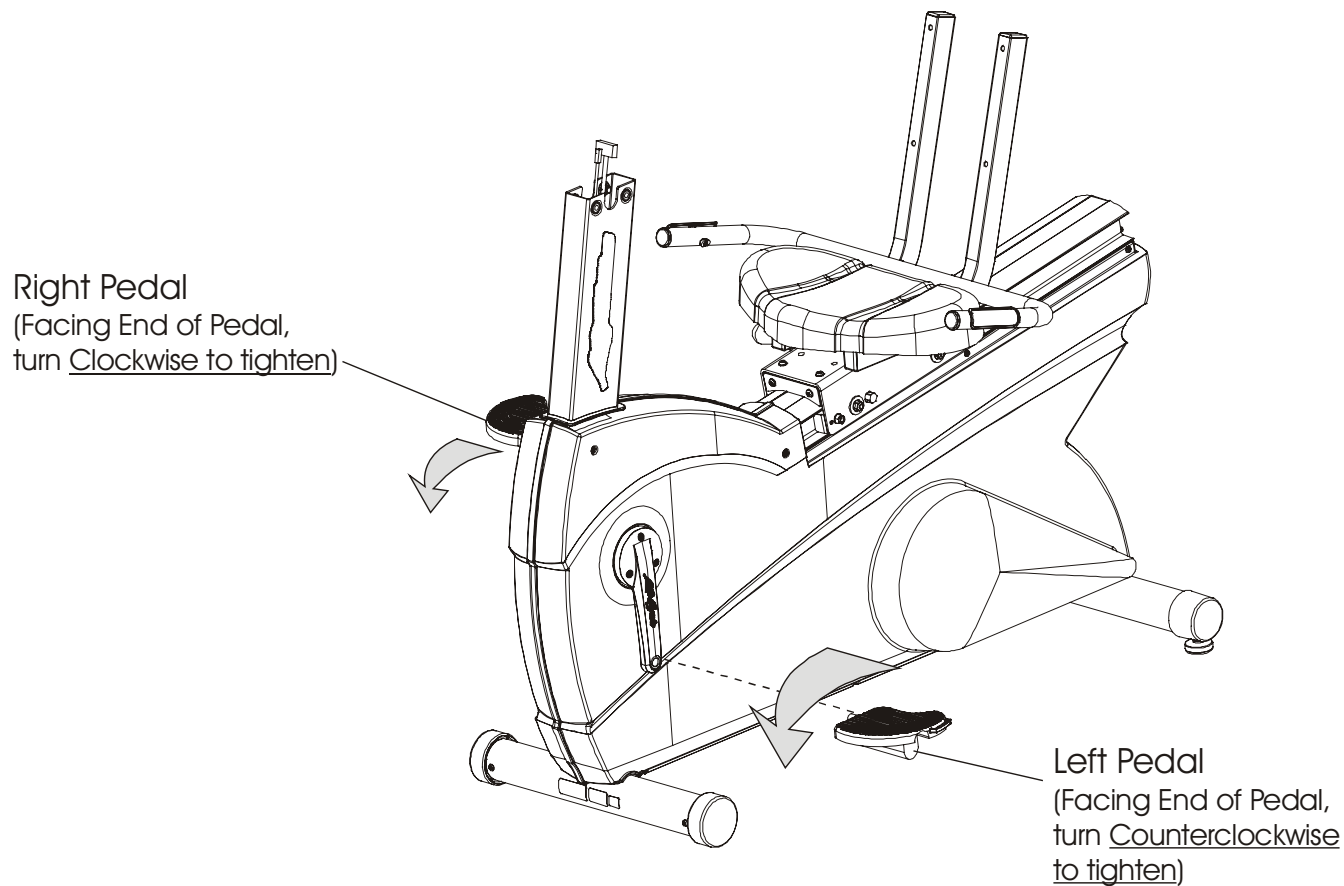

1. Remove the right pedal by turning it counterclockwise.
2. Install the right pedal by turning it clockwise.
3. Remove the left pedal turning it clockwise.
4. Install the left pedal turning it counterclockwise.

Lifecycle Recumbent Bikes LC95R, LC91R, LC85R, R9, R7, 95Ri, 93Ri, 90R, and 95Re How To... Replace the Front Wheel Assembly

Special Service Tools: NONE

1. Remove two TORX screws from each side of the stabilizer bar.
2. Pull the wheel assembly out from the ends of the stabilizer bar.
3. Install new front wheel assemblies in the reverse order.

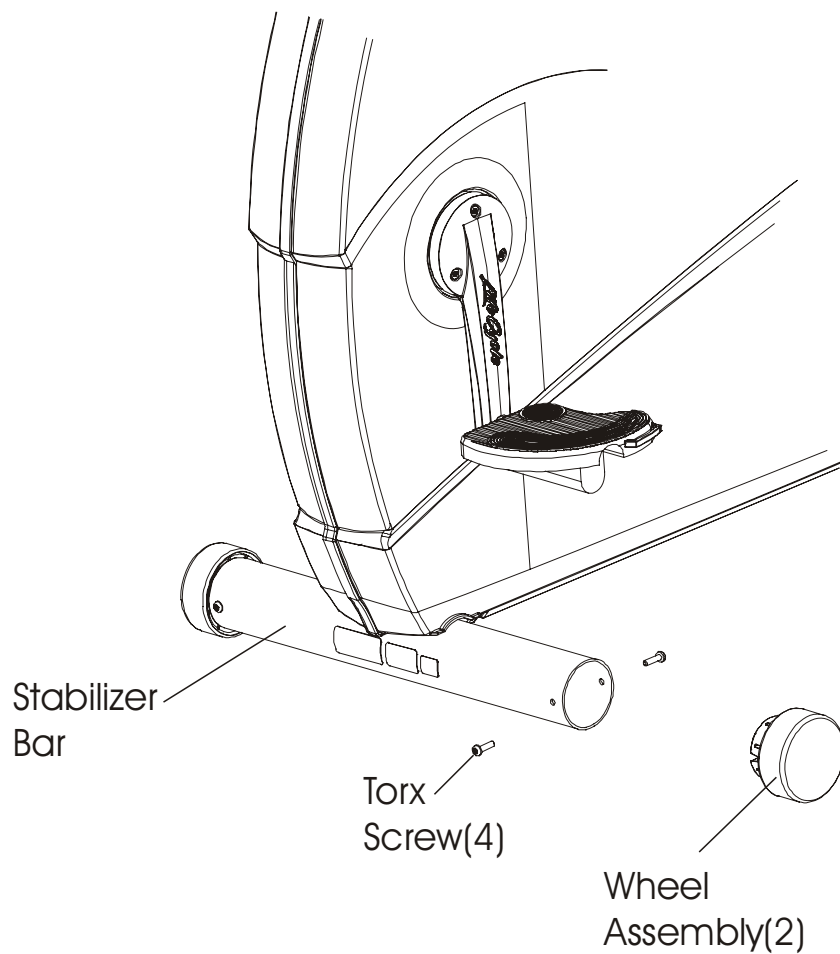

Lifecycle Recumbent Bikes LC95R, LC91R, LC85R, R9, R7, 95Ri, 93Ri, 90R, and 95Re

How To... Replace and Adjust Levelers

Special Service Tools: NONE

Note: The levelers are located under the ends of the rear stabilizer bar. It is very important that the unit be properly leveled before using.

1. Remove the leveler assembly by first loosening the jam nut.
2. Turn the leveler assembly counterclockwise to remove it from the rear stabilizer bar.
3. Install the new leveler, with jam nut, in the reverse order.
4. Adjust the levelers by loosening the jam nut, then turn each leveler clockwise, to move it into the stabilizer, or counterclockwise, to move it out of the stabilizer. Do this for both levelers until the unit is stable and level.

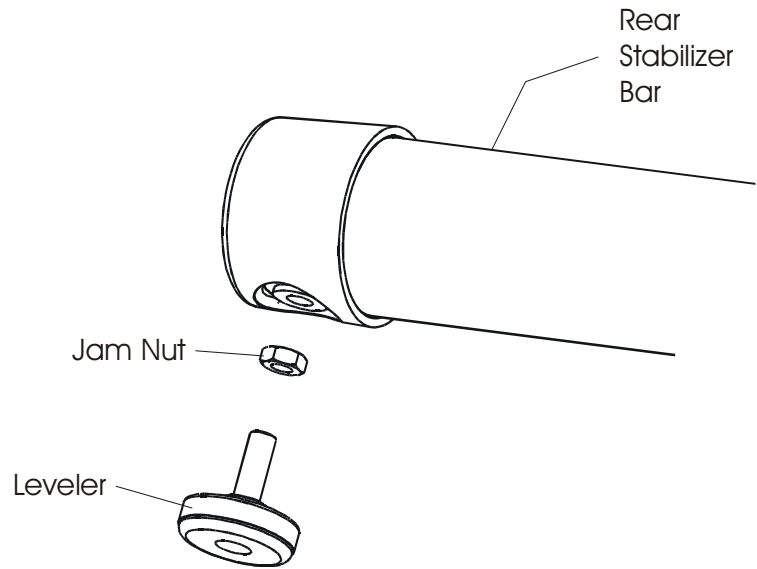

Lifecycle Recumbent Bikes LC95R, LC91R, LC85R, R9, R7, 95Ri, 93Ri, 90R, and 95Re How To... Replace the Resistor Assembly

Special Service Tools: NONE

1. Remove the side shrouds. See "How To..." in this section.
2. Remove two cable mounting screws, and then lift off the cables from the resistor.
3. Remove mounting screws securing the resistor assembly to the frame, and then lift out the resistor assembly from the frame.
4. Install new resistor in reverse order.

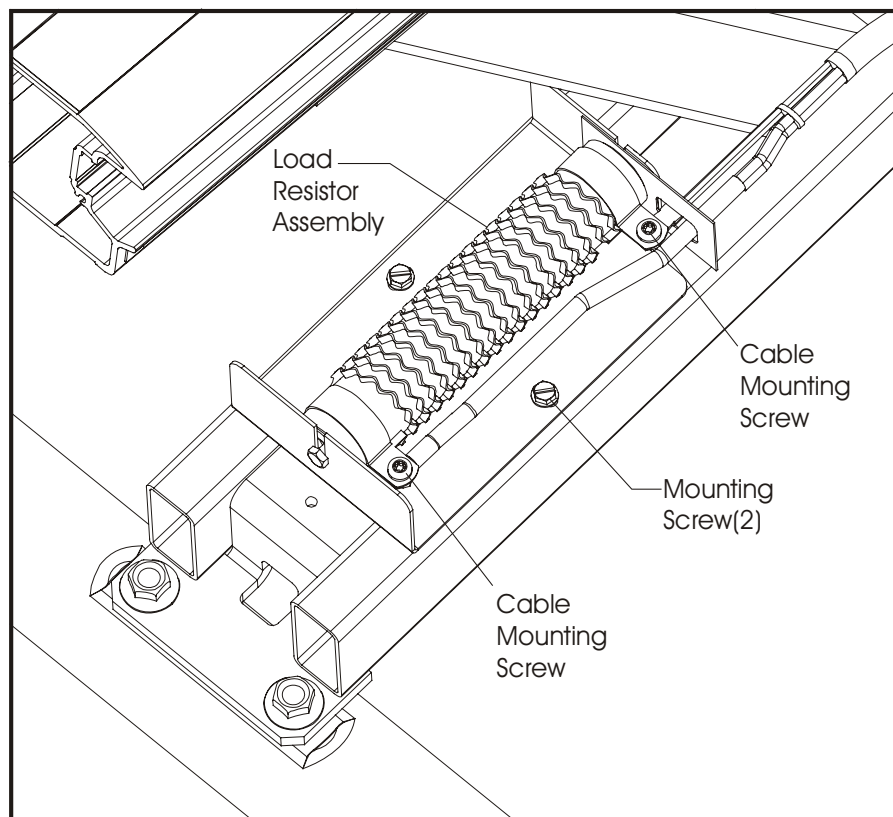

Lifecycle Recumbent Bikes LC95R, LC91R, LC85R, R9, R7, 95Ri, 93Ri, 90R, and 95Re

How To... Replace the Console Circuit Board

Special Service Tools: NONE

CAUTION! BEFORE REPLACING CIRCUIT BOARD(S), GROUND YOURSELF TO EARTH GROUND USING AN ANTI-STATIC GROUND STRAP.

1. Remove the battery cover and battery.
2. Remove the four screws from under the console support.
3. Lift the console up just enough to disconnect the main cable and heart rate cable (if equipped).
4. Remove eight screws from the back of the console and split the halves.
5. Remove the screws securing the console circuit board to the front half of the console, and then remove the console circuit board.
6. Install new circuit board in reverse order of removal.

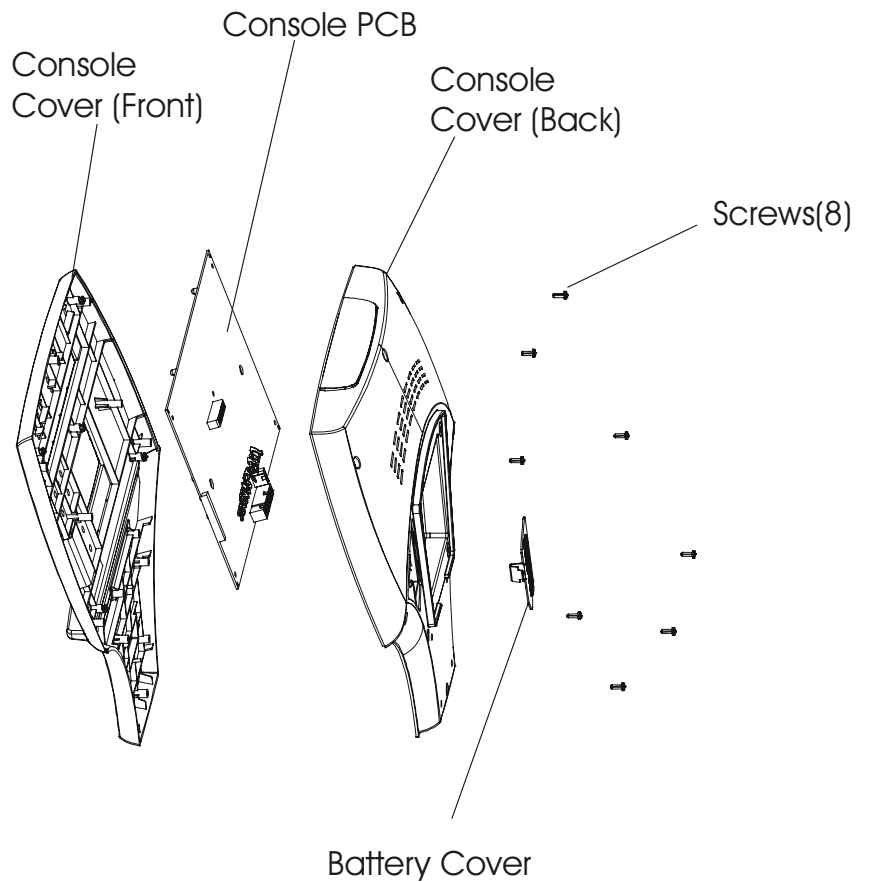

Lifecycle Recumbent Bikes LC95R, LC91R, LC85R, R9, R7, 95Ri, 93Ri, 90R, and 95Re LCD Integrated Console Service Overview

Special Service Tools Required: NONE

CAUTION! BEFORE REPLACING CIRCUIT BOARD(S), GROUND YOURSELF TO EARTH GROUND USING AN ANTI-STATIC GROUND STRAP.

NOTE: The following pages provide service procedures for servicing the LCD Integrated Console. While the Console Housings may differ between the various products, the internal components, which make up the Console, are identical. Use the exploded view below to help identify parts and component location during service.

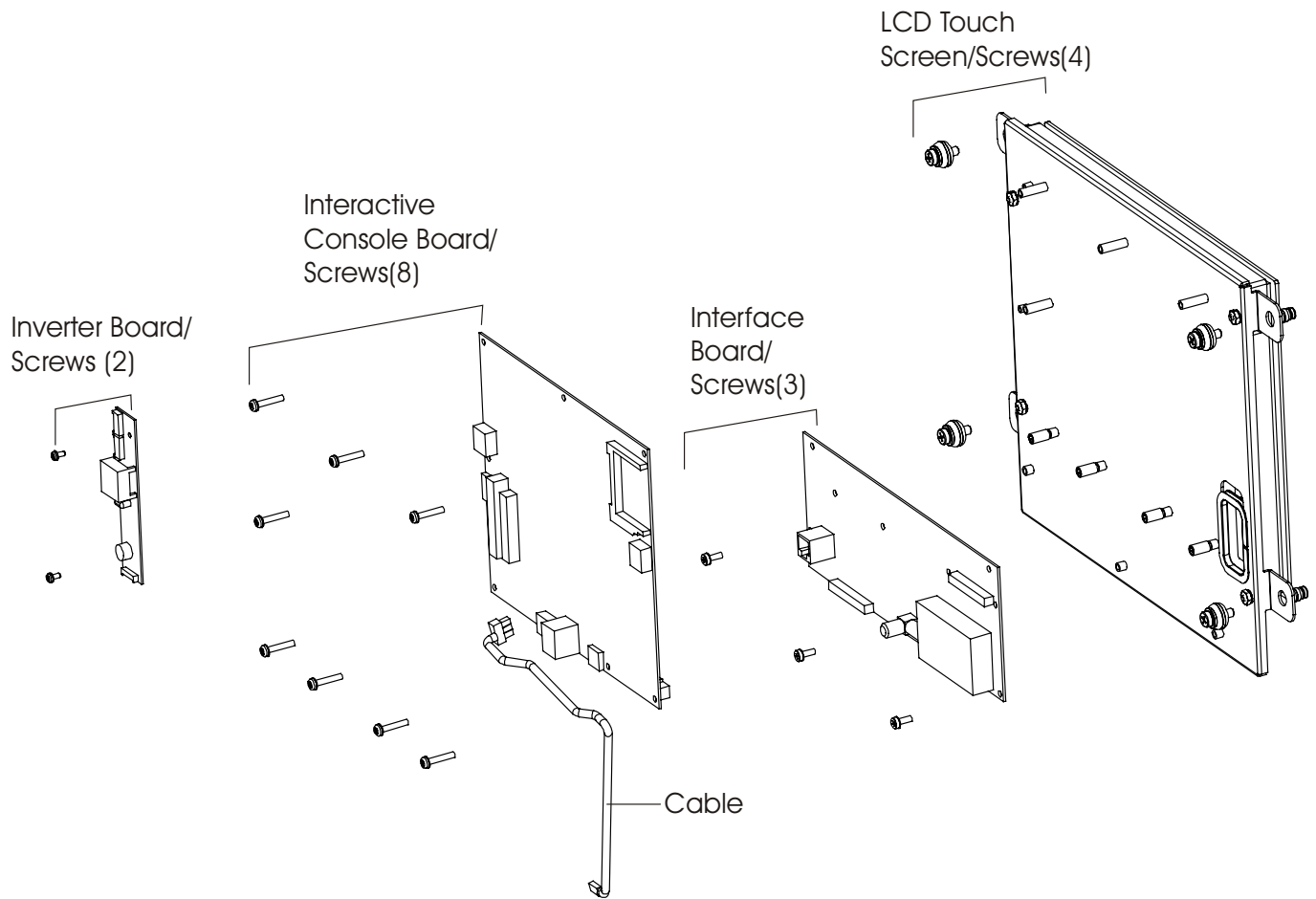

Lifecycle Recumbent Bikes LC95R, LC91R, LC85R, R9, R7, 95Ri, 93Ri, 90R, and 95Re How To... Replace the Headphone Jack

Special Service Tools Required: NONE

CAUTION! BEFORE REPLACING CIRCUIT BOARD(S), GROUND YOURSELF TO EARTH GROUND USING AN ANTI-STATIC GROUND STRAP.

Note: For clarity purposes the Console is shown off the unit. Headphone Jack replacement does not require removal of the Console from the unit.

1. At the bottom of the Console, remove the Phillip Screw securing the Headphone Jack.
2. Remove the Headphone Jack from the Console.
3. Install new Headphone Jack in reverse order.

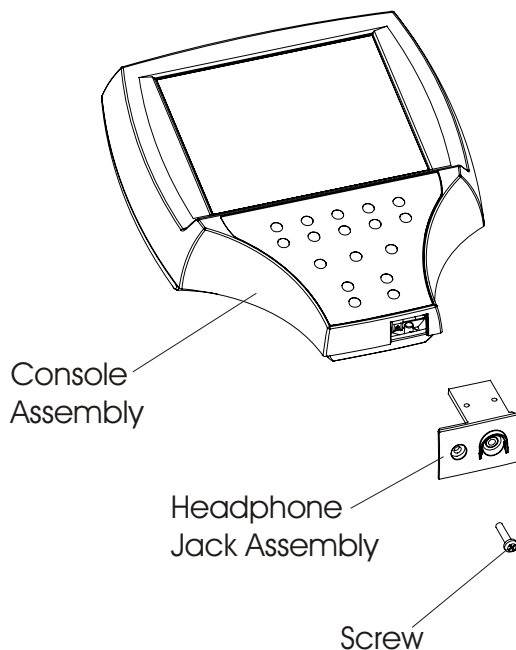

Lifecycle Recumbent Bikes LC95R, LC91R, LC85R, R9, R7, 95Ri, 93Ri, 90R, and 95Re

How To... Replace the Inverter Board

Special Service Tools Required: NONE

CAUTION! BEFORE REPLACING CIRCUIT BOARD(S), GROUND YOURSELF TO EARTH GROUND USING AN ANTI-STATIC GROUND STRAP.

1. Remove console from unit. Refer to Display Console and Accessory Tray Removal.
2. Remove seven screws from the Back Cover and lift the Back Cover off.

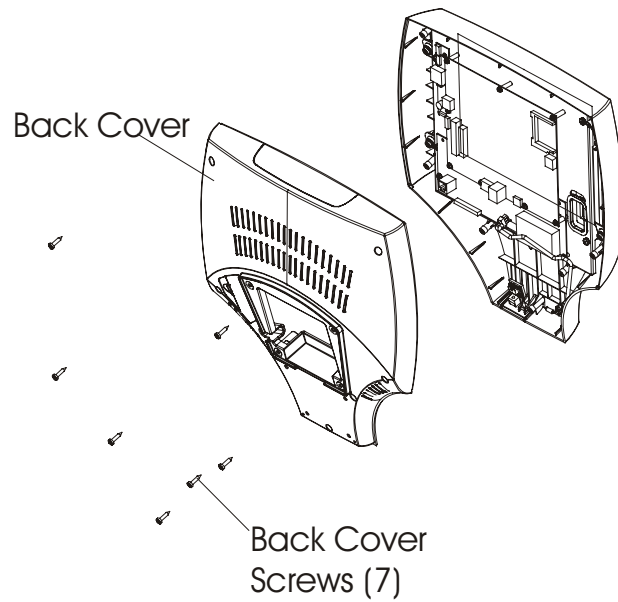

3. Disconnect the Pink/White Power Wire Connectors (2) from the top of the Inverter Board, and the 4-Yellow Wires Connector, which receives Power from the PC to the Inverter, at the bottom of the Inverter Board.
4. Remove two Phillips screws securing the Inverter Board to the back of the LCD Touch Screen and lift it out.
5. Install new Inverter Board in reverse order.

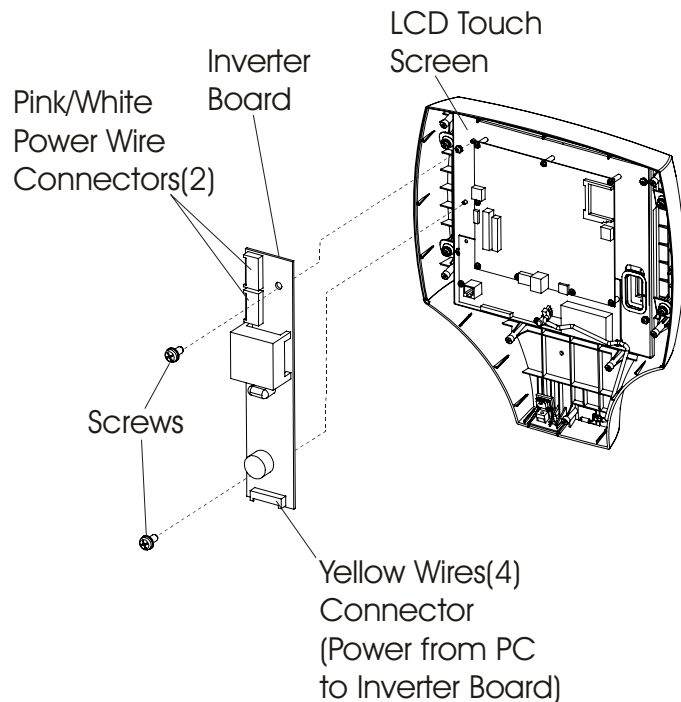

Lifecycle Recumbent Bikes LC95R, LC91R, LC85R, R9, R7, 95Ri, 93Ri, 90R, and 95Re How To... Replace the Single Board Computer

Special Service Tools Required: NONE

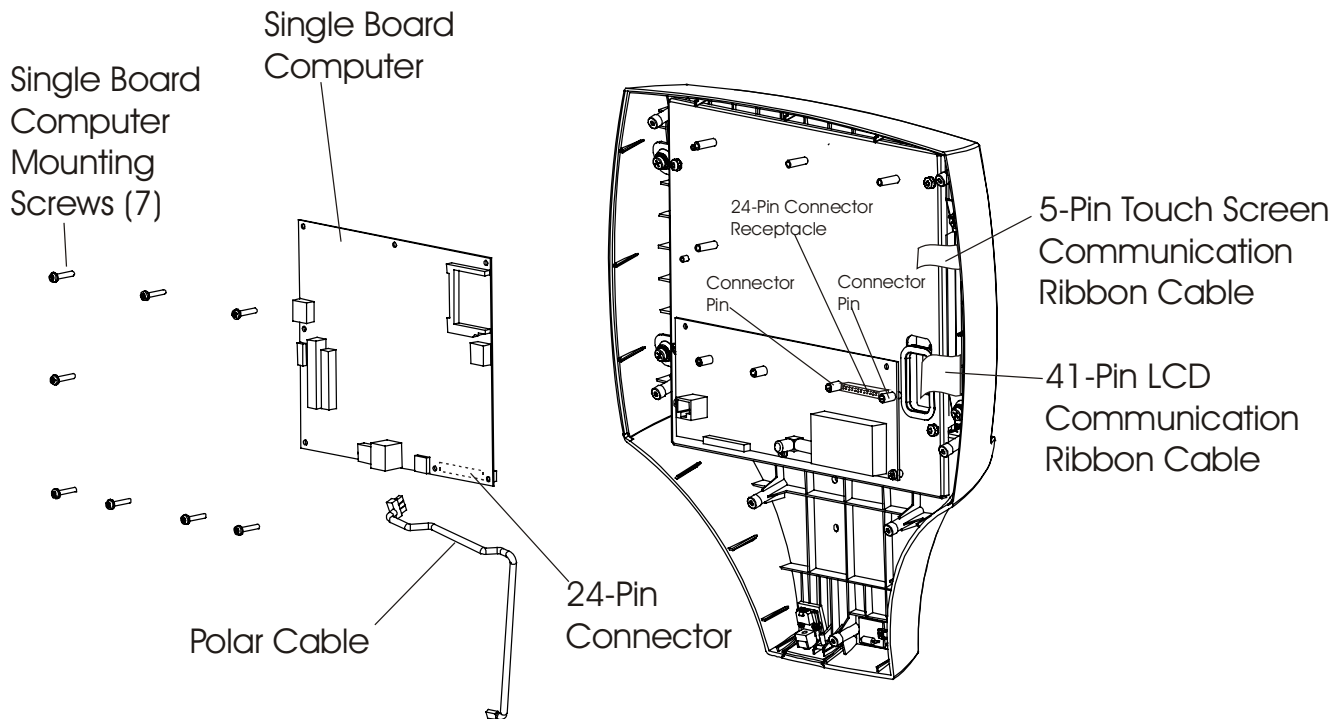

CAUTION! BEFORE REPLACING CIRCUIT BOARD(S), GROUND YOURSELF TO EARTH GROUND USING AN ANTI-STATIC GROUND STRAP.

1. Remove the console from unit refer to Display Console and Accessory Tray Removal.
2. Remove seven screws from the Back Cover.
3. Disconnect all of the cables from the Single Board Computer.
4. Remove seven screws securing the Single Board Computer to the back of the LCD Touch Screen. The Single Board Computer remains engaged into a 24-Pin Connector Receptacle, which is located between two Connector Pins on the Interface Board. Carefully wiggle the Single Board Computer up and out of the Interface Board Connector Receptacle and Connector Pins.
5. Install Board in reverse order. Been careful on connecting the single board computer to the machine interface board.

Lifecycle Recumbent Bikes LC95R, LC91R, LC85R, R9, R7, 95Ri, 93Ri, 90R, and 95Re How To... Replace the Interface Board

Special Service Tools Required: NONE

CAUTION! BEFORE REPLACING CIRCUIT BOARD(S), GROUND YOURSELF TO EARTH GROUND USING AN ANTI-STATIC GROUND STRAP.

1. Remove the console from unit refer to Display Console and Accessory Tray Removal.
2. Remove seven screws from the Back Cover.
3. Remove Single Board Computer
4. Disconnect all Cables from the interface board.
5. Remove 5 screws securing the Interface Board to the mounting bracket.

CAUTION! HIGH VOLTAGE ON INTERFACE BOARD CONNECTORS J2 AND J3.

6. Remove the Interface Board.
7. Install board in reverse order. Be careful on connecting the single board computer to the machine interface board.

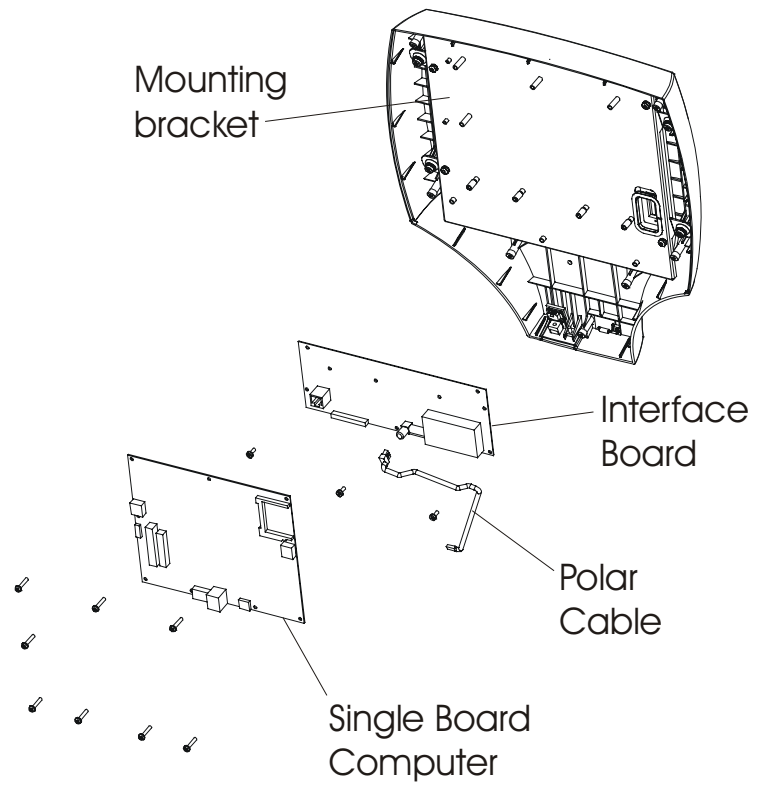

Lifecycle Recumbent Bikes LC95R, LC91R, LC85R, R9, R7, 95Ri, 93Ri, 90R, and 95Re

How To... Replace the Touch Screen Assembly

Special Service Tools Required: NONE

CAUTION! BEFORE REPLACING CIRCUIT BOARD(S), GROUND YOURSELF TO EARTH GROUND USING AN ANTI-STATIC GROUND STRAP.

1. Remove the console from unit refer to Display Console and Accessory Tray Removal.
2. Remove seven screws from the Back Cover.
3. Remove the Single Board Computer. See “How To Replace the Single Board Computer” in this section.
4. Remove the Interface Board. See “How To Replace the Interface Board” in this section.
5. **Remove the Inverter Board. See “How To Replace the Inverter Board” in this section**
6. Remove four screws securing the Touch Screen Bracket Assembly to the bezel Assembly. Remove the Touch Screen Assembly from the Console.
7. Remove the four nuts securing the LCD/touch screen to the bracket then separate the bracket from the assembly.
8. Install new Touch Screen in reverse order.

