

# 1 - Safety

## Safety

Read the Owner's Manual carefully before assembling, servicing or using the VR equipment.

It is the responsibility of the facility owner and/or owner of the equipment to instruct users on proper operation of the equipment and review all labels.

***! WARNING: Serious injury could occur if these safety precautions are not observed:***

- **DO NOT** use the VR equipment if it is not set up and located on a solid level surface.
- Read all cautions/warnings and obtain proper instruction on use of the machines prior to using. Use appropriate positioning, speed and controlled movements.
- Obtain a medical exam prior to beginning an exercise program.
- If at any time during exercise you feel faint, dizzy or experience pain, stop and consult your physician.
- Keep head, limbs, fingers and hair clear of all moving parts.
- **DO NOT** wear loose or dangling clothing while using the VR equipment. Keep away from all moving parts.
- Inspect the VR equipment prior to use. **DO NOT** use if damaged or inoperable.
- **DO NOT** attempt to fix a broken or jammed machines. Notify floor staff.
- Use the machine only for the intended use. Obtain instruction and **DO NOT** modify the machines.
- Children must not be allowed near these machines. Teenagers must be supervised.
- **DO NOT** use if guards are missing or damaged.
- **DO NOT** remove any labeling from the VR equipment. Replace any damaged labels.
- Load plates evenly and carefully to avoid tipping equipment and crushing injuries.
- Use a spotter.
- **DO NOT** use dumbbells or other incremental weights, except those provided by the manufacturer.

## Facility Safety Precautions

- Read the Owner's Manual carefully before assembling, servicing or using the VR equipment.
- Securely anchor each machine to the floor using the anchor holes provided in each machine.

**NOTE:** *Cybox is not responsible for the actual anchoring of equipment. Consult with a professional contractor.*

**NOTE:** *Use fasteners having a minimum of 500 lbs. tensile capacity (3/8" grade 2 bolts or better).*

**NOTE:** *If legs/frame does not contact surface, DO NOT pull down with anchors. Shim any leg or frame not in contact with surface using flat washers.*

- Make sure that all users are properly trained on how to use the VR equipment.
- Make sure there is enough room for safe access and operation of the VR equipment. When the VR equipment is in use, there must be a minimum of at least three feet on all sides for safe access, operation and passage.
- Perform regular maintenance checks on the VR equipment. Also pay close attention to all areas most susceptible to wear.
- Immediately replace worn or damaged components. If unable to immediately replace worn or damaged components then remove from service until the repair is made.
- Use only Cybox supplied components to maintain/repair the VR equipment.
- Keep a repair log of all maintenance activities.
- Inspect all cables and belts and connections prior to use. **DO NOT** use if any components are worn, frayed, or damaged.

**NOTE:** *It is the sole responsibility of the user/owner or facility operator to ensure that regular maintenance is performed.*

### **Warning/Caution Decals**

Warning decals indicate a potentially hazardous situation, which, if not avoided, could result in death or serious injury.

Caution decals indicate a potentially hazardous situation, which, if not avoided, could result in minor or moderate injury.

The warning and caution decals are shown on the following page. The diagrams following the decals show where each decal is located.



See all machines except Row/Rear Delt and Arm Curl, letter A.



See Standing Calf, letter B.

See all machines, letter C.

<p><b>WARNING</b></p>	<p><b>SERIOUS INJURY COULD OCCUR IF THESE PRECAUTIONS ARE NOT OBSERVED</b></p>
<ol style="list-style-type: none"> <li>1. Obtain a medical exam prior to beginning an exercise program.</li> <li>2. Read and understand warning labels and user manual prior to exercising. Obtain instruction prior to use.</li> <li>3. Keep body and clothing free from and clear of all moving parts.</li> <li>4. Inspect machine prior to use. DO NOT use if it appears damaged or inoperable.</li> <li>5. DO NOT attempt to fix a broken or jammed machine. Notify floor staff.</li> </ol>	
<ol style="list-style-type: none"> <li>6. Use the machine only for the intended use. DO NOT modify the machine.</li> <li>7. Be sure that the weight pin is completely inserted. Use only the pin provided by the manufacturer. If unsure seek assistance.</li> <li>8. Never pin the weights in an elevated position. DO NOT use the machine if found in this condition. Seek assistance from floor staff.</li> <li>9. Children must not be allowed near this machine. Teenagers must be supervised.</li> </ol>	
<ol style="list-style-type: none"> <li>10. DO NOT use if guards are missing or damaged.</li> <li>11. DO NOT use dumbbells or other incremental weights, except those provided by the manufacturer.</li> <li>12. Inspect all cables and belts, and connections prior to use. DO NOT use if any components are worn, frayed, or damaged.</li> <li>13. DO NOT REMOVE THIS LABEL. REPLACE IF DAMAGED.</li> </ol> <p>4800-381 C</p>	

## **Regular Maintenance Activities**

Preventative maintenance activities must be performed to maintain normal operation of your VR equipment. Keeping a log sheet of all maintenance actions will assist you in staying current with all preventative maintenance activities. The preventative maintenance actions are described in detail in Chapter 7. Briefly, they include:

### **Daily**

1. Clean upholstery.

### **Weekly**

1. Inspect all nuts and bolts for looseness. Tighten as required.
2. Inspect all cables for damage or wear (see Chapter 7). **Immediately discontinue use if a cable is worn or damaged.**
3. Check for worn handles, worn snap links, and worn warning labeling. Replace all worn parts immediately.
4. Inspect weight stacks for proper alignment and operation. Correct all improper alignment and operation issues immediately.
5. Lubricate guide rods using automotive engine oil only.

### **Yearly**

1. Replace all cables at least annually.

### **As Required**

1. Inspect grips and replace as necessary.

## **Using Proper Form**

Before working out, read and understand the training suggestions listed in Chapter 3. See Chapter 4 for proper form during exercise.

## 4 - Assembly

### Tools Required

- External snap ring pliers
- Hammer
- Medium weight automotive engine oil

### Installing Weight Stacks

**! WARNING:** Use extreme caution when installing the weight stacks, failure to do so could result in injury.

**NOTE:** Two people will be required to perform this procedure.

**NOTE:** Read and understand all instructions thoroughly before installing weight stacks.

1. Place machine in desired location.
2. Remove all banding and shipping supports.
3. Using an external snap ring pliers, remove the upper snap ring from one of the guide rods and carefully lower the guide rod. See Figure 1.

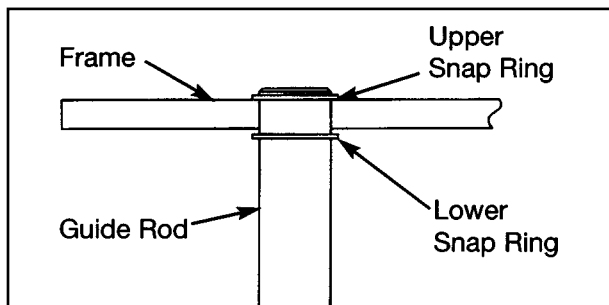

Figure 1

4. Remove lower snap ring from the guide rod. Repeat steps 3 and 4 to remove both snap rings from other guide rod.
5. Lean guide rods in the direction that will provide the most room for installing weight plates (direction may vary, depending upon machine).
6. Slide top weight up and out of machine and carefully set it aside.
7. Wipe guide rods clean over entire length. Lubricate with light coating of medium weight automotive engine oil.
8. Carefully install weight plates one at a time.

9. Slide top weight onto guide rods.
10. Place lower snap ring onto guide rod (about 3" from top end of guide rod).
11. Raise guide rod up through mounting hole and install the upper snap ring. Lower guide rod and secure lower snap ring. Repeat steps 10 and 11 for the other guide rod.
12. Verify that the ring securing the weight selector pin to the machine is inserted around the top weight connector.
13. Insert cable end connector into top weight and align cable fitting opening with opening in top weight for proper cable tension. **NOTE:** *Top weight should just rest on the second weight plate.*
14. Using a hammer, drive roll pin through top weight cable connector holes and cable fitting. Assure pin is flush with top weight connector. See Figure 2.

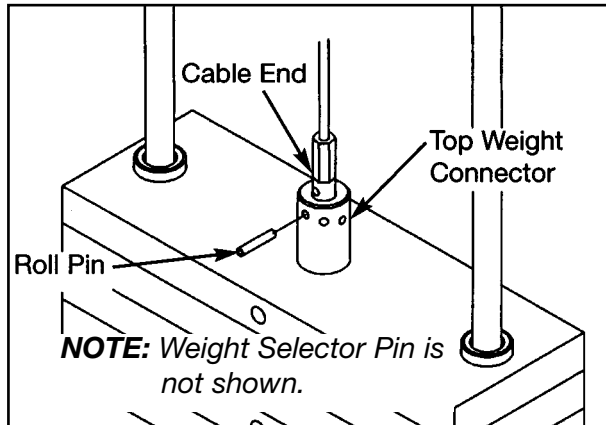

Figure 2

15. Insert weight stack selector pin into each plate to verify proper alignment.
16. Verify proper cable tension.
  - A. If there is too much tension then the top weight plate will not properly rest on second weight and the weight selector pin may be difficult to insert into weight plates.
  - B. Too much slack is indicated if top weight plate does not lift immediately after raising top weight plate (in normal fashion). A slight slack in cable is ok.

17. Place decals on weight plates according to steps listed below and Figures 3 and 4.
- A. Slowly and carefully peel off back side of decal. **NOTE:** *When peeling off back cover, make sure that the decals remain attached to the front sticker.*
  - B. Align holes in decal with appropriate holes in weight stack. **NOTE:** *Do not allow the adhesive to touch weight stack at this time.*
  - C. Insert a guide pin through each hole of the template. **NOTE:** *A guide pin can be anything that fits through the weight stack hole, such as a weight stack selector pin.*
  - D. Carefully align decal and rub it onto weight plates.
  - E. Carefully remove front side, leaving decals adhering to weight plates. See Figure 4.

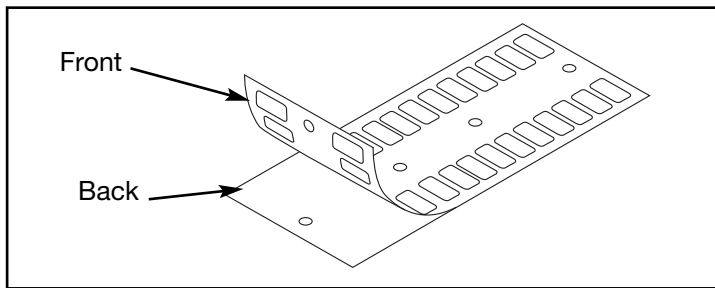

Figure 3

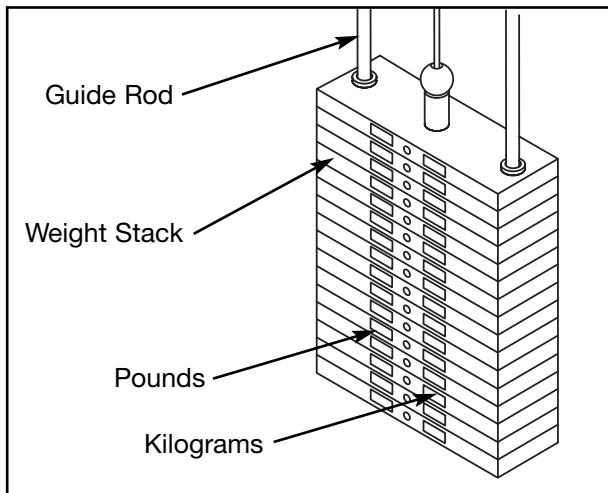

Figure 4

18. Place half weight on weight peg.

**NOTE:** *It is important that you perform regular inspection and maintenance activities on your equipment. See Chapter 7.*

**Cyber VR Owner's Manual**

**Note:** Refer to each individual machine for standard (Heavy Stack) configuration.  
Refer below if you have a Light Stack configuration.

**LIGHT VR STACK CONFIGURATION**

ITEM	QTY	PART NO.	DESCRIPTION
1	2	4700-019	Flange Bearing .62 x .95 x 1.50 L
2	2	BR030206	Retaining Ring
3	4	HS760106	Flat Washer 1.75 X .68 8 X .140 T
4	2	PR060005	Weight Bumper

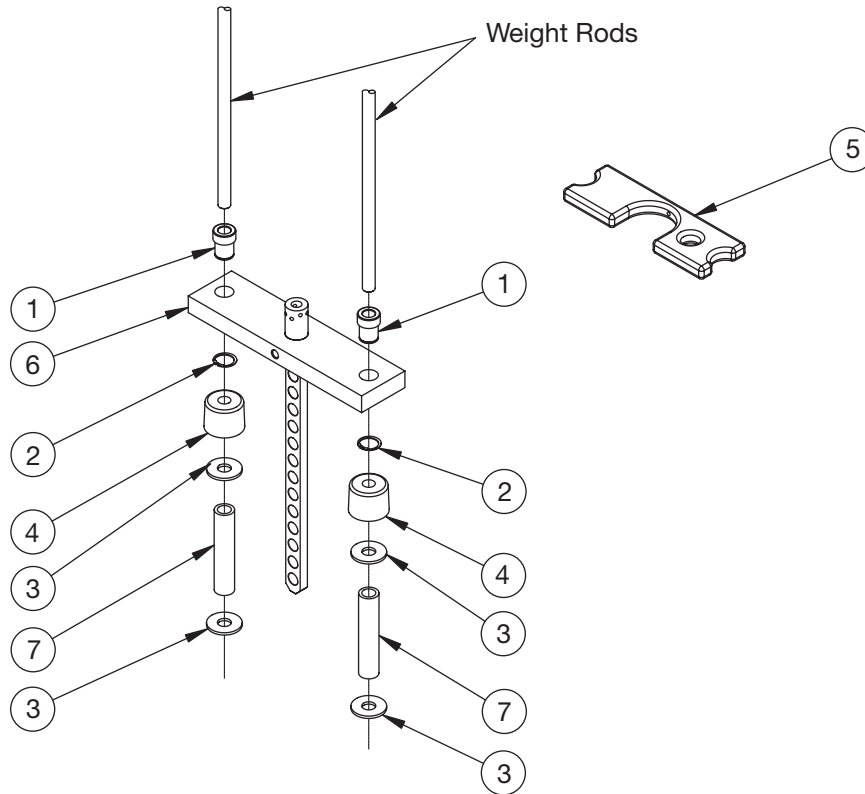

**Note:** #8 is not shown.

Machine Name	Model Number	Balloon #5 Half Weight QTY 1	Balloon #6 Top Weight QTY 1	Balloon #7 Spacer QTY 2	Balloon #8 Weight Decal QTY 1
Chest Press	4800	4301C096	4700C070	4800-329	4800-557
Overhead Press	4805	4301C096	4700C073	4800-330	4800-557
Lat Pulldown	4810	C-ZA000200	4800-252	4800-331	4800-554
Row/Rear Delt	4815	C-ZA000200	4800-252	4800-328	4800-554
Arm Curl	4820	4301C096	4700C073	4800-327	4800-557
Arm Extension	4825	4301C096	4700C073	4800-327	4800-557
Fly	4840	C-ZA000200	4800-260	4800-327	4800-554
Leg Extension	4850	4301C096	4700C070	4800-326	4800-557
Prone Leg Curl	4855	4301C096	4700C073	4800-327	4800-557
Seated Leg Press	4860	C-ZA000200	4800-261	4800-331	4800-556
Rotary Hip	4865	4301C096	4700C073	4800-330	4800-557
Standing Calf	4875	C-ZA000201	4800-253	4800-329	4800-556
Glute	4880	4301C096	4700C073	4800-327	4800-557



## 5 - Maintenance

All preventive maintenance activities must be performed on a regular basis. Performing routine preventive maintenance actions can aid in providing safe, trouble-free operation of your Cybex VR equipment.

**NOTE:** *Cybex is not responsible for performing regular inspection and maintenance actions for your machines. Instruct all personnel in equipment inspection and maintenance actions and also in accident reporting/recording. Cybex phone representatives are available to answer any questions or concerns that you may have.*



**Cybex will void warranty if non-Cybex replacement parts are used.**

### **Daily Procedures**

1. **Upholstery** - Wipe down all upholstery as per the recommendations listed below for light soiling and more difficult stains.

#### *Light Soiling*

- A solution of 10% household liquid dish soap with warm water applied with a soft damp cloth.
- If necessary, a solution of liquid cleanser and water applied with a soft bristle brush. Wipe away the residue with a water dampened cloth.

*More Difficult Stains*

- Dampen a soft white cloth with a solution of household bleach (sodium hypochlorite), 10% bleach, 90% water. Rub gently. Rinse with a water dampened cloth to remove bleach concentration.
- The same procedure can be used with full strength household bleach, if necessary.
- Allow bleach to puddle on the affected area or apply with a soaked cloth for approximately 30 minutes. Rinse with a water dampened cloth to remove any remaining bleach concentration.

*Alternative Method for Difficult Stains*

- Dampen a soft white cloth with rubbing alcohol and rub gently. Rinse with a water dampened cloth to remove any remaining rubbing alcohol concentration.

**NOTE:** *To restore luster, a light coat of spray furniture wax can be used. Apply for 30 seconds and follow with a light buffing using a clean white cloth.*

***Please Review Carefully***

When using strong cleaning agents such as rubbing alcohol or bleach, it is advisable to first test in an inconspicuous area. Other cleaning agents may contain harsh or unknown solvents and are subject to formula changes by the product manufacturer without notice. Should you desire to use other cleaning agents, carefully try them in an inconspicuous area to determine potential damage to the material. Never use harsh solvents or cleaners which are intended for industrial applications. To clean stained or soiled areas, a soft white cloth is recommended. Avoid use of paper towels.

Cleaning products may be harmful/irritating to your skin, eyes, etc. Use protective gloves and eye protection. Do not inhale or swallow any cleaning product. Protect surrounding area/clothing from exposure. Use in a well ventilated area. Follow all product manufacturer's warnings. Cybex and its vendors cannot be held responsible for damage or injuries resulting from the use or misuse of cleaning products.

- 2. Frames** - Wipe down all frames using a mild solution of warm water and car wash soap. Be sure to dry thoroughly. **AVOID** acid or chlorine based cleaners and also cleaners containing abrasives as these could scratch or damage the equipment.
- 3. Chrome** - Clean chrome tubes, first using chrome polish and then using a car wax seal. Neutral cleaners with a pH between 5.5 and 8.5 are recommended. Be sure to dry thoroughly. **AVOID** acid or chlorine based cleaners and also cleaners containing abrasives as these could scratch or damage the equipment.

**Weekly Procedures**

1. Inspect all nuts and bolts for looseness. Tighten as required.
2. Inspect all cables for wear or damage and proper tension. When inspecting cables, run your fingers on the cable, paying particular attention to bends in the cable and attachment points.

***! WARNING: Replace all worn cables immediately. The following conditions may indicate a worn cable:***

- A tear or crack in the cable sheath that exposes the cable. See Figure 1.

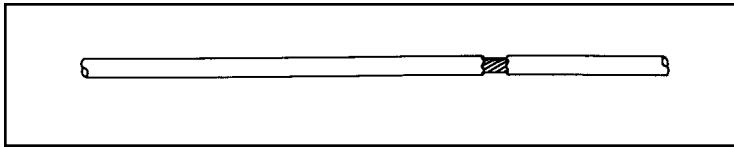

Figure 1

- A kink in the cable. See Figure 2.

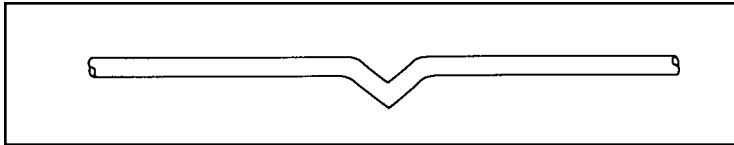

Figure 2

- A curled sheath. See Figure 3.

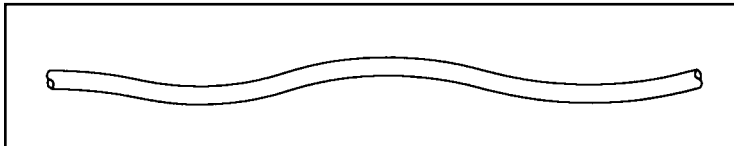

Figure 3

- “Necking”, a stretched cable sheath. See Figure 4.

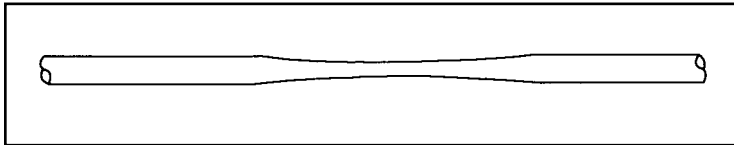

Figure 4

3. Inspect bars and handles for wear, paying particular attention to tab area connecting points.

**Replace all worn handles immediately.**

***! CAUTION: Replace all worn handles immediately. Do not use if less than 1/8" of material remains to the edge. See Figure 5.***

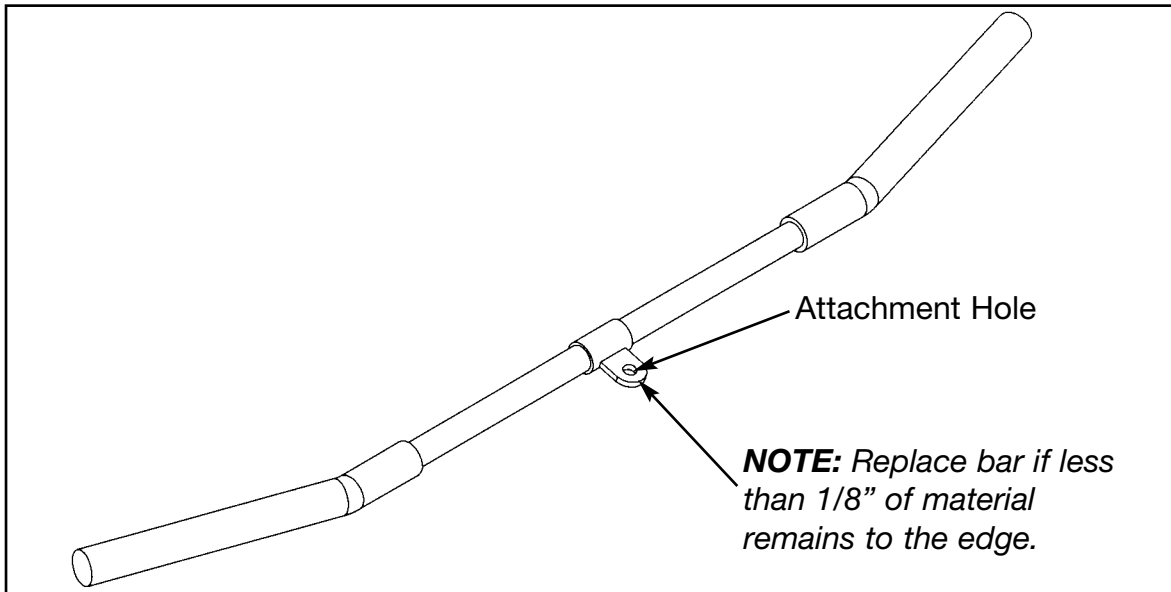

Figure 5

4. Inspect snap links for proper latching (indicates wear).

**Replace all worn snap links immediately.**

5. Inspect all labeling for readability. This includes instructional placards, warning and caution decals.

**Replace all warning labeling immediately.**

6. Inspect all weight stacks for proper alignment and operation.

***NOTE: Correct all improper alignment and operation issues immediately.***

7. Wipe *Weight Stack Guide Rods* and *Leg Press Linear bearings* clean over entire length. Lubricate with a light coat of medium weight automotive engine oil.

### **Yearly Procedures**

Replace all cables at least annually.

### **"As Required" Procedures**

1. Inspect grips and replace as necessary.
2. Clean *Range Limiting Device* so that the cam tracks are wiped clean and lightly lubricated with a Teflon base spray lubricant (Superlube®).
3. Remove *Cable End Bearings* and lubricate thoroughly with a medium-weight automotive engine oil. To lubricate: Loosen rod end bearing jam nut with a 9/16" wrench. Using a 7/32" Allen wrench, remove the socket head cap screw (SHCS) and rod end bearing from unit. Coat bearing thoroughly with oil inside and out and reattach to unit.

## Cables Adjustments

Three types of cable tension adjustment are used on Cybox Strength Systems:

1. **Jam Nut Adjustment** - This type uses a jam nut and a tension adjustment nut at the cable cam end as the primary adjustment. The other end of the cable usually contains a roll pin adjustment. See Figures 6 and 8.

2. **Rod End Adjustment** - This type of adjustment contains a socket head cap screw (SHCS) securing a cable rod end bearing to the machine. Primary adjustment is by returning cable usually contains a roll pin cable adjustment. See Figures 7 and 8.

3. **Roll Pin Adjustment** - This type of adjustment utilizes a roll pin and series of holes in the weight stack top plate connector. See Figure 8.

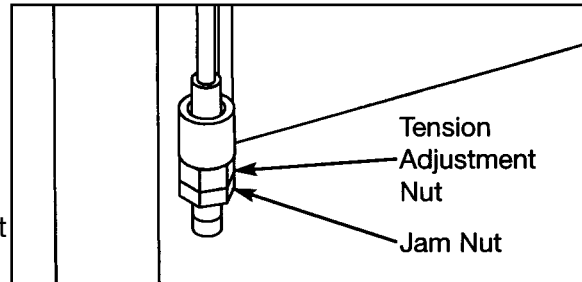

Figure 6

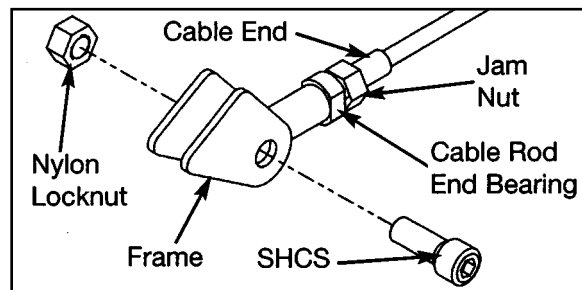

Figure 7

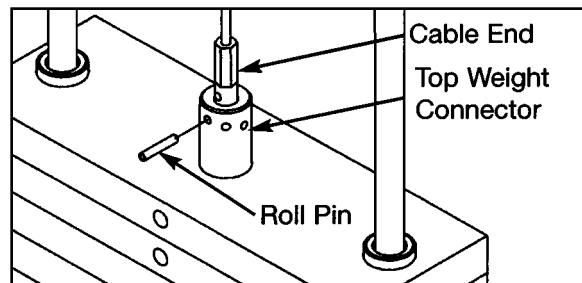
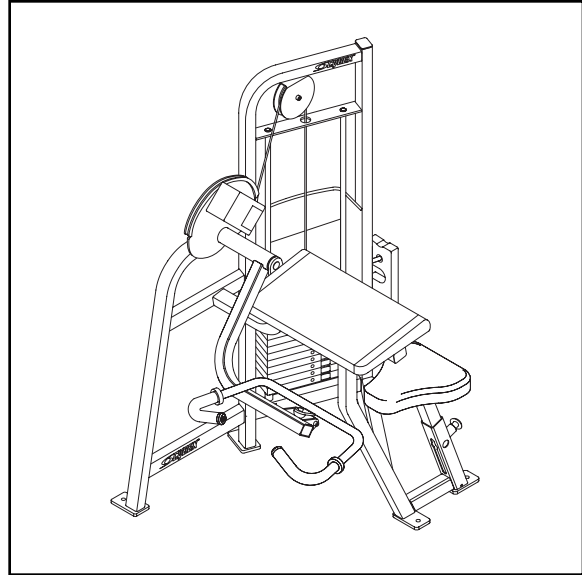

Figure 8

### Arm Curl - 4820

- **Axis Alignment** - The axis or pivot point of the machine is properly positioned to allow alignment with the elbow joints.
- **Accommodating Grip** - The handles are angled slightly for proper wrist/grip alignment in full supination specifically for biceps training.
- **Variable Resistance** - The cam provides increased resistance at the point in the range where force output of the biceps is the greatest.



### The Biceps

- **Elbow Flexion** - The triceps brachii is responsible for extension of the elbow joint as well as supination of the radioulnar joint. The biceps are most effective at performing elbow flexion when the position of full supination is maintained throughout the entire range of motion. The biceps also cross the shoulder joint, although it is more effective at stabilizing the shoulder than moving it. It should be noted that any movement of the shoulder joint during resisted elbow flexion usually decreases the effectiveness of the exercise by allowing unresisted change in the biceps length.
- **Range of Motion** - Normal elbow motion is 0 to 150 degrees. During isolated biceps work the range of motion is limited by the user's ability to control the biceps in flexion concentrically and extension eccentrically.

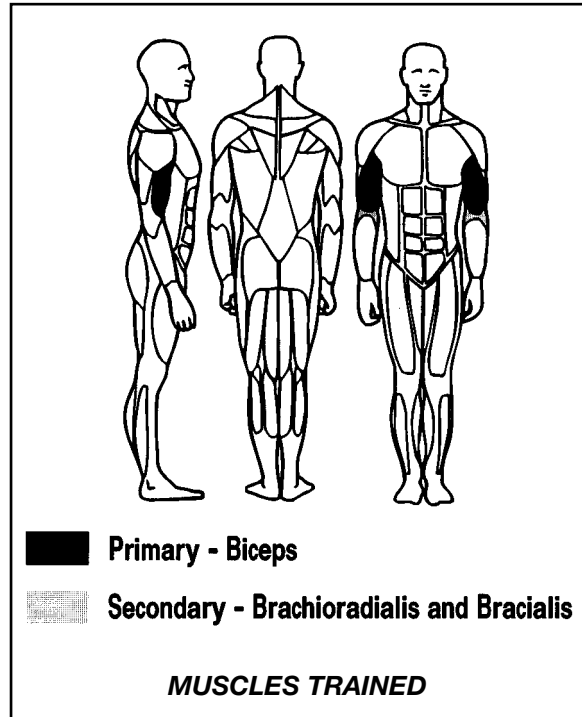

- **Associated Muscles** - The brachialis and brachioradialis are both prime movers for elbow flexion. The brachialis is equally effective in all radioulnar positions, however, it is emphasized alone when pronation is maintained during elbow flexion due to the decreased effectiveness of the biceps and brachioradialis in this position. The brachioradialis is emphasized when the neutral (hammer) position is maintained.

### ***The Positioning***

- Adjust the seat to allow the upper arm to rest on the pad.
- Check the weight to insure that the appropriate resistance has been selected. Body position and control of the motion should never be compromised by excessive weight.
- Grip the handles.
- Sit with the spine erect and scapula retracted (shoulder blades pinched back and together).
- Position the arms parallel to each other.
- Note the pivot point at the right edge of the arm pad. Position the elbows in line with the pivot point.
- By depressing the scapula (lowering the shoulders), press the upper arms firmly into the pad and elevate the elbows slightly.

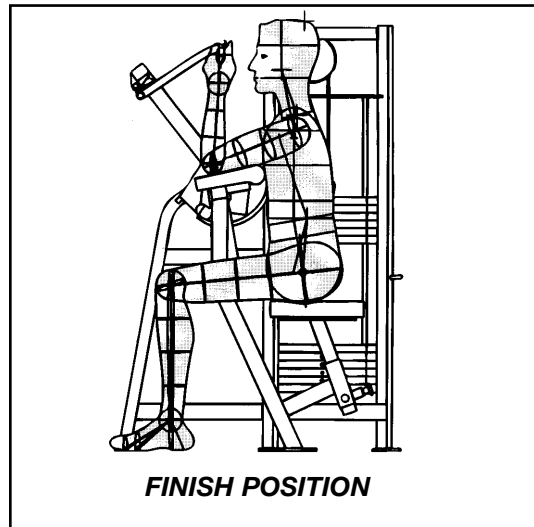
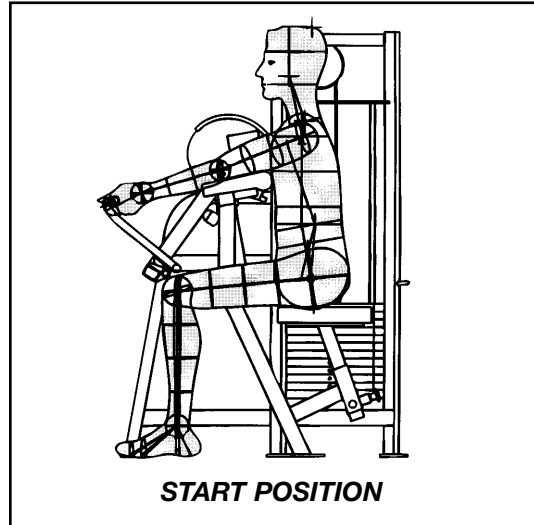

### ***The Motion***

- Tighten the biceps and flex the elbows as far as possible without raising the elbows further.
- Return to the starting position without resting and without changing the shoulder arm position or elbow alignment.